

Hall-Effect Smart Fan Motor Controller

■ Features

- On chip Hall sensor
- Rotor-locked shutdown
- Automatically restart
- Built-in Zener protection for output driver
- Operating voltage: 3.8V~20 V
- Output current: $I_{O(AVE)} = 500\text{mA}$ for SIP-4/SOT89-5
- Output current: $I_{O(AVE)} = 400\text{mA}$ for SOT23-5
- Package: SIP-4L, SOT23-5L, SOT89-5L

■ General Description

AH284 is a monolithic fan motor controller with Hall sensor's capability. It contains two complementary open-drain drivers for motor's coil driving, automatic lock shutdown and restart function relatively.

To avoid coil burning, rotor-lock shutdown detection circuit shut down the output driver if the rotor is blocked and then the automatic recovery circuit will try to restart the motor. This function repeats while rotor is blocked. Until the blocking is removed, the motor recovers running normally.

■ Pin Assignment

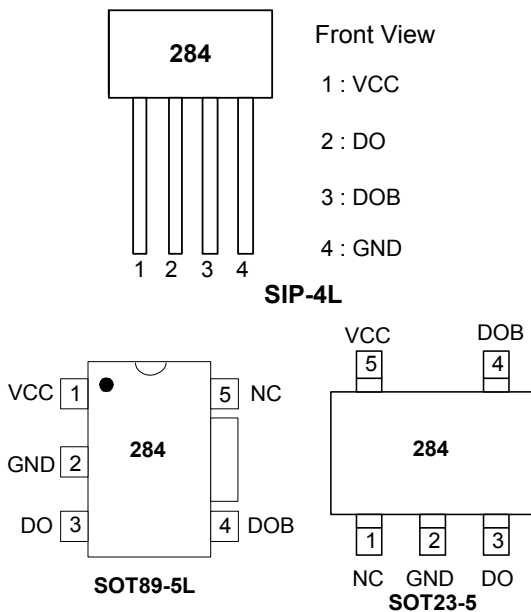

■ Pin Descriptions

Name	Description
VCC	Input power
DO	Output pin
DOB	Output pin
GND	Ground
NC	Not connected

■ Ordering Information

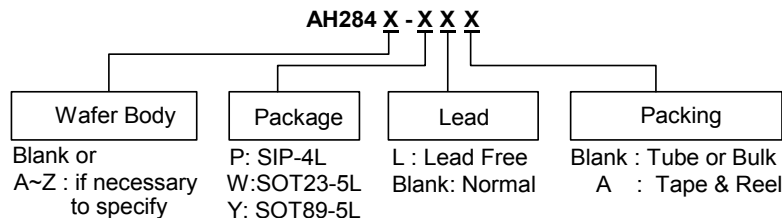

■ Block Diagram (SIP4)

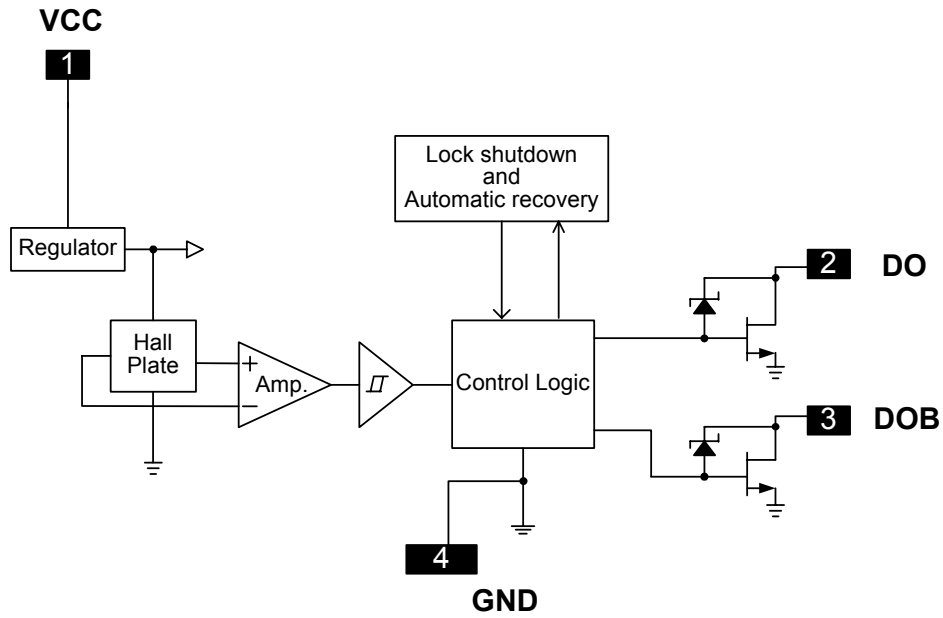

■ Typical Application Circuit (SIP4)

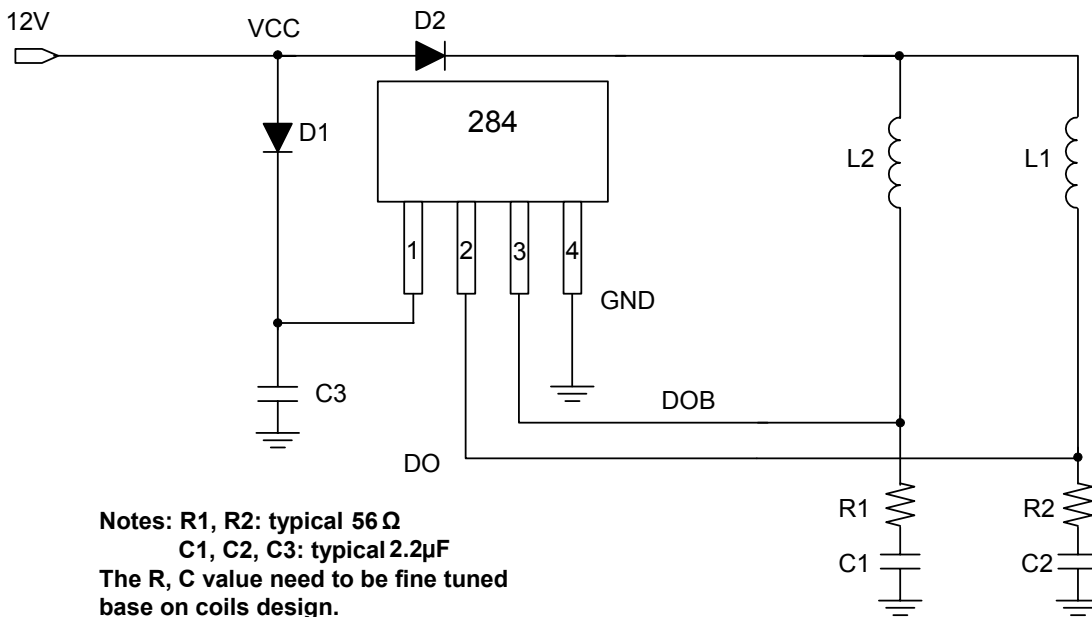

Notes: R1, R2: typical 56 Ω
 C1, C2, C3: typical 2.2 μF
 The R, C value need to be fine tuned
 base on coils design.

12V brush-less DC fan

Hall-Effect Smart Fan Motor Controller
■ Absolute Maximum Ratings (Ta = 25°C)

Characteristics	Symbol	Rating	Unit
Supply Voltage	V _{CC}	24	V
Output Current	I _{O(AVE)}	SIP4/SOT89-5	500
		SOT23-5	400
	I _{O(PEAK)}	700	
Power Dissipation	P _D	SIP4	550
		SOT23-5	230
		SOT89-5	800
Operating Temperature	T _{opr}	-40 ~ 100	°C
Storage Temperature	T _{stg}	-55 ~ 150	°C
Maximum Junction Temp.	T _J	150	°C
Thermal Resistance	θ _{Jc}	SIP4	227
		SOT23-5	543
		SOT89-5	156

■ Electrical Characteristics (Ta = 25 °C, V_{CC} = 12V, unless otherwise specified)

Characteristics	Symbol	Conditions	Min.	Typ.	Max.	Unit
Supply Voltage	V _{CC}	Operating	3.8	-	20	V
Supply current	I _{CC}	Operating	-	2.0	4.0	mA
Output Leakage Current	I _{off}	V _{OUT} =24V	-	< 0.1	10	μA
Locked Protection On	T _{lrp-on}		0.4	0.5	0.6	Sec
Locked Protection Off	T _{lrp-off}		2.4	3	3.6	Sec
Output saturation voltage	V _{OUT(sat)}	I _O =300mA	-	375	500	mV
		I _O =500mA	-	625	900	
Output On resistance	R _{ds(on)}	I _O =300mA	-	1.25	1.67	ohm
Output Zener-breakdown Voltage	V _Z		35	42	60	V

■ Magnetic Characteristics (Ta = 25 °C, V_{CC} = 12V, unless otherwise specified)

(1mT=10 Gauss)

Characteristics	Symbol	Min.	Typ.	Max.	Unit
Operate Point	B _{op}	10	30	60	Gauss
Release Point	B _{rp}	-60	-30	-10	Gauss
Hysteresis	B _{hy}	--	60	--	Gauss

■ Operating Characteristics

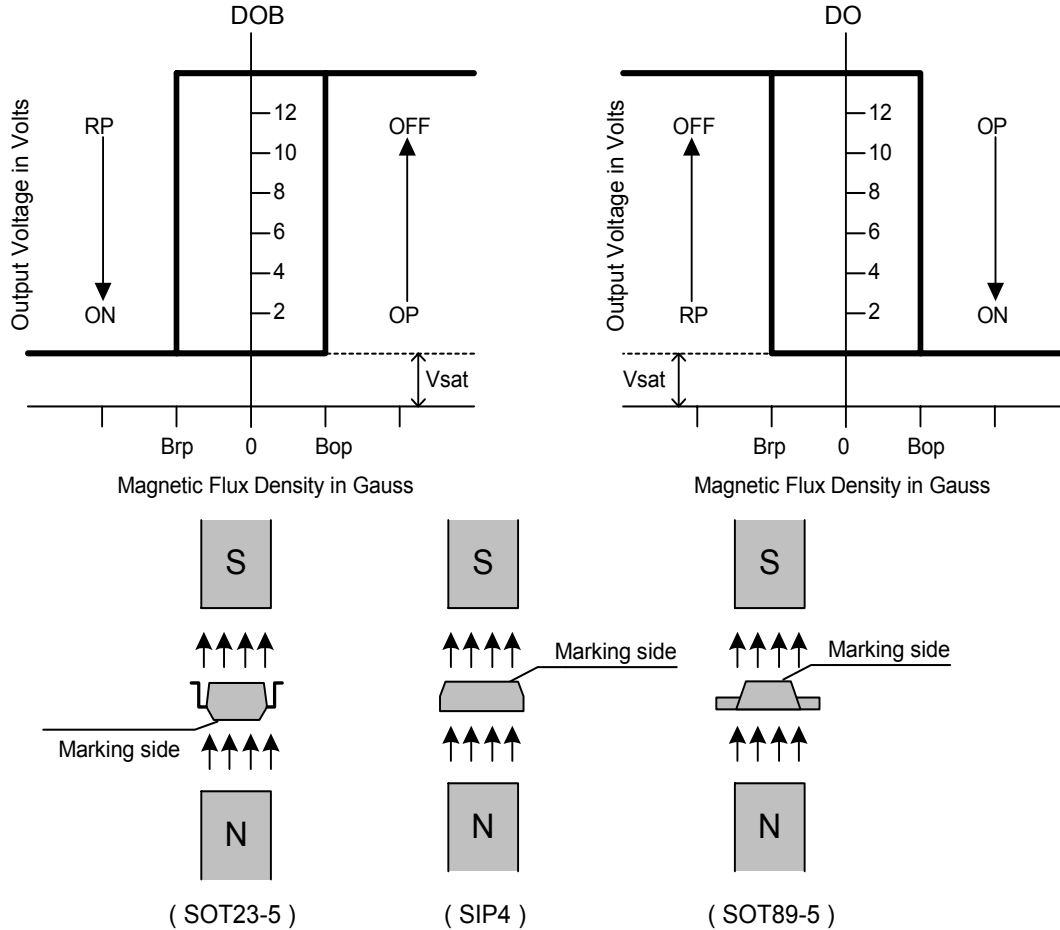

■ Performance Characteristics (SIP4)

Ta (°C)	25	50	60	70	80	85	90	95	100
Pd (mW)	550	440	396	352	308	286	264	242	220
Ta (°C)	105	110	115	120	125	130	135	140	150
Pd (mW)	198	176	154	132	110	88	66	44	0

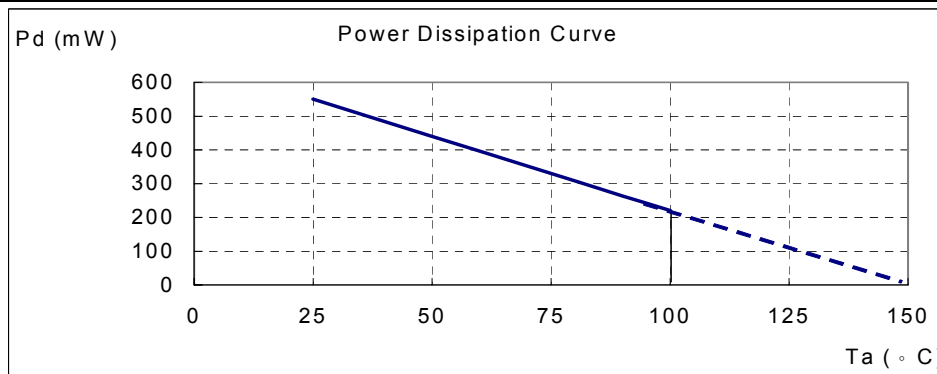

■ Performance Characteristics (SOT23-5)

Ta (°C)	25	50	60	70	80	90	100	110	120	130	140	150
Pd (mW)	230	184	166	147	129	110	92	74	55	37	18	0

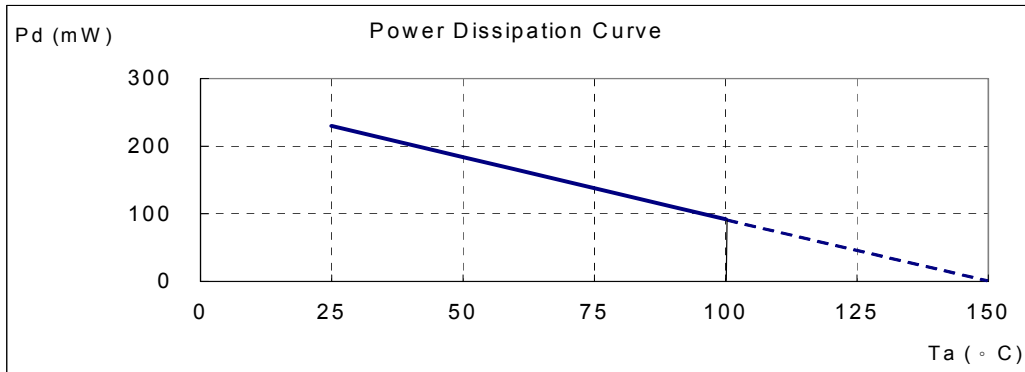

■ Performance Characteristics (SOT89-5)

Ta (°C)	25	50	60	70	75	80	85	90	95	100
Pd (mW)	800	640	576	512	480	448	416	384	352	320
Ta (°C)	105	110	115	120	125	130	135	140	145	150
Pd (mW)	288	256	224	192	160	128	96	64	32	0

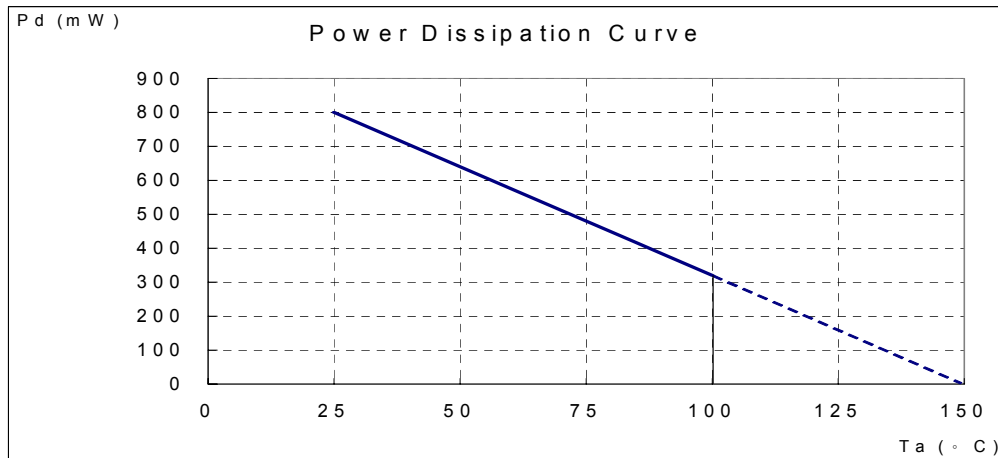

■ Marking Information

(1)SIP-4L

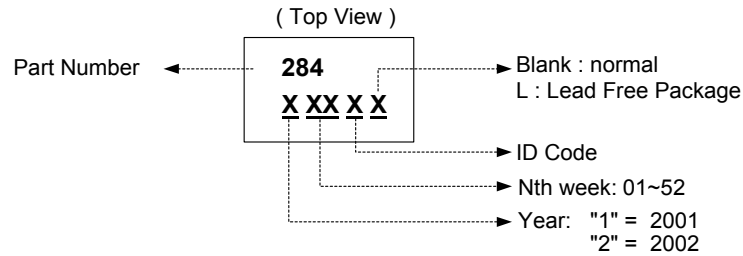

(2)SOT23-5L

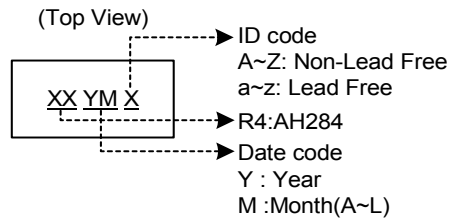

(3)SOT89-5L

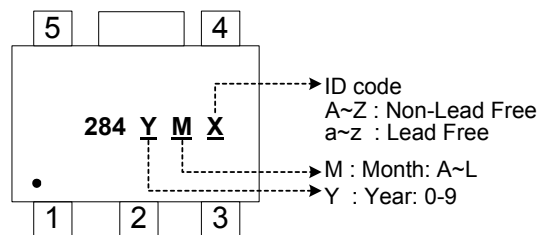

■ Package Information

(1)SIP-4L

Active Area Depth

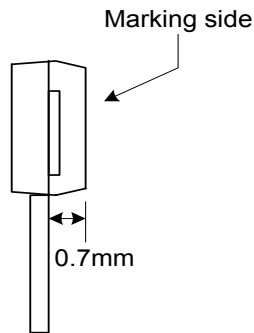

Package Sensor Location

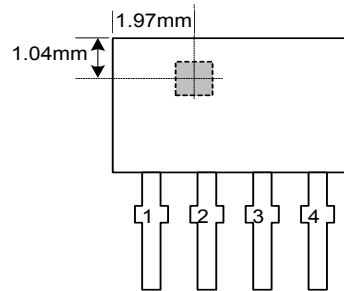

Package Dimension

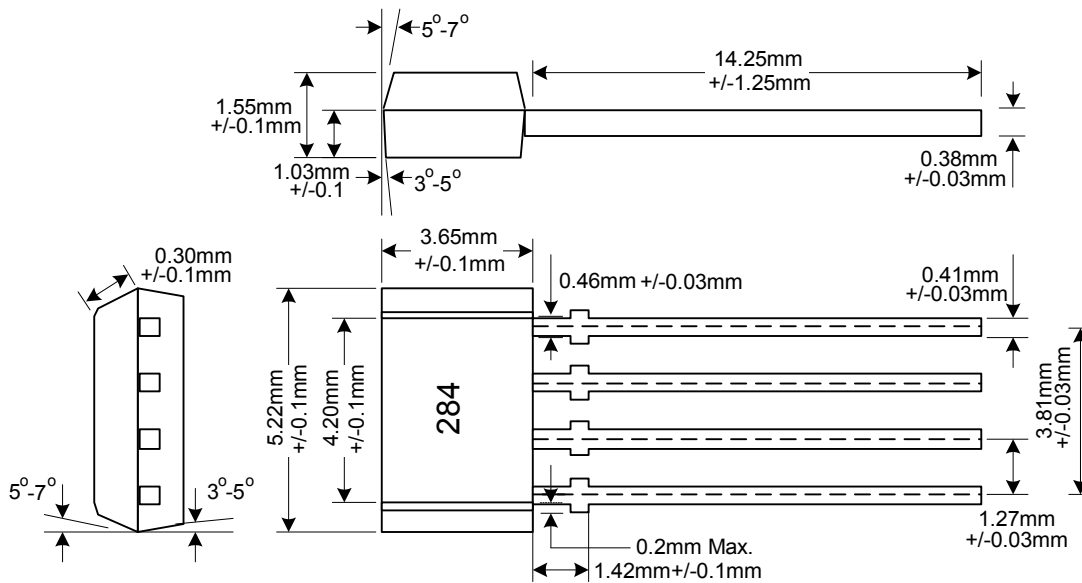

Hall-Effect Smart Fan Motor Controller

(2) SOT23-5L

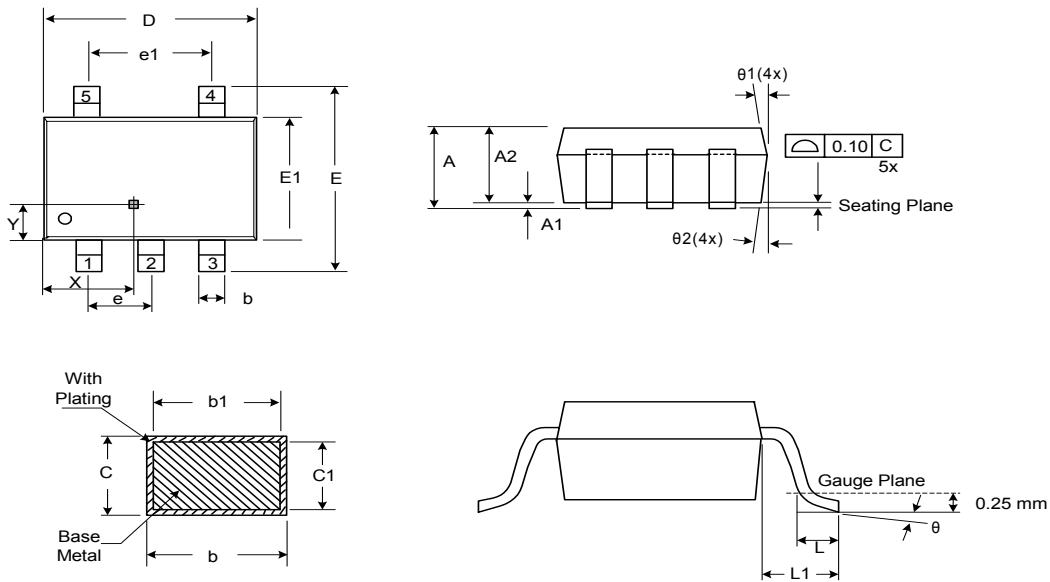

Symbol	Dimensions In Millimeters			Dimensions In Inches		
	Min.	Nom.	Max.	Min.	Nom.	Max.
A	1.05	1.20	1.35	0.041	0.047	0.053
A1	0.05	0.10	0.15	0.002	0.004	0.006
A2	1.00	1.10	1.20	0.039	0.043	0.047
b	0.25	-	0.55	0.010	-	0.022
b1	0.25	0.40	0.45	0.010	0.016	0.018
c	0.08	-	0.20	0.003	-	0.008
c1	0.08	0.11	0.15	0.003	0.004	0.006
D	2.70	2.85	3.00	0.106	0.112	0.118
E	2.60	2.80	3.00	0.102	0.110	0.118
E1	1.50	1.60	1.70	0.059	0.063	0.067
L	0.35	0.45	0.55	0.014	0.018	0.022
L1	0.60 Ref.			0.024 Ref.		
e	0.95 Bsc.			0.037 Bsc.		
e1	1.90 Bsc.			0.075 Bsc.		
θ	0°	5°	10°	0°	5°	10°
θ1	3°	5°	7°	3°	5°	7°
θ2	6°	8°	10°	6°	8°	10°
X	-	1.067	-	-	0.042	-
Y	-	0.432	-	-	0.017	-

Hall-Effect Smart Fan Motor Controller

(3) SOT89-5L

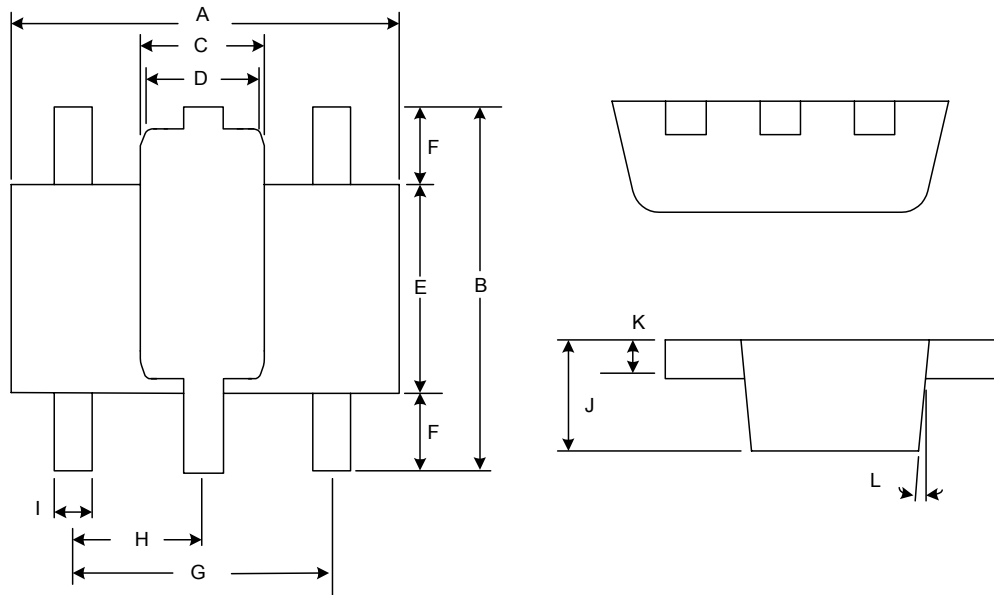

Package Sensor Location

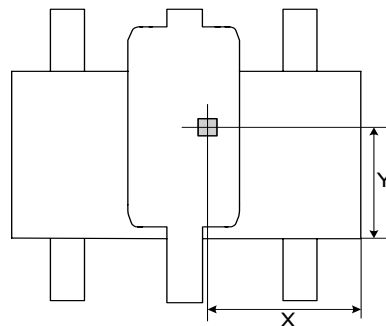

Symbol	Dimensions In Millimeters			Dimensions In Inches		
	Min.	Nom.	Max.	Min.	Nom.	Max.
A	4.40	4.50	4.60	0.173	0.177	0.181
B	4.05	4.15	4.25	0.159	0.163	0.167
C	1.50	1.60	1.70	0.059	0.063	0.067
D	1.30	1.40	1.50	0.051	0.055	0.059
E	2.40	2.50	2.60	0.094	0.098	0.102
F	0.80	-	-	0.031	-	-
G	3.00 Ref.			0.118 Ref.		
H	1.50 Ref.			0.059 Ref.		
I	0.40	0.46	0.52	0.016	0.018	0.020
J	1.40	1.50	1.60	0.055	0.059	0.063
K	0.35	0.39	0.43	0.014	0.015	0.017
L	5° Typ.			5° Typ.		
X	-	1.90	-	-	0.075	-
Y	-	1.65	-	-	0.065	-