



CYM1946

512K x 32 Static RAM Module

Features

- High-density 16-megabit SRAM module
- 32-bit Standard Footprint supports densities from 16K x 32 through 1M x 32
- High-speed SRAMs
 - Access time of 35 ns
- Low active power
 - 7.3W (max.) at 35ns
- Compatible with CYM1821, CYM1831, CYM1836, CYM1841, and CYM1851 JEDEC Modules

constructed from 16 128K x 8 SRAMs in SOJ packages mounted on an epoxy laminate substrate. Four chip selects are used to independently enable the four bytes. Reading or writing can be executed on individual bytes or any combination of multiple bytes through proper use of selects.

The CYM1946 is designed for use with standard 72-pin SIMM sockets. The pinout is downward compatible with the 64-pin JEDEC ZIP/SIMM module family (CYM1821, CYM1831, CYM1836, and CYM1841). Thus, a single motherboard design can be used to accommodate memory depth ranging from 16K words (CYM1821) to 1,024K words (CYM1851).

Presence detect pins (PD₀–PD₃) are used to identify module memory density in applications where modules with alternate word depths can be interchanged.

Functional Description

The CYM1946 is a high-performance 16-megabit static RAM module organized as 512K words by 32 bits. This module is

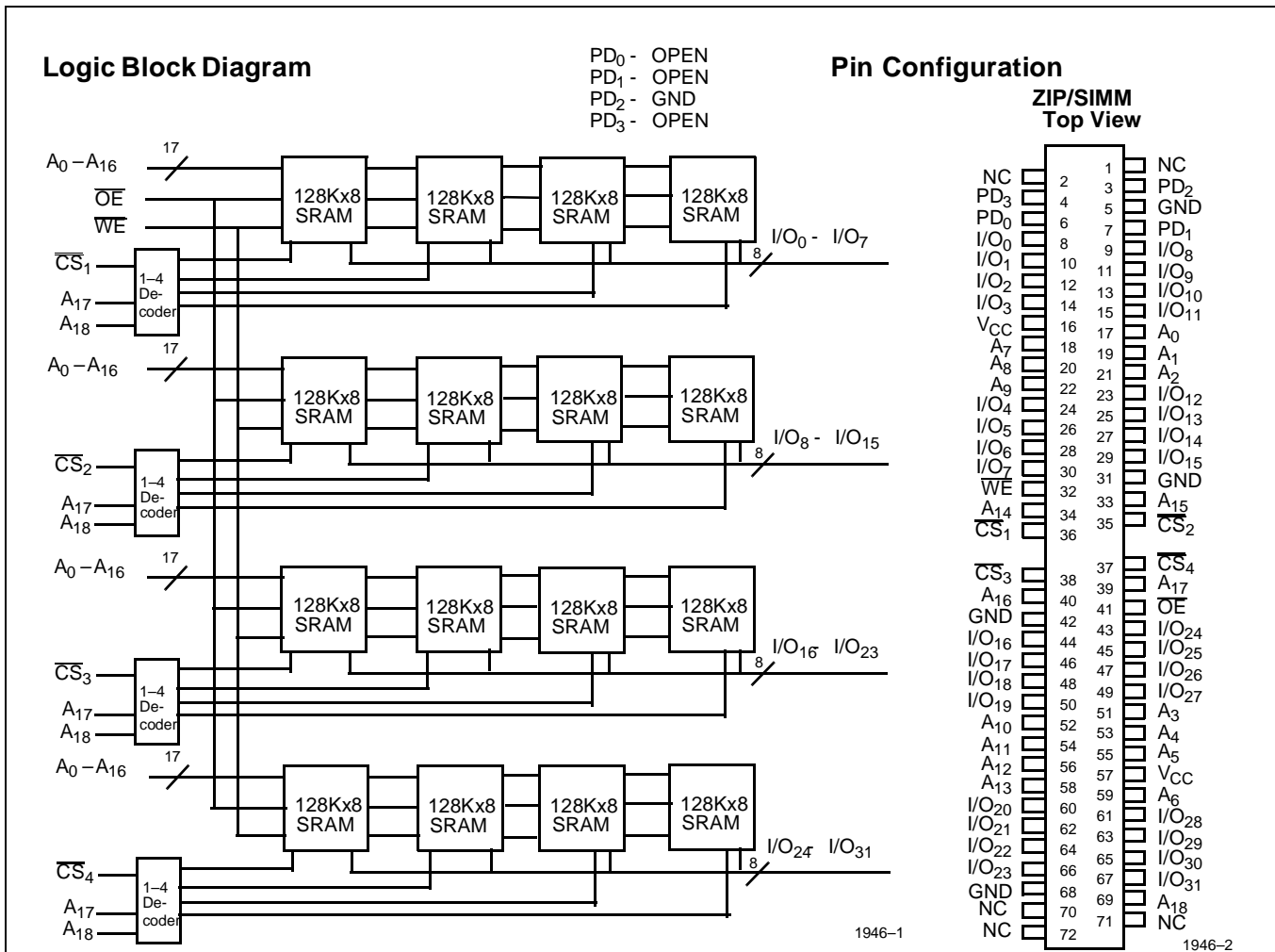

Selection Guide

	1946-35	1946-45	1946-55
Maximum Access Time (ns)	35	45	55
Maximum Operating Current (mA)	1100	1100	1100
Maximum Standby Current (mA)	585	585	585

Maximum Ratings

(Above which the useful life may be impaired. For user guidelines, not tested.)

Storage Temperature -55°C to +125°C

Ambient Temperature with Power Applied -10°C to +85°C

Supply Voltage to Ground Potential -0.5V to +7.0V

DC Voltage Applied to Outputs

in High Z State.....-0.5V to +V_{CC}

DC Input Voltage-0.5V to +7.0V

Operating Range

Range	Ambient Temperature	V _{CC}
Commercial	0°C to +70°C	5V ± 10%

Electrical Characteristics Over the Operating Range

Parameter	Description	Test Conditions	Min.	Max.	Unit
V _{OH}	Output HIGH Voltage	V _{CC} = Min., I _{OH} = -4.0 mA	2.4		V
V _{OL}	Output LOW Voltage	V _{CC} = Min., I _{OL} = 8.0 mA		0.4	V
V _{IH}	Input HIGH Voltage		2.2	V _{CC} + 0.3	V
V _{IL}	Input LOW Voltage		-0.3	0.8	V
I _{IX}	Input Load Current	GND ≤ V _I ≤ V _{CC}	-32	+32	μA
I _{OZ}	Output Leakage Current	GND ≤ V _O ≤ V _{CC} , Output Disabled	-20	+20	μA
I _{CC}	V _{CC} Operating Supply Current	V _{CC} = Max., I _{OUT} = 0 mA, CS _N ≤ V _{IL}	-35, -45, -55	1100	mA
I _{SB1}	Automatic CS Power-Down Current ^[1]	Max. V _{CC} , CS ≥ V _{IH} , Min. Duty Cycle = 100%		585	mA
I _{SB2}	Automatic CS Power-Down Current ^[1]	Max. V _{CC} , CS ≥ V _{CC} - 0.2V, V _{IN} ≥ V _{CC} - 0.2V, or V _{IN} ≤ 0.2V	-35, -45, -55	200	mA

Capacitance^[2]

Parameter	Description	Test Conditions	Max.	Unit
C _{INA}	Input Capacitance (WE, OE, A ₀₋₁₆)	T _A = 25°C, f = 1 MHz, V _{CC} = 5.0V	175	pF
C _{INB}	Input Capacitance (CS)		10	pF
C _{OUT}	Output Capacitance		45	pF
C _{INA17-18}	Input Capacitance A ₁₇₋₁₈		45	pF

Notes:

1. A pull-up resistor to V_{CC} on the CS input is required to keep the device deselected during V_{CC} power-up, otherwise I_{SB} will exceed values given.
2. Tested on a sample basis.

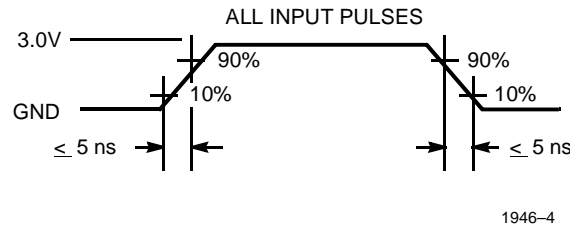
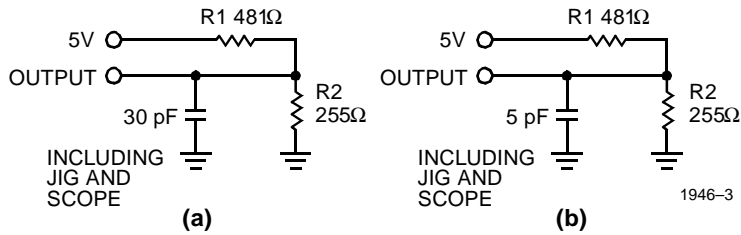
AC Test Loads and Waveforms

Equivalent to: THÉVENIN EQUIVALENT

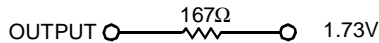
Switching Characteristics Over the Operating Range^[3]

Parameter	Description	1946-35		1946-45		1946-55		Unit
		Min.	Max.	Min.	Max.	Min.	Max.	
READ CYCLE								
t_{RC}	Read Cycle Time	35		45		55		ns
t_{AA}	Address to Data Valid		35		45		55	ns
t_{OHA}	Data Hold from Address Change	5		5		5		ns
t_{ACS}	\overline{CS} LOW to Data Valid		35		45		55	ns
t_{DOE}	\overline{OE} LOW to Data Valid		15		17		22	ns
t_{LZOE}	\overline{OE} LOW to Low Z	0		0		0		ns
t_{HZOE}	\overline{OE} HIGH to High Z		12		17		22	ns
t_{LZCS}	\overline{CS} LOW to Low Z ^[4]	10		10		10		ns
t_{HZCS}	\overline{CS} HIGH to High Z ^[4, 5]		17		22		27	ns
t_{PD}	\overline{CS} HIGH to Power-Down		35		45		55	ns
WRITE CYCLE^[6]								
t_{WC}	Write Cycle Time	35		45		55		ns
t_{SCS}	\overline{CS} LOW to Write End	30		40		50		ns
t_{AW}	Address Set-Up to Write End	30		40		50		ns
t_{HA}	Address Hold from Write End	5		5		5		ns
t_{SA}	Address Set-Up to Write Start	2		2		2		ns
t_{PWE}	\overline{WE} Pulse Width	30		35		45		ns
t_{SD}	Data Set-Up to Write End	20		25		35		ns
t_{HD}	Data Hold from Write End	7		7		7		ns
t_{LZWE}	\overline{WE} HIGH to Low Z	5		5		5		ns
t_{HZWE}	\overline{WE} LOW to High Z ^[5]		15		15		15	ns

Notes:

- Test conditions assume signal transition times of 5 ns or less, timing reference levels of 1.5V, input pulse levels of 0 to 3.0V, and output loading of the specified I_{OL}/I_{OH} and 30-pF load capacitance.
- At any given temperature and voltage condition, t_{HZCS} is less than t_{LZCS} for any given device. These parameters are guaranteed and not 100% tested.
- t_{HZCS} and t_{HZWE} are specified with $C_L = 5$ pF as in part (b) of AC Test Loads and Waveforms. Transition is measured ± 500 mV from steady-state voltage.
- The internal write time of the memory is defined by the overlap of \overline{CS} LOW and \overline{WE} LOW. Both signals must be LOW to initiate a write and either signal can terminate a write by going HIGH. The data input set-up and hold timing should be referenced to the rising edge of the signal that terminates the write.

Switching Waveforms

Read Cycle No. 1 [7,8]

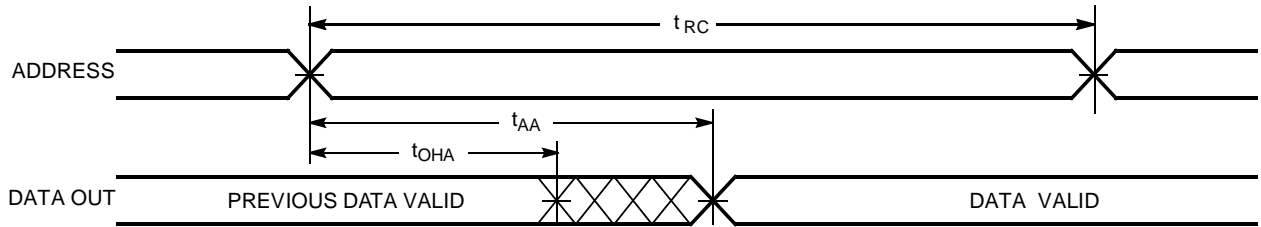

1851-5

Read Cycle No. 2 [7,9]

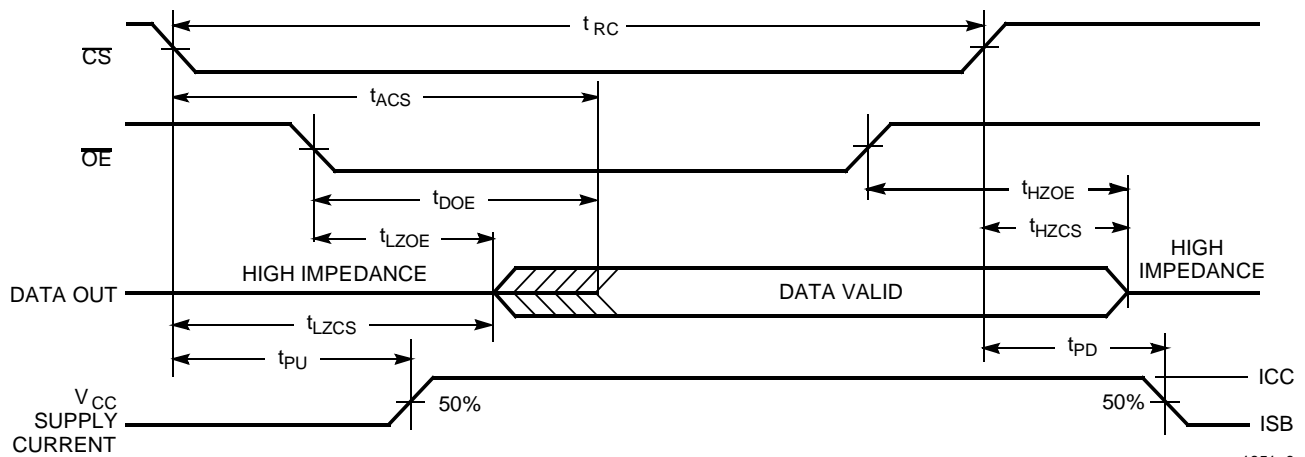

1851-6

Write Cycle No. 1 (WE Controlled) [6]

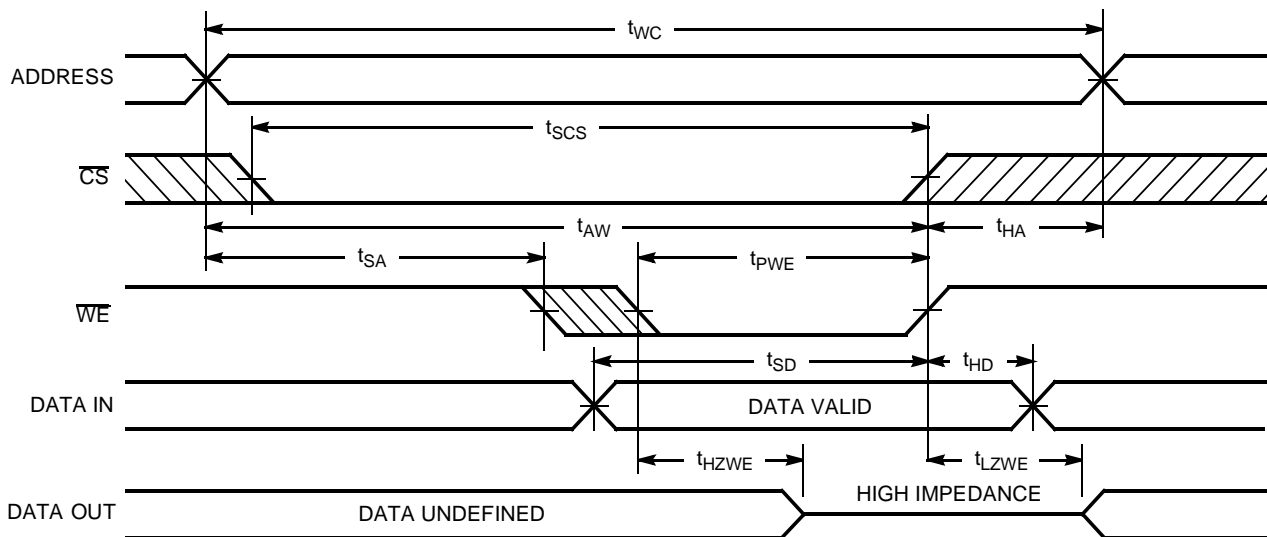

1851-7

Notes:

7. \overline{WE} is HIGH for read cycle.
8. Device is continuously selected, $\overline{CS} = V_{IL}$, and $\overline{OE} = V_{IL}$.
9. Address valid prior to or coincident with \overline{CS} transition LOW.

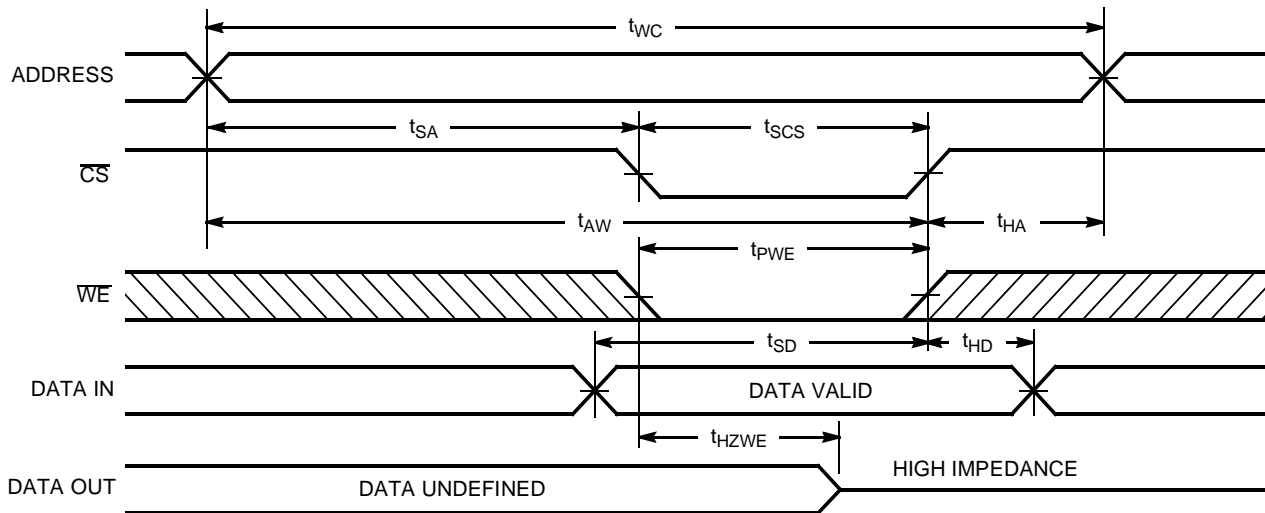
Switching Waveforms (continued)
Write Cycle No. 2 (\overline{CS} Controlled) ^[6,10]

1840-8

Note:

 10. If \overline{CS} goes HIGH simultaneously with \overline{WE} HIGH, the output remains in a high-impedance state.

Truth Table

\overline{CS}	\overline{WE}	\overline{OE}	Inputs/Output	Mode
H	X	X	High Z	Deselect/Power-Down
L	H	L	Data Out	Read
L	L	X	Data In	Write
L	H	H	High Z	Deselect

Ordering Information

Speed (ns)	Ordering Code	Package Type	Package Type	Operating Range
35	CYM1946PM-35C	PM47	72-Pin Plastic SIMM Module	Commercial
45	CYM1946PM-45C	PM47	72-Pin Plastic SIMM Module	Commercial
55	CYM1946PM-55C	PM47	72-Pin Plastic SIMM Module	Commercial

Document #: 38-M-00084

