



偉詮電子股份有限公司  
**Weltrend Semiconductor, Inc.**

---

**WT6148/WT6160**  
**Digital Monitor Controller**  
(ROM Type)

**Preliminary Data Sheet**

**REV. 1.02**

**Sep. 4, 02**

The information in this document is subject to change without notice.  
© Weltrend Semiconductor, Inc. All Rights Reserved.



### GENERAL DESCRIPTION

The WT6148/ WT6160 is a microcontroller for digital controlled monitor. It contains an 8-bit CPU, 48K /60K bytes ROM, 1056 bytes RAM, 14 PWMs, parallel I/Os, SYNC signal processor, timer, DDC1/2B interface, master/slave I<sup>2</sup>C interface, 6-bit A/D converter and watch-dog timer.

### FEATURES

- 8-bit 6502 compatible CPU with 6MHz operating frequency
- WT6148 : 48K bytes ROM,  
WT6160 : 60K bytes ROM,  
,1024 bytes SRAM+32 bytes bit addressable SRAM
- 12MHz crystal oscillator
- 14 channels 8-bit PWM outputs
- Sync signal processor with H+V separation, H/V frequency counter, H/V polarity detection/control and clamp pulse output
- Six free-running sync signal outputs (Horizontal frequency up to 106KHz 85Hz@1600x1200)
- Self-test pattern
- DDC1/2B module for EDID1.3, EDID2.0 and Enhance EDID
- Fast mode master/slave I<sup>2</sup>C interface (up to 400KHz)
- Watch-dog timer
- Maximum 28 programmable I/O pins
- One 8-bit programmable timer
- 6-bit A/D converter with 4 selectable inputs
- One external interrupt request input
- Low V<sub>DD</sub> reset

### ORDERING INFORMATION

Package Type	Part Number
42-pin PDIP	WT6148/ WT6160-N42
42-pin Shrink PDIP	WT6148/ WT6160-K42
40-pin PDIP	WT6148/ WT6160-N40
44-pin SOP	WT6148/ WT6160-S44
44-pin PLCC	WT6148/ WT6160-L44

### PIN ASSIGNMENT AND PACKAGE TYPE

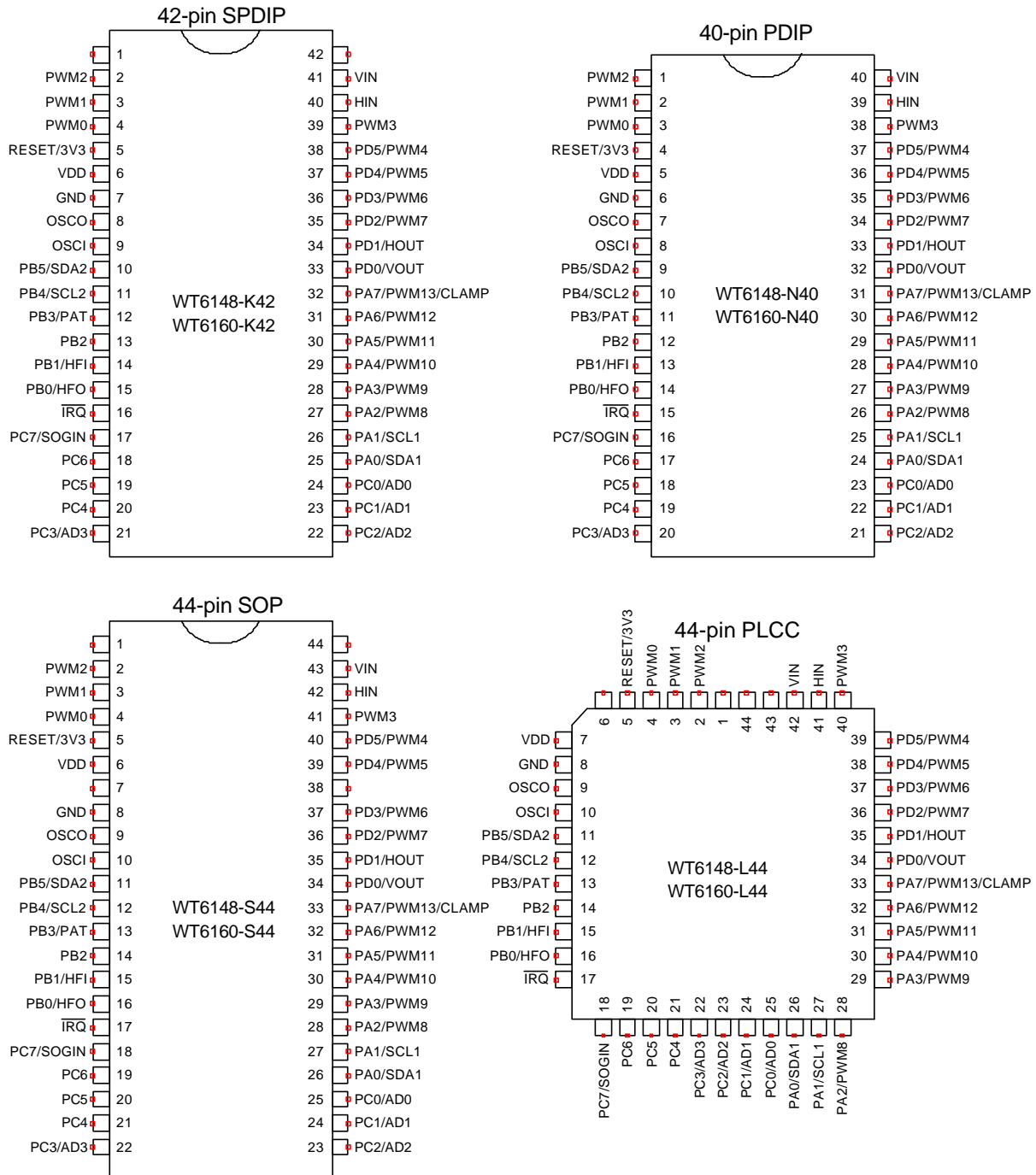



**PIN DESCRIPTION**

Pin No.				Pin Name	I/O	Description
L44	S44	42	40			
1	1	1	-	NC		No Connection.
2	2	2	1	PWM2	O	PWM2 output (10V open-drain).
3	3	3	2	PWM1	O	PWM1 output (5V open-drain).
4	4	4	3	PWM0	O	PWM0 output (5V open-drain).
5	5	5	4	/RESET	I	Reset input
6	-	-	-	NC		No Connection.
7	6	6	5	VDD		+5V power supply.
-	7	-	-	NC		No Connection.
8	8	7	6	GND		Ground.
9	9	8	7	OSCO	I/O	12MHz oscillator output.
10	10	9	8	OSCI	I	12MHz oscillator input.
11	11	10	9	PB5/ SDA2	I/O	Port B5 or I <sup>2</sup> C interface data line.
12	12	11	10	PB4/ SCL2	I/O	Port B4 or I <sup>2</sup> C interface clock line.
13	13	12	11	PB3/PAT	I/O	Port B3 or test pattern output
14	14	13	12	PB2	I/O	Port B2.
15	15	14	13	PB1/HFI	I/O	Port B1 or half frequency divider input.
16	16	15	14	PB0/HFO	I/O	Port B0 or half frequency divider output.
17	17	16	15	/IRQ	I	Interrupt request input. A low level on this can generate interrupt.
18	18	17	6	PC7/SOGIN	I/O	Port C7 or Sync on Green input.
19	19	18	17	PC6	I/O	Port C6.
20	20	19	18	PC5	I/O	Port C5.
21	21	20	19	PC4	I/O	Port C4.
22	22	21	20	PC3/AD3	I/O	Port C3 or ADC input 3.
23	23	22	21	PC2/AD2	I/O	Port C2 or ADC input 2.
24	24	23	22	PC1/AD1	I/O	Port C1 or ADC input 1.
25	25	24	23	PC0/AD0	I/O	Port C0 or ADC input 0.
26	26	25	24	PA0/SDA1	I/O	Port A0 or DDC interface SDA pin.
27	27	26	25	PA1/SCL1	I/O	Port A1 or DDC interface SCL pin.
28	28	27	26	PA2/PWM8	I/O	Port A2 or PWM8 output.
29	29	28	27	PA3/PWM9	I/O	Port A3 or PWM9 output.
30	30	29	28	PA4/PWM10	I/O	Port A4 or PWM10 output.
31	31	30	29	PA5/PWM11	I/O	Port A5 or PWM11 output.
32	32	31	30	PA6/PWM12	I/O	Port A6 or PWM12 output.
33	33	32	31	PA7/PWM13/ CLAMP	I/O	Port A7 or PWM13 output or clamp pulse output.
34	34	33	32	PD0/VOUT	I/O	Port D0 or Vsync output.
35	35	34	33	PD1/HOUT	I/O	Port D1 or Hsync output.
36	36	35	34	PD2/PWM7	I/O	Port D2 or PWM7 output.
37	37	36	35	PD3/PWM6	I/O	Port D3 or PWM6 output.
-	38	-	-	NC		No Connection.
38	39	37	36	PD4/PWM5	I/O	Port D4 or PWM5 output.
39	40	38	37	PD5/PWM4	I/O	Port D5 or PWM4 output.
40	41	39	38	PWM3	I/O	PWM3 output (10V open-drain).
41	42	40	39	HIN	I	Hsync Input.
42	43	41	40	VIN	I	Vsync input.



43	-	-	-	NC	No Connection.
44	44	42	-	NC	No Connection.

## FUNCTIONAL DESCRIPTION

### CPU

8-bit 6502 compatible CPU operates at 6MHz. Address bus is 16-bit and data bus is 8-bit. The non-maskable interrupt (/NMI) of 6502 is modified to be maskable and is defined as INT0 with higher priority. The interrupt request (/IRQ) of 6502 is defined as INT1 with lower priority.

Please refer the 6502 reference menu for more detail.

### RAM

The 1024 bytes SRAM include :  
128 bytes SRAM are from \$0080H to \$00FFH  
256 bytes SRAM are from \$0100H to \$01FFH  
256 bytes SRAM are from \$0200H to \$02FFH  
256 bytes SRAM are from \$0300H to \$03FFH  
128 bytes SRAM are from \$0400H to \$047FH

The 32 bytes SRAM bit addressible are from \$0500H to \$05FFH

### ROM

For WT6148, ROM address is located from \$4000h to \$FFFFh.  
For WT6160, ROM address is located from \$1000h to \$FFFFh.

The following addresses are reserved for special purpose :  
\$FFFAh (low byte) and \$FFFBh (high byte) : INT0 interrupt vector.  
\$FFFC h (low byte) and \$FFFDh (high byte) : program reset interrupt vector.  
\$FFFEh (low byte) and \$FFFFh (high byte) : INT1 interrupt vector.



**Memory Mapping**

WT6148		WT6160	
\$0000h	Registers	\$0000h	Registers
:		:	
\$003Fh		\$003Fh	
\$0040h	Reserved	\$0040h	Reserved
:		:	
\$007Fh		\$007Fh	
\$0080h	128 bytes RAM	\$0080h	128 bytes RAM
:		:	
\$00FFh		\$00FFh	
\$0100h	256 bytes RAM	\$0100h	256 bytes RAM
:		:	
\$01FFh		\$01FFh	
\$0200h	256 bytes RAM	\$0200h	256 bytes RAM
:		:	
\$02FFh		\$02FFh	
\$0300h	256 bytes RAM	\$0300h	256 bytes RAM
:		:	
\$03FFh		\$03FFh	
\$0400h	128 bytes RAM	\$0400h	128 bytes RAM
:		:	
\$047Fh		\$047Fh	
\$0480h	Reserved	\$0480h	Reserved
:		:	
\$04FFh		\$04FFh	
\$0500h	Bit addressible 32 bytes RAM	\$0500h	Bit addressible 32 bytes RAM
:		:	
\$05FFh		\$05FFh	
\$0600h	Reserved	\$0600h	Reserved
:		:	
\$0FFEh		\$0FFEh	
\$0FFFh	Configuration Register	\$0FFFh	Configuration Register
\$1000h	Reserved	\$1000h	ROM
:		:	
\$3FFFh		:	
\$4000h	ROM	:	
:		:	
:		:	
:		:	
:		:	
\$FFFFh		:	

### System Reset

There are four reset sources of this controller. Fig.1 shows the block diagram of reset logic.

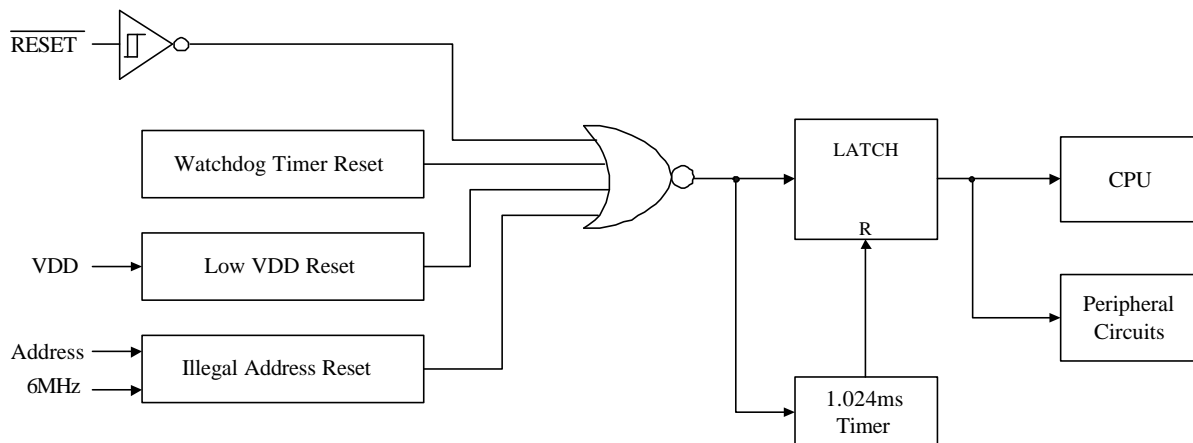

**Fig. 1 Reset Signals**

### External Reset

A low level on the RESET pin will generate reset.

### Illegal address Reset

When the address bus of CPU goes to illegal address, a reset pulse will be generated.

The illegal address is defined as \$0040h~\$007Fh and \$0600h~\$0FFEh (and \$1000h~\$3FFFh for WT6148)

### Low VDD Voltage Reset

When VDD is below 3.9V, an internal reset signal is generated. The reset signal will last 1.024 ms after the voltage is higher than 3.9V.

### Watchdog Timer Reset

If a time-out happens when watchdog timer is enabled, a reset pulse is generated. Please refer watchdog timer section for more information.

### I/O Port

#### I/O Port A

Pin PA0 and PA1 are shared with DDC interface SDA1 and SCL1. When ENDDC bit is "0", these two pins become I/O ports. If PA0OE bit is set, Pin PA0 is an **open-drain** output. If PA0OE is cleared, Pin PA0 is an input pin with **no** internal pull-up resistor. The operation of PA1 is the same as PA0. Fig. 2 shows the structure of PA0.

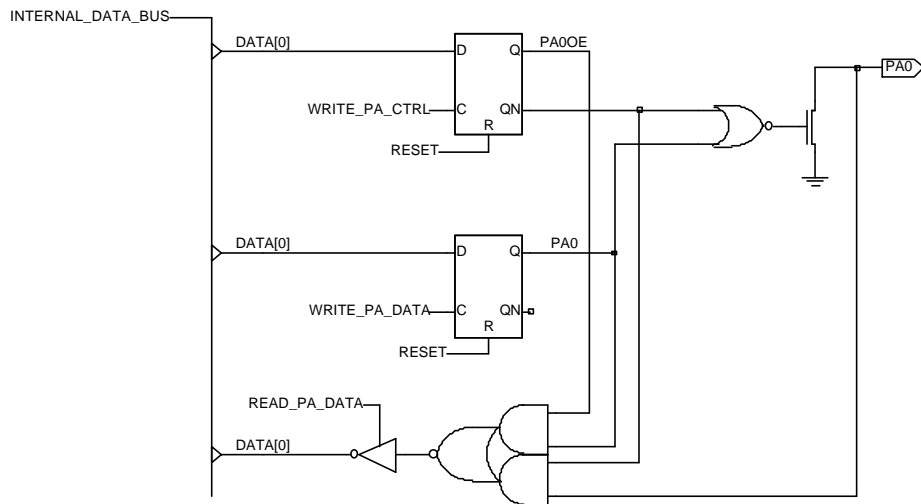

**Fig.2 Structure of PA0 and PA1**

Pin PA2 to PA6 are shared with PWM output. When the corresponding EPWMx bit is "0", the pin is an I/O port. If PAXOE bit is set, it is a push-pull type output. If PAXOE bit is cleared, it is an input pin with an internal pull-up resistor.

Pin PA7 is shared with PWM13 output and clamp pulse output. When both EPWM13 bit and ENCLP bit are "0", this pin becomes an I/O port. If PA7OE bit is set, it is a push-pull type output. If PA7OE bit is cleared, it is an input pin with an internal pull-up resistor.

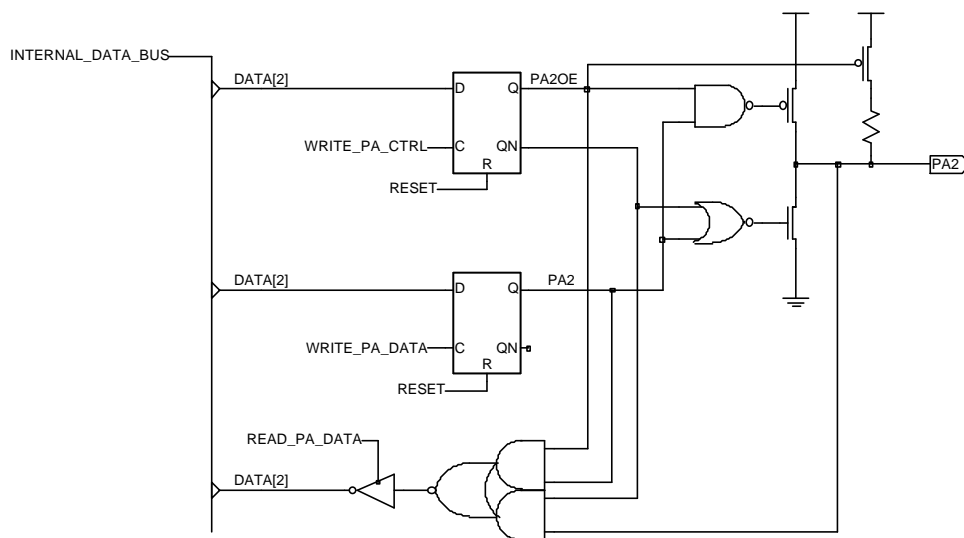

**Fig.3 Structure of PA2**





### Port A Control Register

Name	Addr	R/W	Initial	Bit 7	Bit 6	Bit 5	Bit4	Bit 3	Bit 2	Bit 1	Bit 0
PA_CTRL	0000h	W	00h	PA7OE	PA6OE	PA5OE	PA4OE	PA3OE	PA2OE	PA1OE	PA0OE

Bit Name	Description
PAnOE	Port An Output Enable. When it is set, PAn is output pin. When it is cleared, PAn is input pin with internal pull high (except PA0 and PA1 pins).

### Port A Data Register

Name	Addr	R/W	Initial	Bit 7	Bit 6	Bit 5	Bit4	Bit 3	Bit 2	Bit 1	Bit 0
PA_DATA	0001h	R	00h	PA7	PA6	PA5	PA4	PA3	PA2	PA1	PA0
		W	00h	PA7	PA6	PA5	PA4	PA3	PA2	PA1	PA0

Bit Name	Description
PAn (W)	This bit controls the output level when the corresponding PAnOE bit is set. When PAn=1, PAn pin outputs high level. (PA0 and PA1 are open-drain output) When PAn=0, PAn pin outputs low level.
PAn (R)	When PAnOE=1 (i.e. output port), this bit is same as PAn (W). When PAnOE=0, this bit indicates the input level. "1" means high and "0" means low.

### I/O Port B

I/O Port B is shared with some special functions. When the special function is disabled, it is an general I/O port and is same as Port A2. If it is configured as an output, it can source/sink 6mA. If it is configured as an input, it has an internal pull-up resistor.

### Port B Control Register

Name	Addr	R/W	Initial	Bit 7	Bit 6	Bit 5	Bit4	Bit 3	Bit 2	Bit 1	Bit 0
PB_CTRL	0002h	W	00h	--	--	PB5OE	PB4OE	PB3OE	PB2OE	PB1OE	PB0OE

Bit Name	Description
PBnOE	Port Bn Output Enable. When it is set, PBn is output pin. When it is cleared, PBn is input pin with internal pull high

### Port B Data Register

Name	Addr	R/W	Initial	Bit 7	Bit 6	Bit 5	Bit4	Bit 3	Bit 2	Bit 1	Bit 0
PB_DATA	0003h	R	00h	--	--	PB5	PB4	PB3	PB2	PB1	PB0
		W	00h	--	--	PB5	PB4	PB3	PB2	PB1	PB0

Bit Name	Description
PBn (W)	This bit controls the output level when the corresponding PBnOE bit is set. When PBn=1, PBn pin outputs high level. When PBn=0, PBn pin outputs low level.
PBn (R)	When PBnOE=1 (i.e. output port), this bit is same as PBn (W). When PBnOE=0, this bit indicates the input level. "1" means high and "0" means low.



**WT6148/WT6160***v1.02*

**Digital Monitor Controller**

---

**I/O Port C**

The structure of I/O Port C is same as Port B except the output low level has 10mA current sink capability.

**Port C Control Register**

Name	Addr	R/W	Initial	Bit 7	Bit 6	Bit 5	Bit4	Bit 3	Bit 2	Bit 1	Bit 0
PC_CTRL	0004h	W	00h	PC7OE	PC6OE	PC5OE	PC4OE	PC3OE	PC2OE	PC1OE	PC0OE

Bit Name	Description
PCnOE	Port Cn Output Enable. When it is set, PCn is output pin. When it is cleared, PCn is input pin with internal pull high

**Port C Data Register**

Name	Addr	R/W	Initial	Bit 7	Bit 6	Bit 5	Bit4	Bit 3	Bit 2	Bit 1	Bit 0
PC_DATA	0005h	R	00h	PC7	PC6	PC5	PC4	PC3	PC2	PC1	PC0
		W	00h	PC7	PC6	PC5	PC4	PC3	PC2	PC1	PC0

Bit Name	Description
PCn (W)	This bit controls the output level when the corresponding PCnOE bit is set. When PCn=1, PCn pin outputs high level. When PCn=0, PCn pin outputs low level.
PCn (R)	When PCnOE=1 (i.e. output port), this bit is same as PCn (W). When PCnOE=0, this bit indicates the input level. "1" means high and "0" means low.

**I/O Port D**

I/O Port D is shared with some special functions. When the special function is disabled, it is an general I/O port and is same as Port A2. If it is configured as an output, it can source/sink 6mA. If it is configured as an input, it has an internal pull-up resistor.

**Port D Control Register**

Name	Addr	R/W	Initial	Bit 7	Bit 6	Bit 5	Bit4	Bit 3	Bit 2	Bit 1	Bit 0
PD_CTRL	0006h	W	00h	--	--	PD5OE	PD4OE	PD3OE	PD2OE	PD1OE	PD0OE

Bit Name	Description
PDnOE	Port Dn Output Enable. When it is set, PDn is output pin. When it is cleared, PDn is input pin with internal pull high

**Port D Data Register**

Name	Addr	R/W	Initial	Bit 7	Bit 6	Bit 5	Bit4	Bit 3	Bit 2	Bit 1	Bit 0
PD_DATA	0007h	R	x0h	--	--	PD5	PD4	PD3	PD2	PD1	PD0
		W	x0h	--	--	PD5	PD4	PD3	PD2	PD1	PD0

Bit Name	Description
PDn (W)	This bit controls the output level when the corresponding PDnOE bit is set. When PDn=1, PDn pin outputs high level. When PDn=0, PDn pin outputs low level.



PDn (R)	When PDnOE=1 (i.e. output port), this bit is same as PDn (W). When PDnOE=0, this bit indicates the input level. "1" means high and "0" means low.
---------	--

## SYNC Processor

The functional block diagram of Sync Processor is shown in Fig.4. It contains H and V polarity detection circuit, H and V frequency counter, composite sync signal separation circuit, free-running H and V sync signal generator, video signal generation circuit for burn-in test and clamp pulse generator.

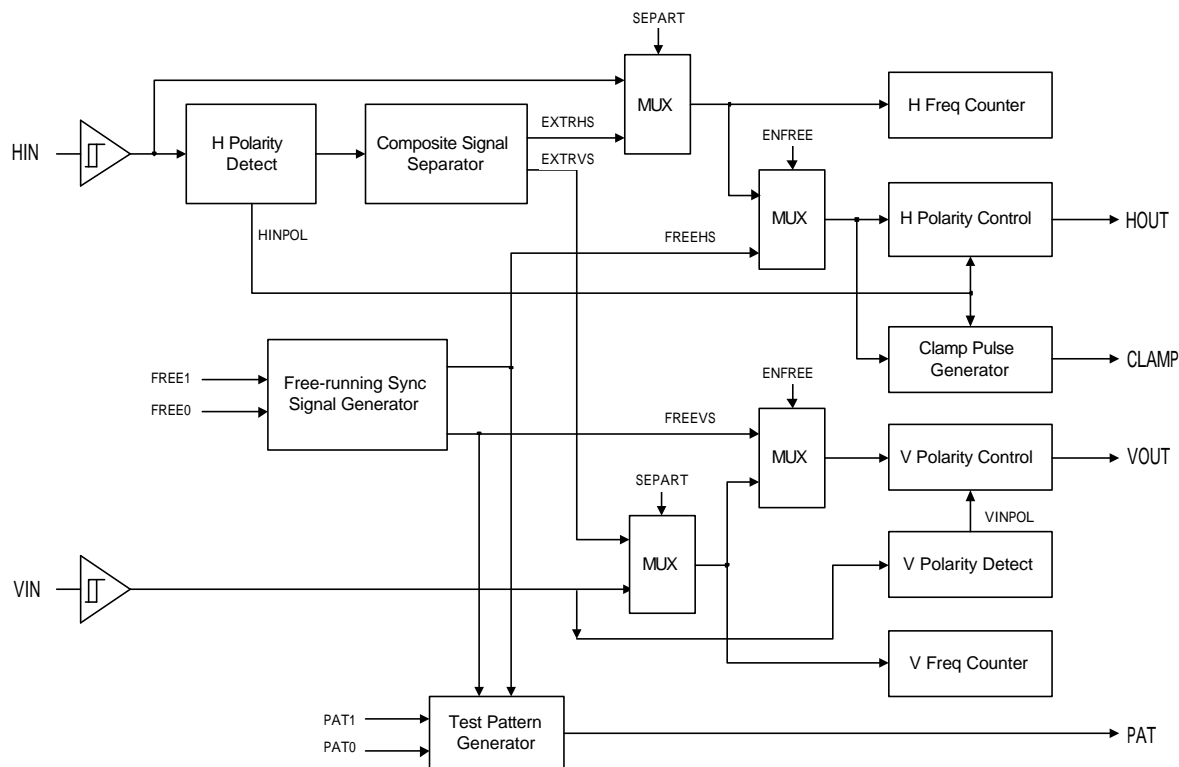

**Fig.4 Block diagram of sync signal processor**

### Horizontal Polarity Detect

The horizontal polarity is detected by sampling HIN signal at 4.5~5.5us after rising and falling edge of HIN. If the result of sampling is low and lasts 768~1024us with no change, the polarity is positive (HINPOL=1). If the result of sampling is high and lasts 768~1024us with no change, the polarity is negative (HINPOL=0).

The maximum detectable HIN frequency is 154kHz if the HIN pulse width is under 1us.

### Vertical Polarity Detect

Vertical polarity is detected by sampling VIN level at 1.024ms after rising edge of VIN. If the level is low, the polarity is positive (VINPOL=1). If the level is high, the polarity is negative (VINPOL=0). But if SEPART bit is set, the VINPOL bit is "1" because the Vsync from composite signal separator is always positive polarity.

### Output Polarity Control

The polarities of HOUT and VOUT are controlled by HOPOL and VOPOL bites. When the bit is set, the output polarity is positive. When the bit is cleared, the output polarity is negative.

### Horizontal frequency counter

A 12-bit counter is used to measure horizontal frequency. User can choose 16ms or 32ms time interval to count pulse number of Hsync every 16.384ms or 32.768ms. For example, if QUICK bit is set, when a 16.384ms time frame begins, it resets the counter and starts counting Hsync pulses till 16ms reached, then loads the counter value to HFREQ\_H and HFREQ\_L registers. If the H frequency is over 125KHz, the H counter will set overflow flag (HOVF) to "1". If the H frequency is over 187.5KHz, the H counter will stop counting. Therefore the measured H frequency is equal to 125kHz plus HFREQ\_H and HFREQ\_L

The sync processor interrupt is generated every 16.384ms or 32.768ms for checking H frequency. This interrupt will be cleared after reading the HFREQ\_H register.

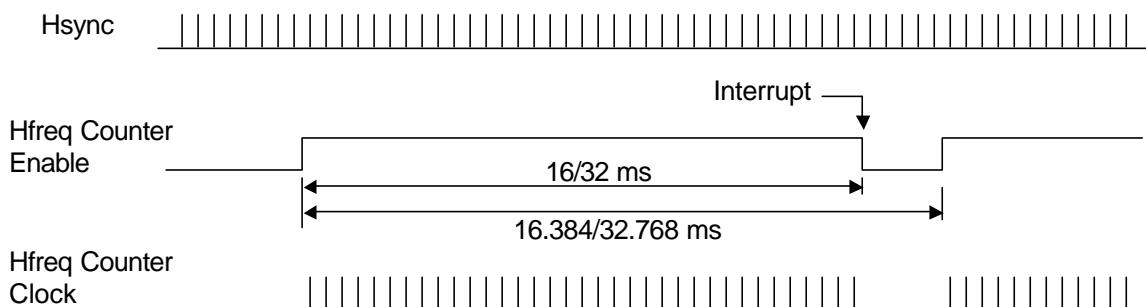

Fig.5 Horizontal Frequency Counter timing

### Horizontal Frequency Register

Name	Addr	R/W	Initial	Bit 7	Bit 6	Bit 5	Bit 4	Bit 3	Bit 2	Bit 1	Bit 0
HFREQ_L	0008h	R	xxh	HLVL	HINPOL	--	HFL4	HFL3	HFL2	HFL1	HFL0
HFREQ_H	0009h	R	xxh	HOVF	HFH6	HFH5	HFH4	HFH3	HFH2	HFH1	HFH0

Bit Name	Description
HLVL	"1" : Indicates Hsync pin is high level. "0" : Indicates Hsync pin is low level.
HINPOL	"1" : Indicates Hsync input is positive polarity. "0" : Indicates Hsync input is negative polarity.
HOVF	Indicates H counter is overflowed (over 125KHz) when this bit is set.
HFH6 ..HFH0	Indicates the Hsync frequency in kHz.
HFL4 ..HFL0	When QUICK="0", HFL4 ~ HFL0 indicates the Hsync frequency in 31.25Hz unit. When QUICK="1", HFL4 ~ HFL1 indicates the Hsync frequency in 62.5Hz.

### Example of Hsync Frequency Calculation

QUICK="0"				QUICK="1"			
HFH6..0	HFL4..0	Max. Freq	Min. Freq	HFH6..0	HFL4..0	Max. Freq	Min. Freq
\$40h	\$00000b	64.0313KHz	63.9687KHz	\$40h	\$0000xb	64.0625KHz	63.9375KHz
\$40h	\$00001b	64.0625KHz	64.0000KHz				
\$40h	\$00010b	64.0938KHz	64.0312KHz	\$40h	\$0001xb	64.1250KHz	64.0000KHz
\$40h	\$00011b	64.1250KHz	64.0625KHz				
\$51h	\$10000b	81.5313KHz	81.4687KHz	\$51h	\$1000xb	81.5625KHz	81.4375KHz
\$51h	\$10001b	81.5625KHz	81.5000KHz				
\$51h	\$10010b	81.5938KHz	81.5312KHz	\$51h	\$1001xb	81.6250KHz	81.5000KHz
\$51h	\$10011b	81.6250KHz	81.5625KHz				

**Vertical frequency counter**

A 13-bit counter is used to measure the time interval between two vertical sync pulses. It will be updated every vertical frame. The clock of this counter is 125kHz. So the frequency of Vsync is  $[125000 / (\text{counter value} \pm 1)]$  Hz. When V frequency is lower than 15.25Hz, this counter stops counting and set VOVF bit to "1".

**Vertical Frequency Register**

Name	Addr	R/W	Initial	Bit 7	Bit 6	Bit 5	Bit4	Bit 3	Bit 2	Bit 1	Bit 0
VFREQ_L	000Ah	R	xxh	VF7	VF6	VF5	VF4	VF3	VF2	VF1	VF0
VFREQ_H	000Bh	R	xxh	VLVL	VINPOL	VOVF	VF12	VF11	VF10	VF9	VF8

Bit Name	Description
VLVL	"1" : Indicates Vsync pin is high level. "0" : Indicates Vsync pin is low level.
VNPOL	"1" : Indicates Vsync input is positive polarity. "0" : Indicates Vsync input is negative polarity.
VOVF	Indicates V counter is overflowed when this is set. Vsync frequency is lower than 15.25Hz
VF12 ~ VF0	Indicates the Vertical Total Time. Vertical frequency is $[125000 / (\text{counter value} \pm 1)]$ Hz

**Example of Vsync Frequency Calculation**

VF12..0	Max. Freq	Min. Freq	VF12..0	Max. Freq	Min. Freq
\$05BDh	85.15Hz	85.034Hz	\$0783h	65.036Hz	64.969Hz
\$05BEh	85.092Hz	84.976Hz	\$0784h	65.003Hz	64.935Hz
\$05BFh	85.034Hz	84.918Hz	\$0785h	64.969Hz	64.901Hz
\$0681h	75.12Hz	75.03Hz	\$0823h	60.038Hz	59.981Hz
\$0682h	75.075Hz	74.985Hz	\$0824h	60.01Hz	59.952Hz
\$0683h	75.03Hz	74.94Hz	\$0825h	59.981Hz	59.923Hz
\$06C7h	72.088Hz	72.005Hz	\$1FFEh	15.266Hz	15.262Hz
\$06C8h	72.046Hz	71.963Hz	\$1FFEh	15.264Hz	15.260Hz
\$06C9h	72.005Hz	71.921Hz	\$1FFFh	15.262Hz	15.258Hz

**Hsync period counter**

This is an 8-bit counter that uses 6MHz clock to measure time interval between two H pulses. If the H frequency is lower than 23437.5Hz, this counter will overflow and register H\_PERD value is zero.

**Horizontal Period Register**

Name	Addr	R/W	Initial	Bit 7	Bit 6	Bit 5	Bit4	Bit 3	Bit 2	Bit 1	Bit 0
H_PERD	000Ch	R	xxh	HPRD7	HPRD6	HPRD5	HPRD4	HPRD3	HPRD2	HPRD1	HPRD0

Bit Name	Description
HPRD7 .. 0	H freq = 6MHz / (counter value+1)

**Example of Hsync Frequency Calculation**

HPRD7..0	Max. Freq	Min. Freq	HPRD7..0	Max. Freq	Min. Freq
\$49h	83.333KHz	81.081KHz	\$7Ch	48.78KHz	48KHz
\$4Ah	82.192KHz	80KHz	\$7Dh	48.387KHz	47.619KHz
\$4Bh	81.081KHz	78.947KHz	\$7Eh	48KHz	47.244KHz
\$5Dh	65.217KHz	63.83KHz	\$BFh	31.579KHz	31.25KHz
\$5Eh	64.516KHz	63.158KHz	\$C0h	31.414KHz	31.088KHz
\$5Fh	63.83KHz	62.5KHz	\$C1h	31.25KHz	30.928KHz

### Composite Sync Signal Separator

Composite sync signal separator extract Vsync signal from HIN or SOGIN input pin by filtering pulses which is less than 6us. The output Vsync signal will be widened about 4.5~5.5us. The output Hsync will be replaced by 2us pulse during Vsync pulse.

The composite sync signal separator can handle H+V and H exclusive OR V signals. Fig.5 shows the timing relationship of the extracted H and V sync signals.

If Hsync output do not want to insert pseudo H pulses (EXTRHS signal) during Vsync pulse, set BYPASS bit can let HOUT pin output waveform same as Hsync input (Note: polarity can be controlled by HOPOL bit).

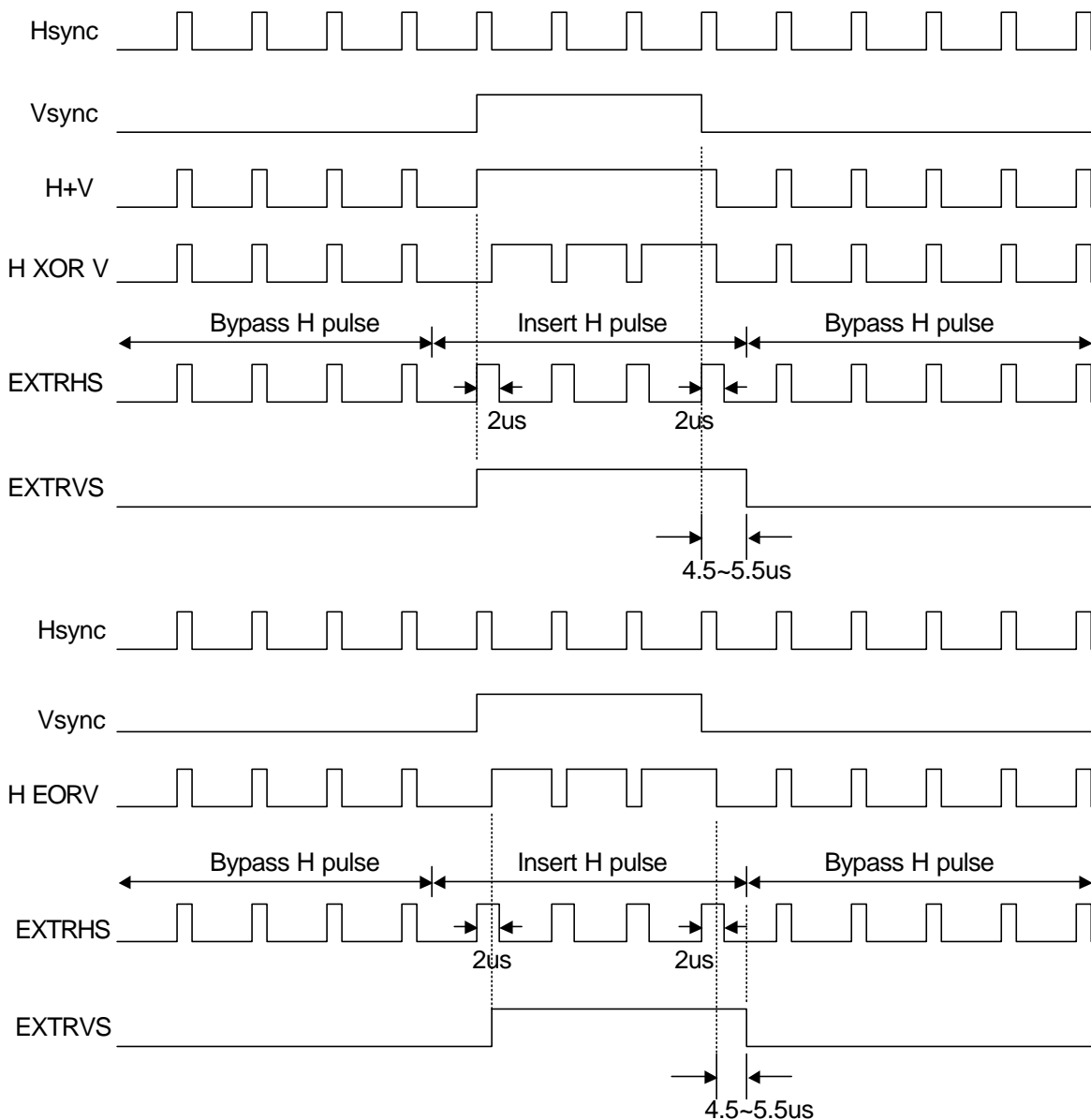

**Fig. 6 Timing relationship of composite sync signal separator**



### Free-running sync signal and self-test pattern

The self-generated free run sync signals are output from HOUT and VOUT pins when ENFREE bit is set. Four kinds of standard VESA timings are selected by FREE1 and FREE0 bits.

Self-test pattern signal is output from PAT pin when ENPAT bit is set. PAT1 and PAT0 bits select different self-test pattern.

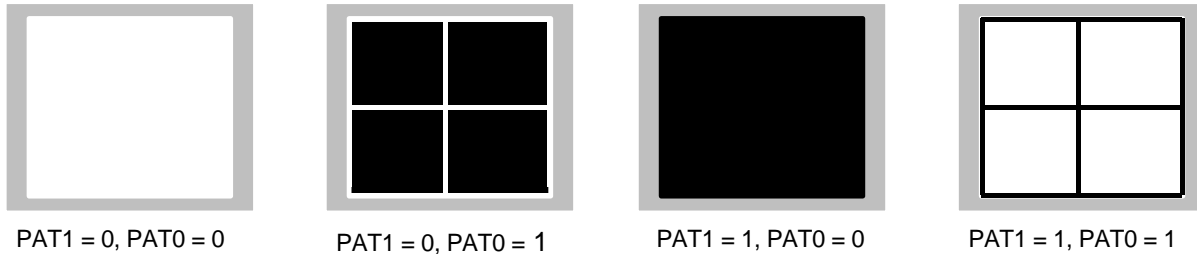

**Fig.7 Test Pattern**

FREE2,1,0 bit value		X00	X01	010	011	110	111
F <sub>H</sub>	Hor frequency	31.496KHz	48KHz	63.83KHz	81.25KHz	90.909KHz	106.195KHz
F <sub>V</sub>	Ver frequency	59.993Hz	72.072Hz	59.878Hz	64.865Hz	84.8Hz	84.96Hz
T <sub>HT</sub>	Hor total time	31.75us	20.833us	15.667us	12.333us	11us	9.417us
T <sub>VT</sub>	Ver total time	16.669ms	13.875ms	16.7ms	15.417ms	11.792ms	11.771ms
T <sub>HS</sub>	H sync time	3.833us	2.417us	1us	1.083us	1us	0.833us
T <sub>HB</sub>	H Back porch + H Left border	2 us	1.417us	2.417us	1.833us	1.583us	1.417us
T <sub>HF</sub>	H Front porch + H Right border	0.708us	1.125us	0.542us	0.375us	0.375us	0.292us
T <sub>VS</sub>	V sync time	2 x T <sub>HT</sub>	6 x T <sub>HT</sub>	3 x T <sub>HT</sub>	3 x T <sub>HT</sub>	3 x T <sub>HT</sub>	3 x T <sub>HT</sub>
T <sub>VB</sub>	V Back porch + V Top border	33 X T <sub>HT</sub>	23 x T <sub>HT</sub>	38 x T <sub>HT</sub>	46 x T <sub>HT</sub>	44 x T <sub>HT</sub>	46 x T <sub>HT</sub>
T <sub>VF</sub>	V Front porch + V Bottom border	11 x T <sub>HT</sub>	38 x T <sub>HT</sub>	3 x T <sub>HT</sub>	2 x T <sub>HT</sub>	2 x T <sub>HT</sub>	2 x T <sub>HT</sub>
T <sub>VIDEO</sub>	Video pulse width	41.67ns	41.67ns	41.67ns	41.67ns	41.67ns	41.67ns

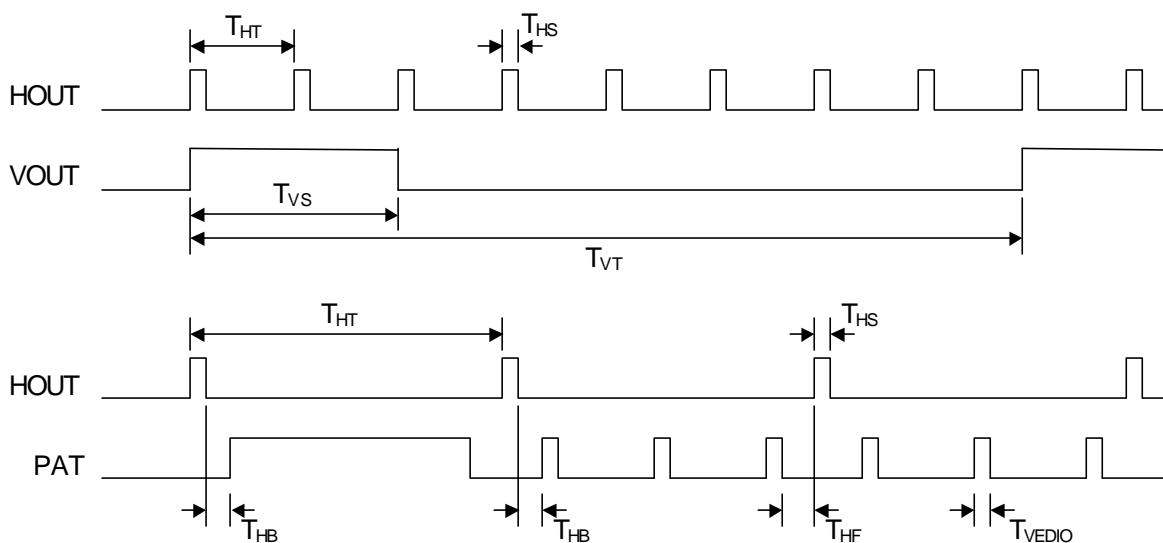

**Fig.8 Free-running sync signal and test pattern timing**

**Clamp pulse**

Clamp pulse is generated on either rising or falling edge of HOUT pin by setting the CLPEG bit. The pulse width of clamp is specified by CLPPW bit. Output polarity is specified by CLPPO bit.

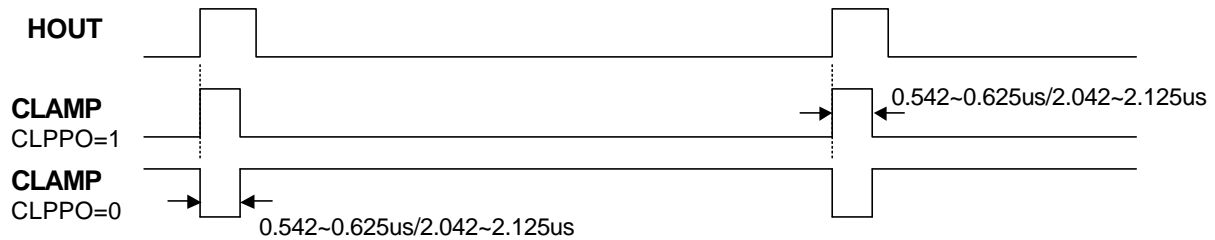
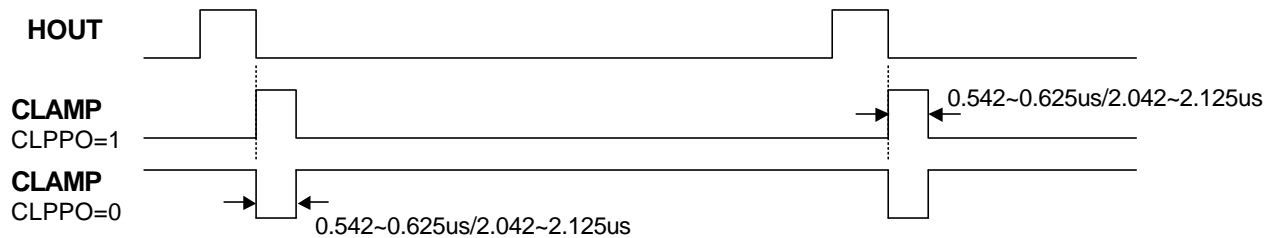
**Fig. 9a Clamp pulse waveform (CLPEG=1)**

**Fig. 9b Clamp pulse waveform (CLPEG=0)**
**Sync Processor Control Registers**

Name	Addr	R/W	Initial	Bit 7	Bit 6	Bit 5	Bit 4	Bit 3	Bit 2	Bit 1	Bit 0
HV_CR1	0008h	W	00h	ENHOUT	ENVOUT	HOPOL	VOPOL	QUICK	SEPART	ENFREE	ENPAT
HV_CR2	0009h	W	00h	ENCLP	CLPEG	CLPPO	CLPPW	FREE1	FREE0	PAT1	PAT0
HV_CR3	000Ah	W	x0h	--	--	--	--	--	SOG	FREE2	BYPASS

Bit Name	Description
ENHOUT	"1" : Enable HOUT. "0" : Disable HOUT. Pin is configured as I/O port PD1.
ENVOUT	"1" : Enable VOUT. "0" : Disable VOUT. Pin is configured as I/O port PD0.
HOPOL	"1" : HOUT is positive polarity. "0" : HOUT is negative polarity.
VOPOL	"1" : VOUT is positive polarity. "0" : VOUT is negative polarity.
QUICK	"1" : Select 16ms time interval to count H pulses every 16.384ms. "0" : Select 32ms time interval to count H pulses every 32.768ms.
SEPART	"1" : Enable sync separator circuit and use the extracted Vsync signal as VOUT. "0" : VOUT pin outputs Vsync from VIN pin
ENFREE	Enable free-running sync signal output on HOUT and VOUT pins when this bit is set.
ENPAT	"1" : Enable self-test pattern output on PAT pin when this bit is set. "0" : Disable test pattern output. Pin is configured as I/O port PB3.
ENCLP	"1" : Enable clamp pulse output on CLAMP pin. "0" : Disable clamp pulse output. Pin is configured as I/O port PA7.



CLPEG	<p>“1” : Clamp pulse follows HOUT signal' s rising edge.          “0” : Clamp pulse follows HOUT signal' s falling edge.</p>
CLPPO	<p>Select polarity of clamp pulse.          “1” : Positive polarity          “0” : Negative polarity</p>
CLPPW	<p>Select pulse width of clamp pulse.          “1” : 2us          “0” : 0.5us</p>
FREE2,1,0	<p>Select free-running sync signal frequency.          “111” : 1600x1200@85Hz                    H = 106.25kHz, V = 85Hz          “110” : 1280x1024@85Hz                    H = 91kHz, V = 85Hz          “011” : 1600x1200@65Hz                    H = 81kHz, V = 65Hz          “010” : 1280x1024@60Hz                    H = 64kHz, V = 60Hz          “x01” : 800x600@72Hz                    H = 48kHz, V = 72Hz          “x00” : 640x480@60Hz                    H = 31.4kHz, V = 60Hz</p>
PAT1,0	<p>Select test pattern.          “00” : White picture          “01” : 2x2 cross hatch          “10” : Black picture          “11” : Inverse 2x2 cross hatch</p>
SOG	<p>Select composite sync signal input source.          “1” : Composite sync signal comes from SOGIN pin.          “0” : Composite sync signal comes from HIN pin.</p>
BYPASS	<p>Select bypass the composite signal separator or not.          “1” : HOUT pin outputs sync signal bypass the composite signal separator.          “0” : HOUT pin outputs sync signal from the composite signal separator.</p>

### Half Frequency Function

When ENHLFIO bit is set, Pin PB1 becomes half frequency input (HLFI) and Pin PB0 becomes half frequency output (HLFO). The HALF bit controls the divided-by-two function is enabled or not.

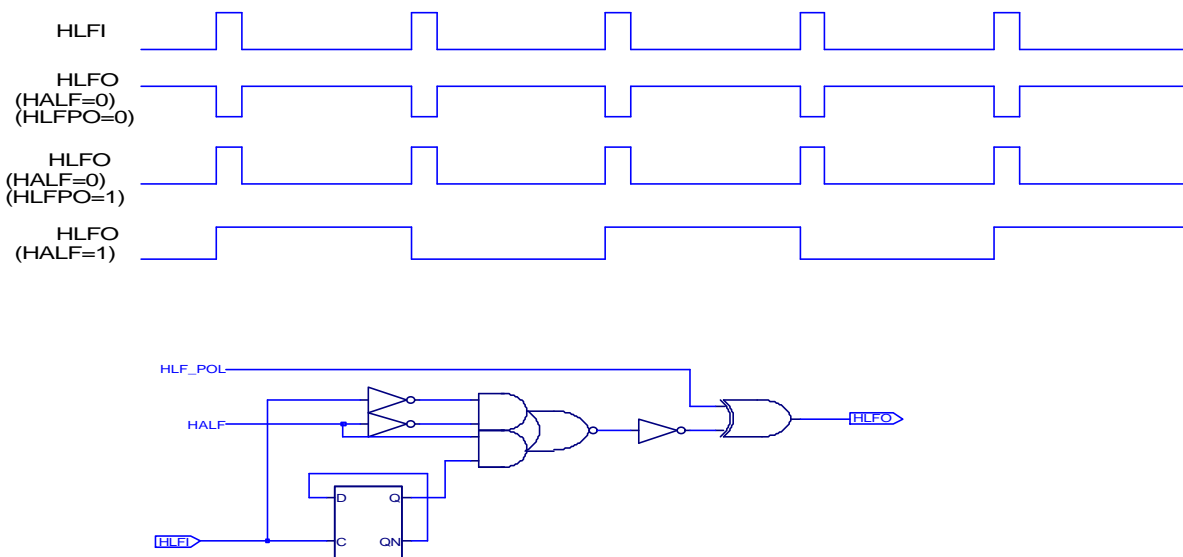

Fig. 10 Half Hsync frequency

### Half Frequency Output Control Register

Name	Addr	R/W	Initial	Bit 7	Bit 6	Bit 5	Bit 4	Bit 3	Bit 2	Bit 1	Bit 0
HLF_CON	000Dh	W	x0h	--	--	--	--	--	ENHLFIO	HALF	HF_POL

Bit Name	Bit Description
ENHLFIO	Enable half frequency input and output pins. "1" : PB1 and PB0 pins are half frequency input and output pins. "0" : PB1 and PB0 pins are I/O port.
HALF	"1" : HLFO pin outputs half frequency from HLF_I pin. "0" : HLFO pin outputs same frequency from HLF_I pin.
HF_POL	"1" : HLFO polarity is same as HLF_I. "0" : HLFO polarity is not same as HLF_I.

### DDC Interface

The DDC interface is a slave mode I<sup>2</sup>C interface with DDC1 function. It is compatible with VESA DDC1/2B standard. This interface not only can be used for DDC communication, but also can be applied for factory alignment purpose.

When ENDDC bit is set, the outputs of SDA1 and SCL1 pins are open-drain type. The DDC function depends on the DDC2 bit value. If DDC2 bit is "0", it is in DDC1 state. If DDC2 bit is "1", it is in DDC2 state

In DDC1 state, the data is shifted out to SDA1 pin on the rising edge of VSYNC clock. Data format is an 8-bit byte followed by a null bit (always "1"). Most significant bit (MSB) is transmitted first. Every time when the ninth bit has been transmitted, the shift register will load a data byte from data buffer (DDC\_TX register). After loading data to the shift register, the data buffer becomes empty and generates an interrupt. Program can check DDCRDY bit to load new data byte.

If a high to low transition occurs on SCL1 in DDC1 state, the SCLH2L bit will be set and generate an interrupt. Program can set DDC2 bit to enter DDC2 state. If no valid DDC2 command is received within a certain time (for example, 128 Vsync clocks or 2sec), program should clear DDC2 bit and back to DDC1 state to avoid noise interference.

The data format of DDC2 is

S	Address	R/W	A	D7,D6,...., D0	A		D7,D6,...., D0	A	P
---	---------	-----	---	----------------	---	--	----------------	---	---

S : Start condition. A falling edge on SDA1 pin when SCL1 pin is high level.

P : Stop condition. A rising edge on SDA1 pin when SCL1 pin is high level.

A : Acknowledge bit. "0" means acknowledge and "1" means non-acknowledge.

Address : 7-bit device address.

R/W : Read/Write control bit, "1" is read and "0" is write.

D7,D6,...., D0 : data byte.

In DDC2 state, after START and valid address is received, it send out ACK("0") if the TXNAK1 bit is "0". Otherwise the SDA1 pin outputs NACK("1"). An interrupt will be generated after sending ACK bit and SCL1 pin is pulled low to stop the clock for handshaking. In the interrupt routine, write DDC\_AR0 register will stop pulling low the SCL1 pin and clear the interrupt. The received address byte can be read in DDC\_RX register and also can use MATCH bit to identify what address is received. The Write or Read operation can be checked by reading the DDCRW bit.

#### Write operation

After received the first byte (address byte), interrupt routine finds it is the first byte (FIRST=1) and write operation (DDCRW=0), program should clear TX bit to "0" (for receiving data) and write DDC\_AR0 register (to release the SCL1 pin). Then the host sends out a data byte and SDA1 pin outputs ACK if TXNACK bit is "0". An interrupt is generated after the ACK bit to inform CPU to read DDC\_RX register. When host finished transferring data, it will send STOP condition. When STOP condition is detected, the STOP bit will be set and generates an interrupt. The interrupt routine can use the STOP bit to know the data transfer is finished and start executing the received command.

#### Read operation

After received the first byte (address byte), interrupt routine finds it is the first byte (FIRST=1) and read operation (DDCRW=1), program should set TX bit to "1", write data to DDC\_TX register and write DDC\_AR0 register (to release the SCL1 pin). The host will output ACK after received a data byte. When host wants to finish reading, it outputs NACK to stop communication. Program can read the RXACK1 bit to check the acknowledge bit that host sends.

### DDC1 Timing

#### (1) DDC1 transmit :

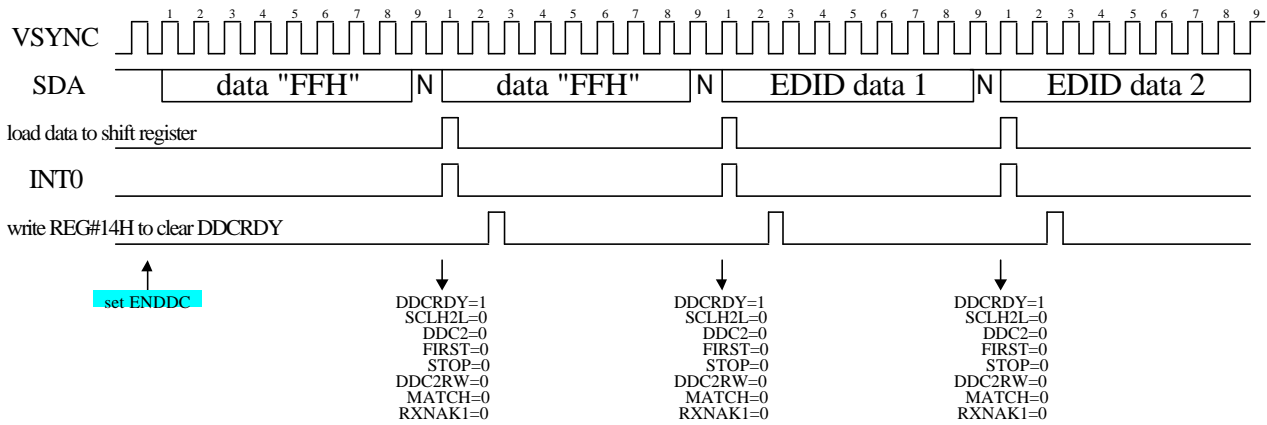

#### (2) DDC1 to DDC2 transition (I) :

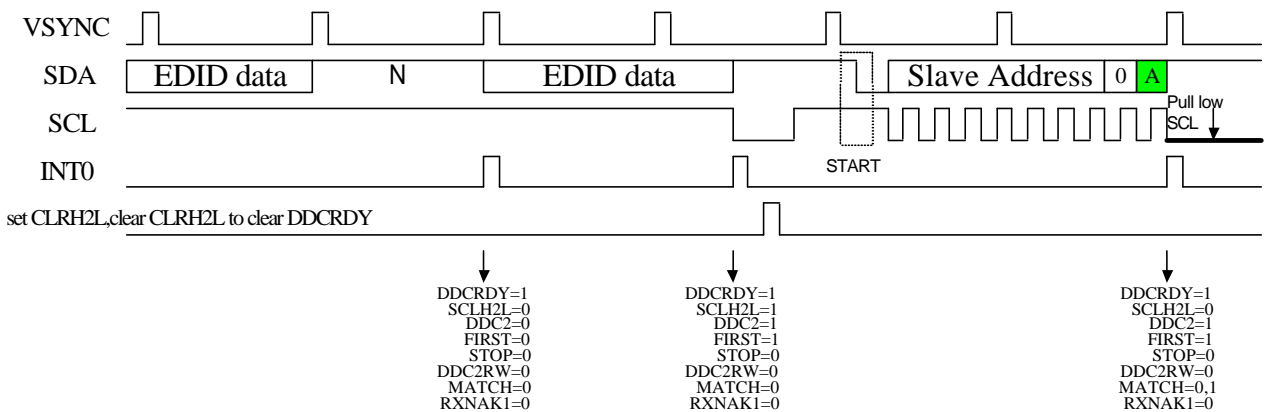

#### (3) DDC1 to DDC2 transition (II) :

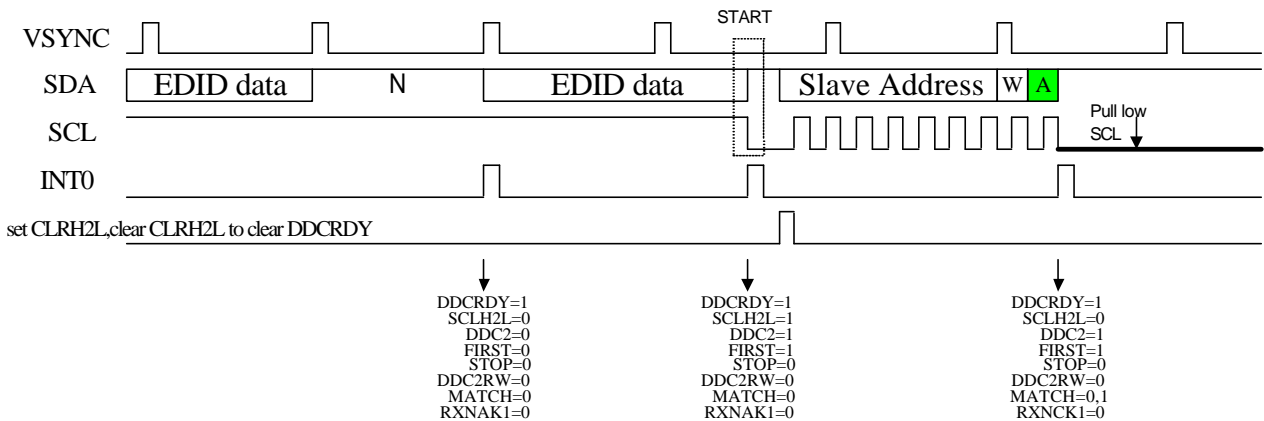

### DDC2 Timing

#### (1) Write mode :

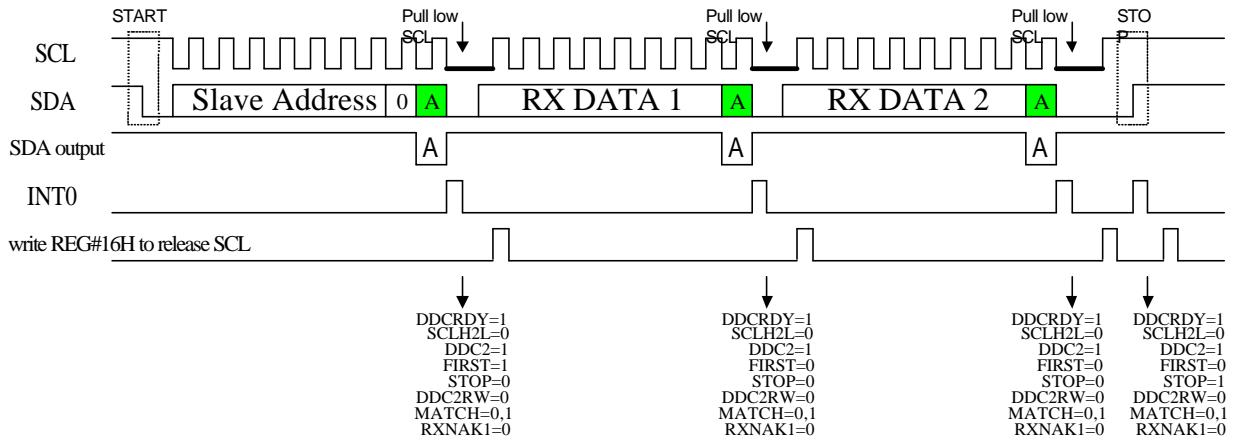

#### (2) Read mode (I) :

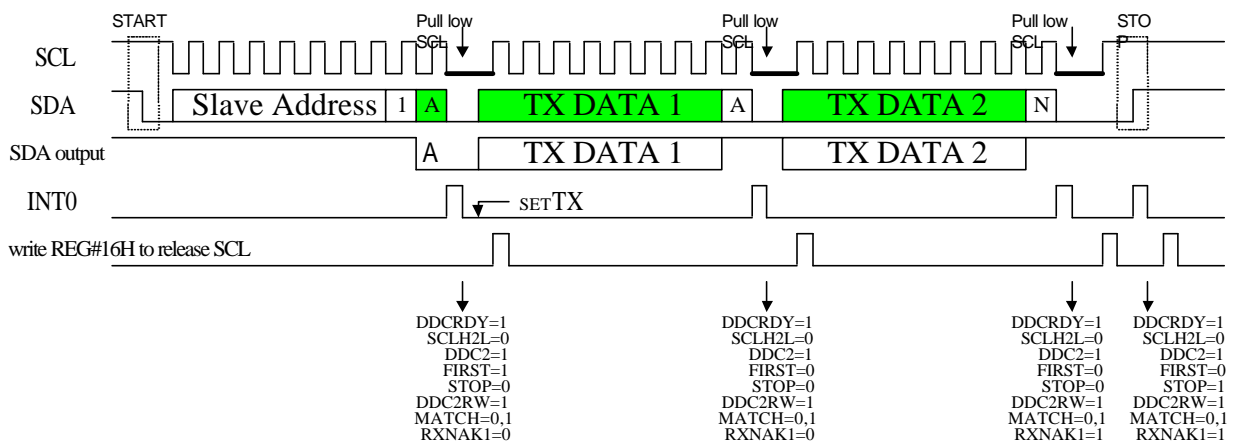

#### (3) Read mode (II) :

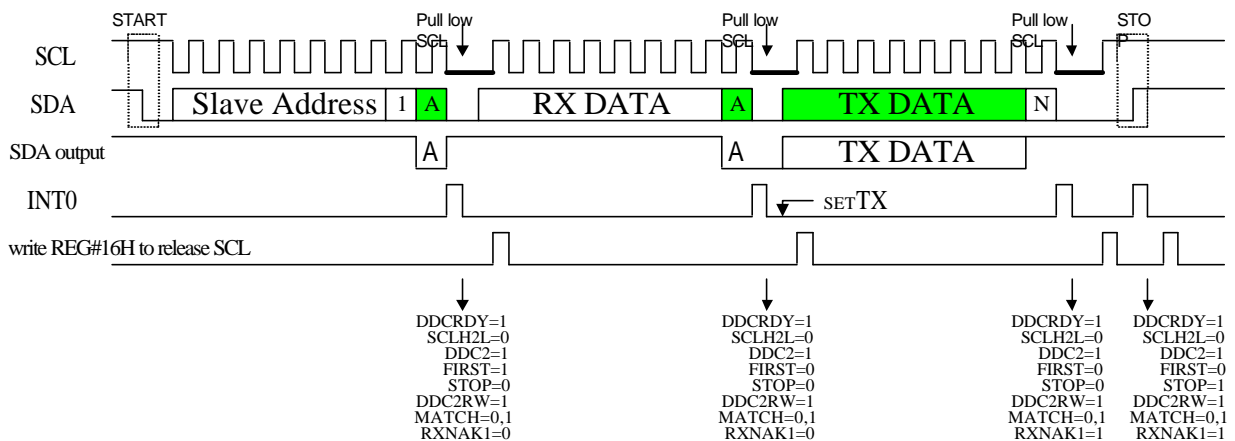



**DDC Address 0 Enable Register**

Name	Addr	R/W	Initial	Bit 7	Bit 6	Bit 5	Bit4	Bit 3	Bit 2	Bit 1	Bit 0
DDC_A0E	0013h	W	FFh	ENADR07	ENADR06	ENADR05	ENADR04	ENADR03	ENADR02	ENADR01	ENADR00

Bit Name	Description
ENADR07	Enable (DAR07~ DAR04 +“111xB”) address to be compared when it is set.
ENADR06	Enable (DAR07~ DAR04 +“110xB”) address to be compared when it is set.
ENADR05	Enable (DAR07~ DAR04 +“101xB”) address to be compared when it is set.
ENADR04	Enable (DAR07~ DAR04 +“100xB”) address to be compared when it is set.
ENADR03	Enable (DAR07~ DAR04 +“011xB”) address to be compared when it is set.
ENADR02	Enable (DAR07~ DAR04 +“010xB”) address to be compared when it is set.
ENADR01	Enable (DAR07~ DAR04 +“001xB”) address to be compared when it is set.
ENADR00	Enable (DAR07~ DAR04 +“000xB”) address to be compared when it is set.

**DDC Receive Buffer Register**

Name	Addr	R/W	Initial	Bit 7	Bit 6	Bit 5	Bit4	Bit 3	Bit 2	Bit 1	Bit 0
DDC_RX	0014h	R	FFh	DRX7	DRX6	DRX5	DRX4	DRX3	DRX2	DRX1	DRX0

Bit Name	Description
DRX7 ..DRX0	DDC received data is stored in this register.

**DDC Transmit Buffer Register**

Name	Addr	R/W	Initial	Bit 7	Bit 6	Bit 5	Bit4	Bit 3	Bit 2	Bit 1	Bit 0
DDC_TX	0014h	W	FFh	DTX7	DTX6	DTX5	DTX4	DTX3	DTX2	DTX1	DTX0

Bit Name	Description
DTX7 ..DTX0	This register stores the data to be transmitted

**DDC Status Register**

Name	Addr	R/W	Initial	Bit 7	Bit 6	Bit 5	Bit4	Bit 3	Bit 2	Bit 1	Bit 0
DDC_STA	0015h	R	01h	DDCRDY	SCLH2L	DDC2	FIRST	STOP	DDC2RW	MATCH	RXNAK1

Bit Name	Description
DDCRDY	When it is set, data buffer is ready to read/write or a SCL1 high to low transition in DDC1 state.
SCLH2L	Indicates a high to low transition on SCL1 pin in DDC1 state when it is set.
DDC2(R)	“1” : Indicates it is in DDC2 state. “0” : Indicates it is in DDC1 state.
FIRST	Indicates the first byte (address) is received when this bit is set.
STOP	Indicates STOP condition is received when this bit is set.
DDC2RW	Indicates the received R/W bit after 7-bit address. “1” : Read “0” : Write
MATCH	“1” : Address is equal to Address Register 1 or Address Register 2. “0” : The most significant 4 bits are equal to Address Register 0.
RXNAK1	Indicates the received acknowledge bit. “1” : NACK “0” : ACK





### DDC Control Register

Name	Addr	R/W	Initial	Bit 7	Bit 6	Bit 5	Bit 4	Bit 3	Bit 2	Bit 1	Bit 0
DDC_CON	0015h	W	00h	ENDDC	CLR2L	DDC2	--	--	TX	--	TXNAK1

Bit Name	Description
ENDDC	"1" : Enable DDC interface. PA0 and PA1 are configured as DDC interface. "0" : Disable DDC interface. PA0 and PA1 are configured as I/O port.
CLR2L	Set this bit will reset SCL2L bit.
DDC2(W)	"1" : Set DDC2. "0" : Set DDC1.
TX	"1" : Set transmit direction. "0" : Set receive direction.
TXNAK1	Determines the ACK bit to be transmitted. "1" : Transmit NACK. "0" : Transmit ACK.

### DDC Address Register 0

Name	Addr	R/W	Initial	Bit 7	Bit 6	Bit 5	Bit 4	Bit 3	Bit 2	Bit 1	Bit 0
DDC_AR0	0016h	W	X0h	DAR07	DAR06	DAR05	DAR04	--	--	--	ENAR0

Bit Name	Description
DAR07~ DAR04	4-bit DDC address to be compared. DAR07 is compared with the MSB of the received address.
ENAR0	Enable DAR07- DAR04 to be compared when this bit is set.

### DDC Address Register 1

Name	Addr	R/W	Initial	Bit 7	Bit 6	Bit 5	Bit 4	Bit 3	Bit 2	Bit 1	Bit 0
DDC_AR1	0017h	W	X0h	DAR17	DAR16	DAR15	DAR14	DAR13	DAR12	DAR11	ENAR1

Bit Name	Description
DAR17~ DAR11	7-bit DDC address to be compared. DAR17 is compared with the MSB of the received address.
ENAR1	Enable DAR17- DAR11 to be compared when this bit is set.

### DDC Address Register 2

Name	Addr	R/W	Initial	Bit 7	Bit 6	Bit 5	Bit 4	Bit 3	Bit 2	Bit 1	Bit 0
DDC_AR2	0019h	W	X0h	DAR27	DAR26	DAR25	DAR24	DAR23	DAR22	DAR21	ENAR2

Bit Name	Description
DAR27~ DAR21	7-bit DDC address to be compared. DAR27 is compared with the MSB of the received address.
ENAR2	Enable DAR27- DAR21 to be compared when this bit is set.

### DDC Flow Chart

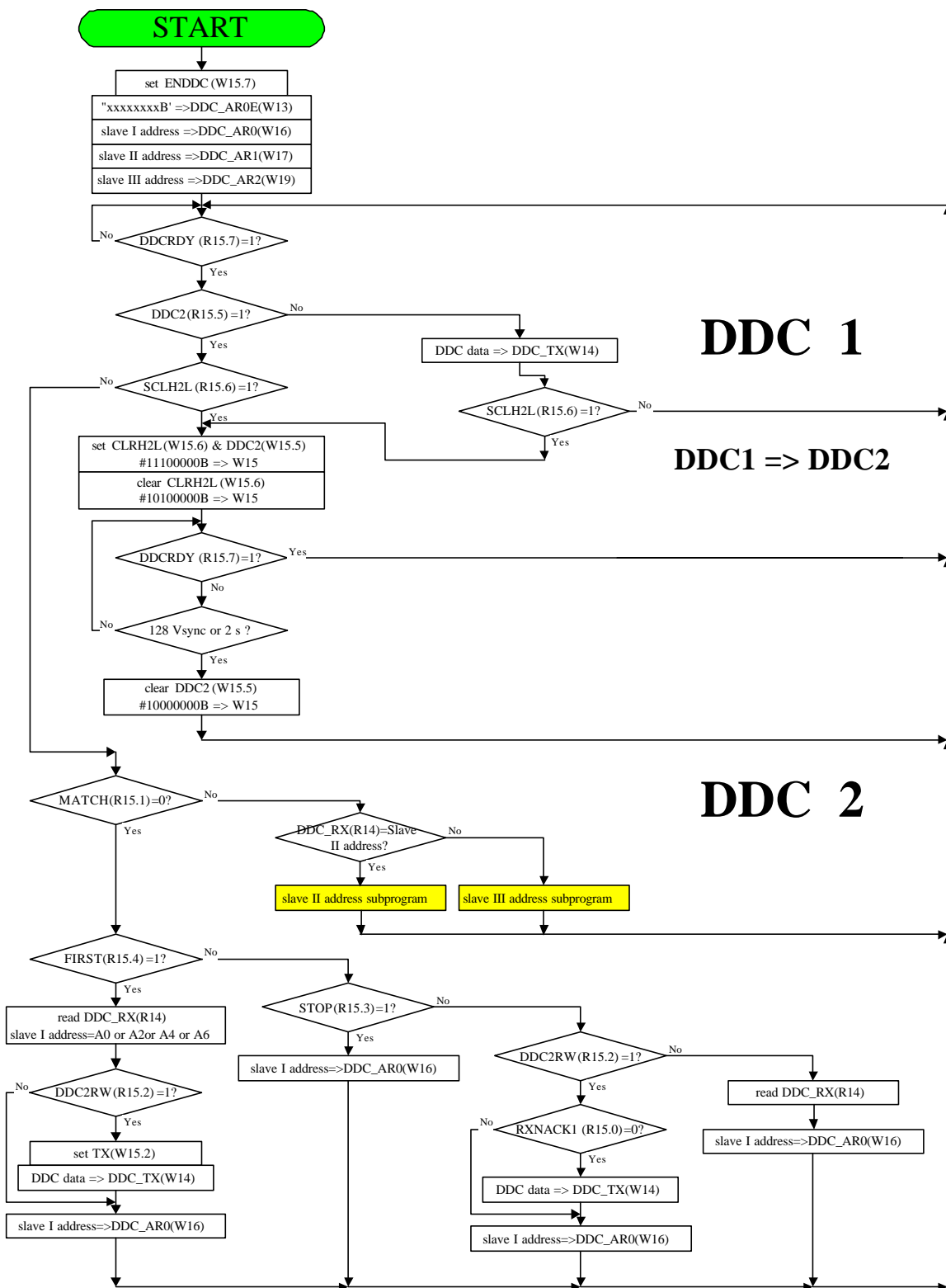

## Master/Slave I<sup>2</sup>C interface

The master/slave I<sup>2</sup>C interface is provided for communicating with other I<sup>2</sup>C devices in the monitor such as EEPROM, OSD, deflection IC and so on.

### Master Mode

To choose master mode, clear the SLAVE bit. The clock frequency can be programmed to 50KHz, 100kHz, 200kHz or 400kHz by setting MCLK1 and MCLK2 bits.

#### Send out START and the first byte (START, 7-bit address and R/W bit)

First, clear I2CRW bit to select transmitter mode and write first byte (7-bit address and R/W bit) to MI2C\_TX register. Then set MSTR bit, master will generate a START condition and send out the first byte with the clock speed specified in MCLK1 and MCLK2 bits. After the whole data byte is transmitted and the 9th bit is received, the MI2CRDY bit is set and generates an interrupt if it is enabled. The 9th bit will be stored in RXNAK2 bit for checking the slave acknowledge or not. The SCL2 pin will keep low to wait next byte operation.

#### Send out the following bytes

If it is a write command, write a data byte to MI2C\_TX register, then write any value to I2C\_AR register to clear MI2CRDY bit. It will send out the data byte and store the acknowledge bit from slave in RXACK2 bit. Again, the MI2CRDY bit is set after the acknowledge bit is received.

If it is a read command, set I2CRW bit to be receiver mode and write TXACK2 bit to determine what will be sent on acknowledge bit, then write MI2C\_AR register to clear I2CRDY bit and it will send out the clock for receiving next byte. After the acknowledge bit is transmitted, the I2CRDY bit will be set. If master wants to stop the read operation, send NACK on acknowledge bit to inform slave device.

#### Send out STOP

Set MSTOP bit will generate STOP condition.

### Slave Mode

The slave mode operation is same as DDC interface in DDC2 state. First, set the SLAVE bit and set the I2CRW bit to be receiver mode. When CPU is ready to receive, clear TXNAK2 bit. It will response ACK when a START condition followed by an address (which is equal to I2C\_ADR register) are received. An interrupt can be generated if it is enabled and the R/W bit is stored in SRW bit for checking read/write operation. After the ACK bit, SCL2 pin outputs low level to stop the clock for handshaking. Add the function that one master access multi-slave when WT6148/ WT6160 in slave mode

If a write command is received (SRW bit=0), read the I2C\_RX register, clear I2CRW bit to receive next byte, then write I2C\_ADR to clear I2CRDY bit and stop pulling low the SCL2 pin for receiving next byte from master. The output acknowledge bit is controlled by TX NAK2 bit.

If a read command is received (SRW bit=1), write data to I2C\_TX register, clear I2CRW bit and write I2C\_ADR register to clear I2CRDY bit and stop pulling low the SCL2 pin for master sending out clock The received acknowledge bit is stored in RXNAK2 bit.

### Master I<sup>2</sup>C Data Sequence

#### (1) Write mode :

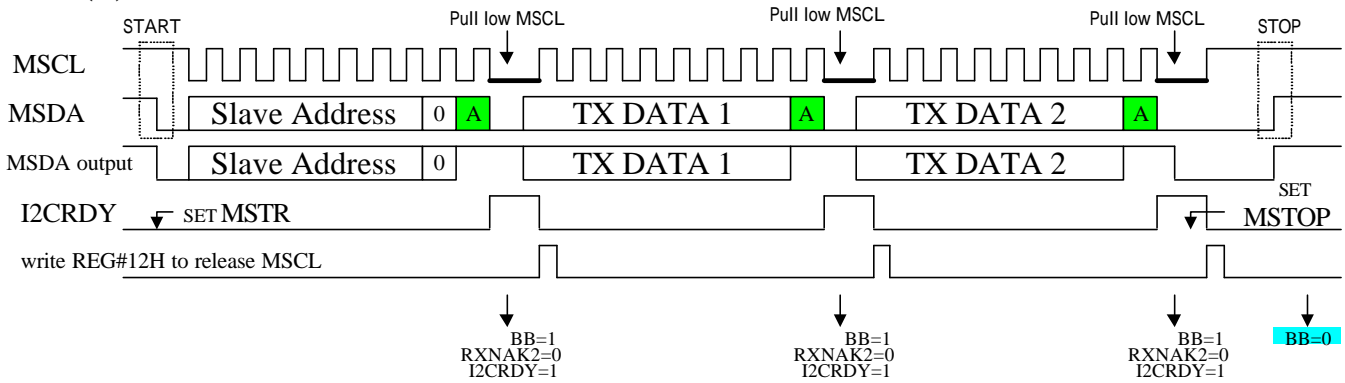

#### (2) Read mode (I) :

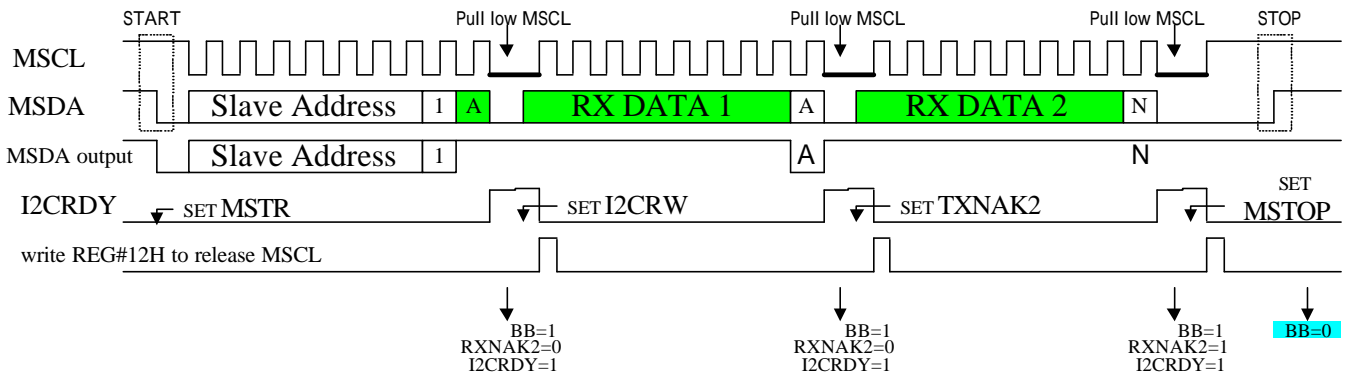

#### (3) Read mode (II) :

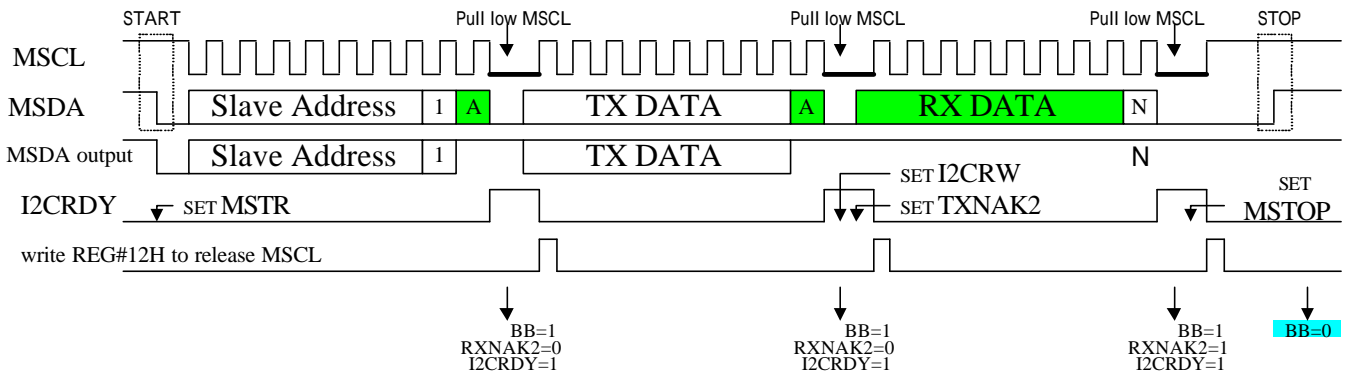

### Slave I<sup>2</sup>C Data Sequence

#### (1) Write mode :

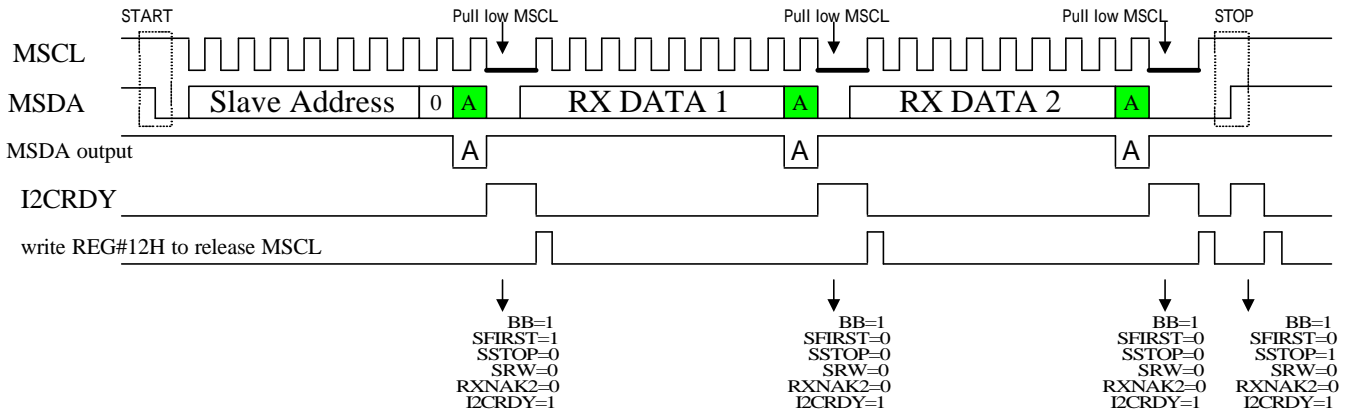

#### (2) Read mode (I) :

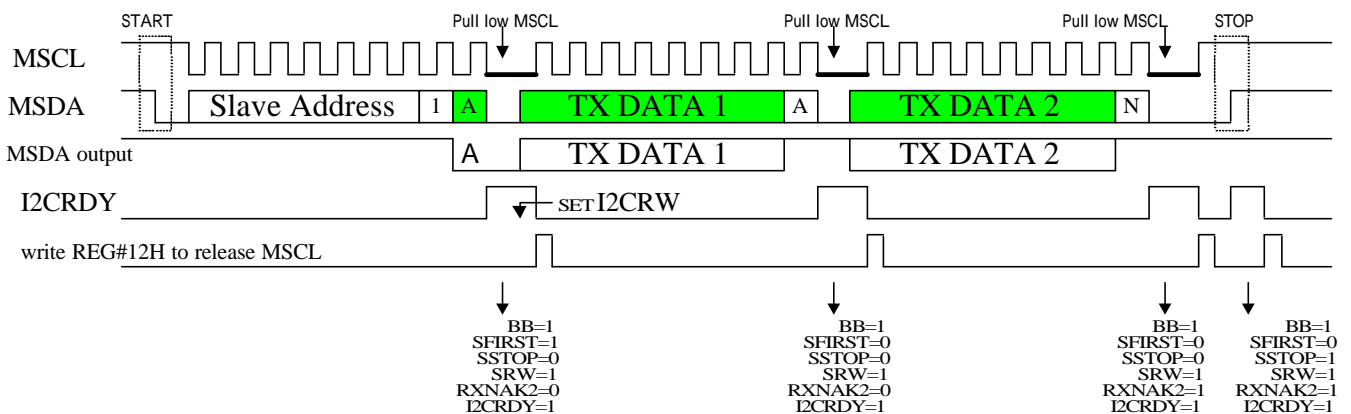

#### (3) Read mode (II) :

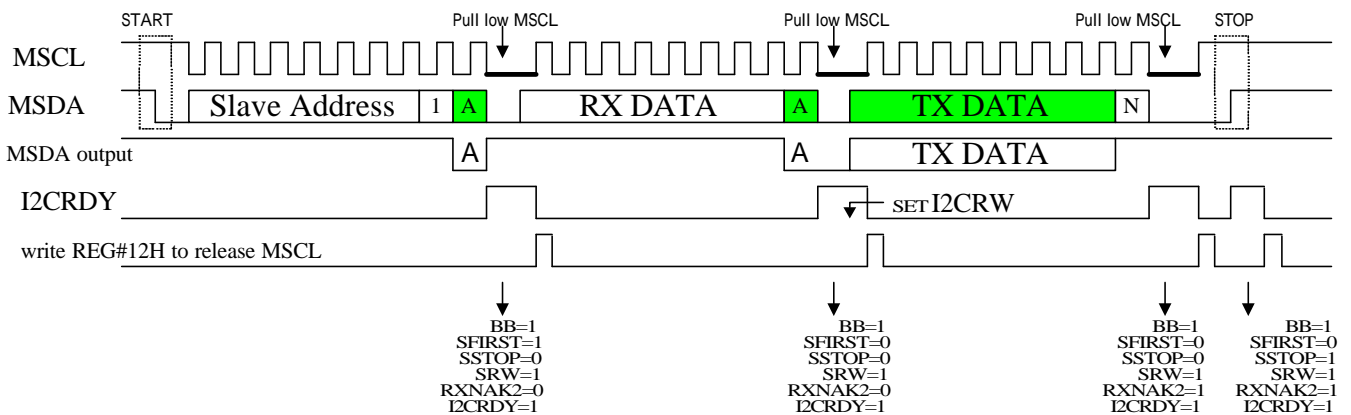



**I<sup>2</sup>C interface Status Register**

Name	Addr	R/W	Initial	Bit 7	Bit 6	Bit 5	Bit4	Bit 3	Bit 2	Bit 1	Bit 0
I2C_STA	0010h	R	22h	--	--	BB	SFIRST	SSTOP	SRW	RXNAK2	I2CRDY

Bit Name	Description
BB	"1" : Bus busy. "0" : Bus idle. Both SDA2 and SCL2 pins keep in high level for 5us after STOP condition.
SFIRST	This bit is set when received START and first byte in slave mode.
SSTOP	This bit is set when received STOP condition in slave mode.
SRW	Received R/W bit in slave mode. "1" : Read command is received. "0" : Write command is received.
RXNAK2	"1" : NACK is received. "0" : ACK is received.
I2CRDY	This bit is set when a byte is received, transmitted or STOP condition is detected.

**I<sup>2</sup>C interface Control Register**

Name	Addr	R/W	Initial	Bit 7	Bit 6	Bit 5	Bit4	Bit 3	Bit 2	Bit 1	Bit 0
I2C_CON	0010h	W	02h	ENI2C	MCLK1	MCLK0	MSTR	MSTOP	I2CRW	TXNAK2	SLAVE

Bit Name	Description
ENI2C	"1" : Enable I2C interface. "0" : Pin PB5 and pin PB4 are I/O port.
MCLK1,0	Select SCL clock in master mode "00" : 400KHz "01" : 100KHz "11" : 200KHz "10" : 50KHz
MSTR	Output START condition in master mode when this bit is set.
MSTOP	Output STOP condition in master mode when this bit is set.
I2CRW	"0" : Transmitter , "1" : Receiver in master mode. "1" : Transmitter , "0" : Receiver in slave mode ( "0" : I2C write mode, "1" : I2C read mode. )
TXNAK2	"1" : Output NACK. "0" : Output ACK. It will pull low the SDA2 pin on acknowledge bit.
SLAVE	"1" : Slave mode. "0" : Master mode.

**I<sup>2</sup>C interface Transmit/Receive Buffer Register**

Name	Addr	R/W	Initial	Bit 7	Bit 6	Bit 5	Bit4	Bit 3	Bit 2	Bit 1	Bit 0
I2C_TX	0011h	W	xxh	MTX7	MTX6	MTX5	MTX4	MTX3	MTX2	MTX1	MTX0
I2C_RX	0011h	R	xxh	MRX7	MRX6	MRX5	MRX4	MRX3	MRX2	MRX1	MRX0

**I<sup>2</sup>C interface Address Register**

Name	Addr	R/W	Initial	Bit 7	Bit 6	Bit 5	Bit4	Bit 3	Bit 2	Bit 1	Bit 0
I2C_ADR	0012h	W	xxh	SAR7	SAR6	SAR5	SAR4	SAR3	SAR2	SAR1	--

Bit Name	Description
SAR7 ~ SAR1	7-bit address to be compared in slave mode.

### Master I<sup>2</sup>C Flow Chart

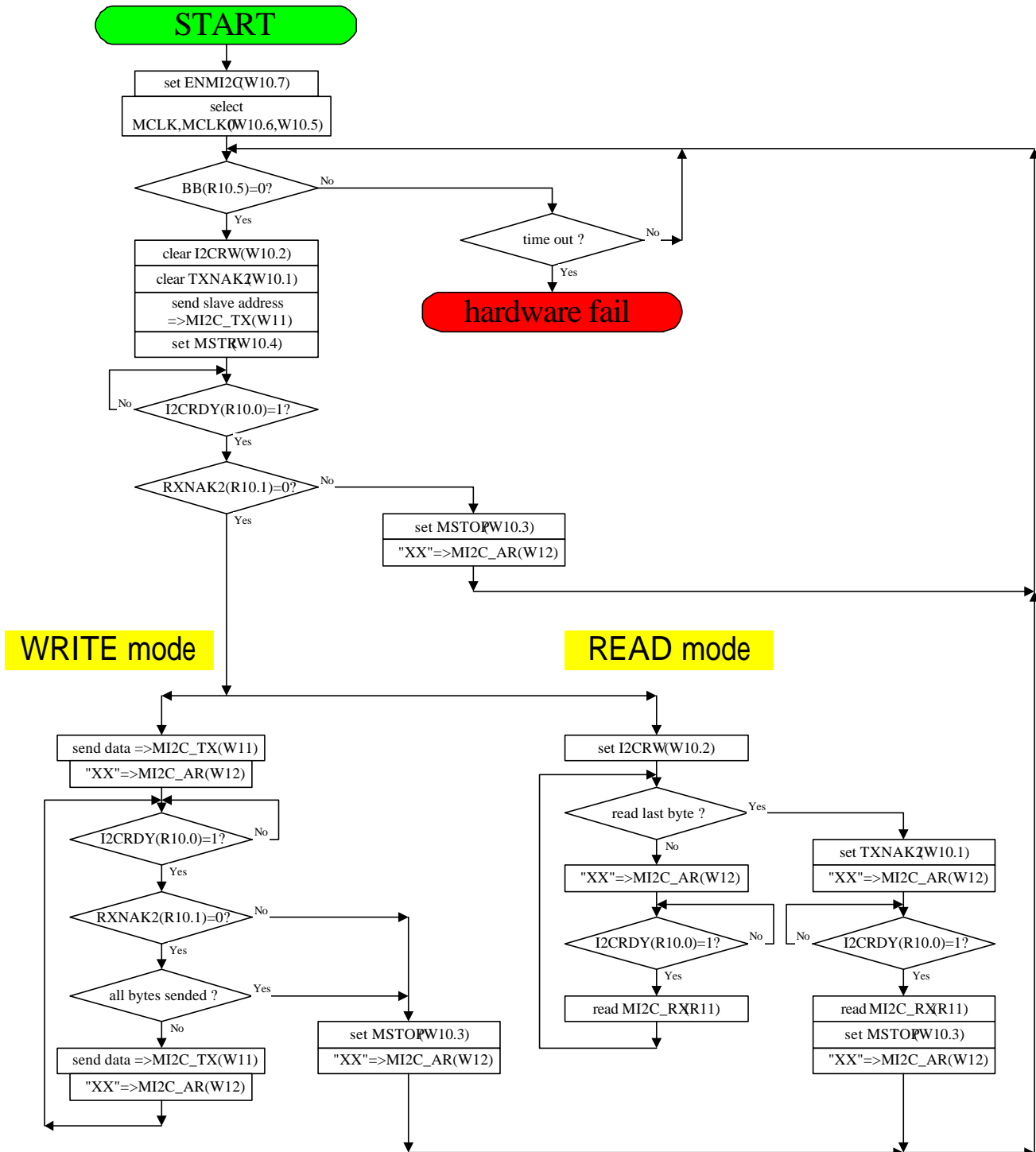

### Master I<sup>2</sup>C (restart mode) Flow Chart

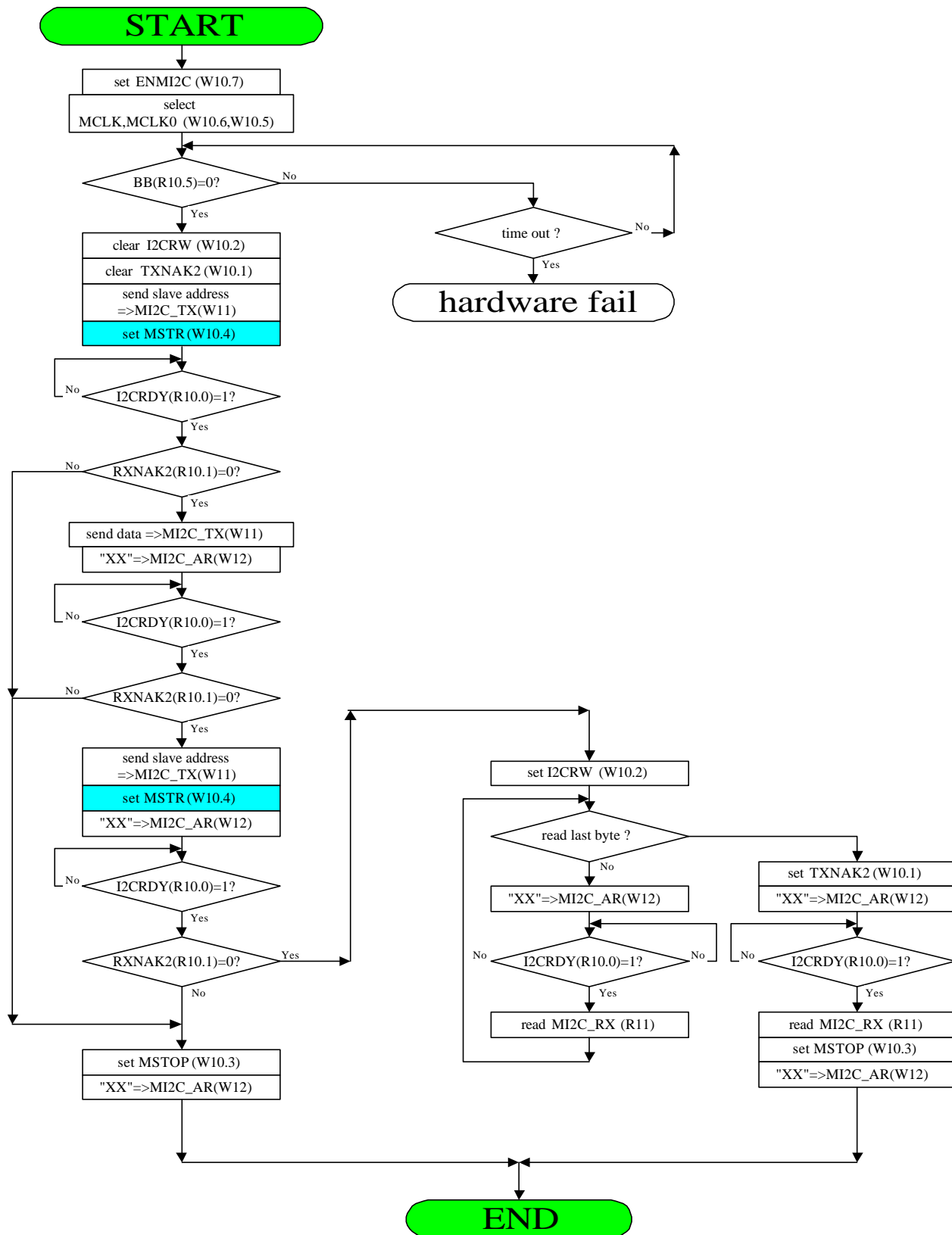



**Slave I<sup>2</sup>C Flow Chart**

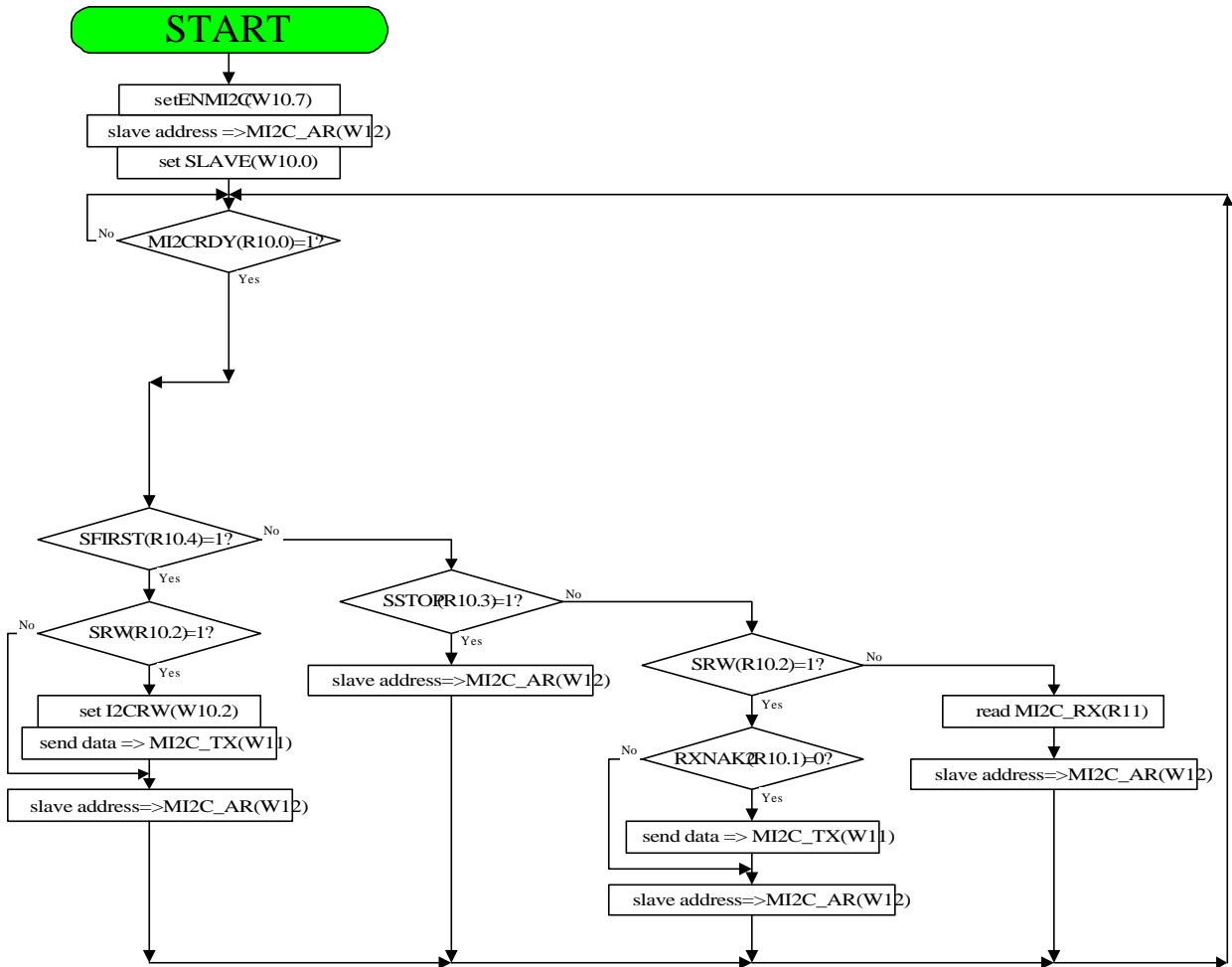

### Timer

It is a 6-bit down counter with 2-bit prescaler. The time base is selected by PS1 and PS0 bits. Timer starts counting when writing data to TIMER register. When the counter reaches zero, the counter stops and sets interrupt flag (IF\_TMR). If program wants to start the timer again, write data to TIMER register.

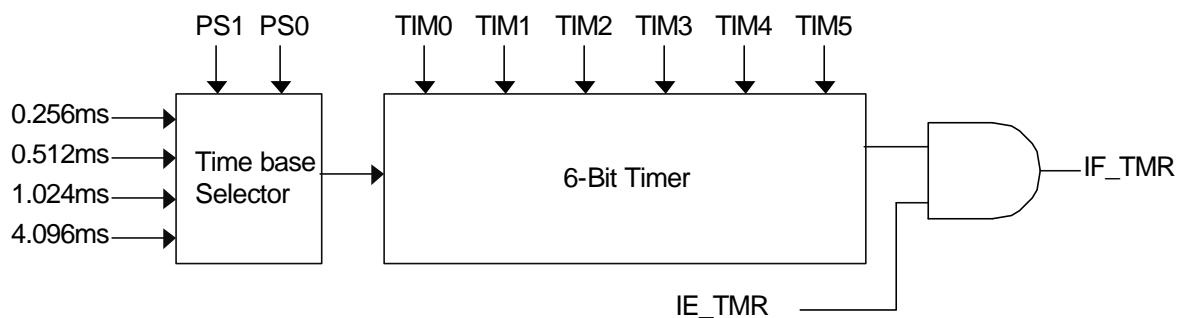

Fig.11 Block diagram of Timer

### Timer Register

Name	Addr	R/W	Initial	Bit 7	Bit 6	Bit 5	Bit 4	Bit 3	Bit 2	Bit 1	Bit 0
TIMER	0018h	W	00h	PS1	PS0	TIM5	TIM4	TIM3	TIM2	TIM1	TIM0

Bit Name	Bit Description
PS1,PS0	Prescaler of timer. "00" : time base = 0.256ms "01" : time base = 0.512ms "10" : time base = 1.024ms "11" : time base = 4.096ms
TIM5 ~ TIM0	Timer period = time base x (6-bit data) + ( 0 --1 ) x time base



**A/D converter**

The Analog-to-Digital Converter (ADC) has 6bit resolution with four selectable input channels. When EN\_CHx is set, PCx is configured as ADC input and PCx pull-high resistor is disabled. When CHx is set, it will reset the ADC\_DA register and start converting. After the conversion is done, the ADRDY bit is set and valid data is stored in AD5~AD0 bits. The total conversion time is from 512us to 1.024ms. If program want to make a new conversion, write CHx register again and it will start another conversion.

**ADC Data Register**

Name	Addr	R/W	Initial	Bit 7	Bit 6	Bit 5	Bit4	Bit 3	Bit 2	Bit 1	Bit 0
ADC_DA	001Ah	R	0xh	ADRDY	--	AD5	AD4	AD3	AD2	AD1	AD0

Bit Name	Bit Description
ADRDY	ADC data is ready to read when this bit is set.
AD5 ~ AD0	ADC data.

**ADC Channel Select Register**

Name	Addr	R/W	Initial	Bit 7	Bit 6	Bit 5	Bit4	Bit 3	Bit 2	Bit 1	Bit 0
ADC_CH	001Ah	W	00h	EN_CH3	EN_CH2	EN_CH1	EN_CH0	CH3	CH2	CH1	CH0

Bit Name	Bit Description
EN_CH3	"1" : PC3 is configured as ADC interface. (Disable PC3 pull-high resistor). "0" : PC3 is configured as I/O port.
EN_CH2	"1" : PC2 is configured as ADC interface. (Disable PC2 pull-high resistor). "0" : PC2 is configured as I/O port.
EN_CH1	"1" : PC1 is configured as ADC interface. (Disable PC1 pull-high resistor). "0" : PC1 is configured as I/O port.
EN_CH0	"1" : PC0 is configured as ADC interface. (Disable PC0 pull-high resistor). "0" : PC0 is configured as I/O port.
CH3	Select AD3 pin to ADC convert when this bit is set.
CH2	Select AD2 pin to ADC convert when this bit is set.
CH1	Select AD1 pin to ADC convert when this bit is set.
CH0	Select AD0 pin to ADC convert when this bit is set.

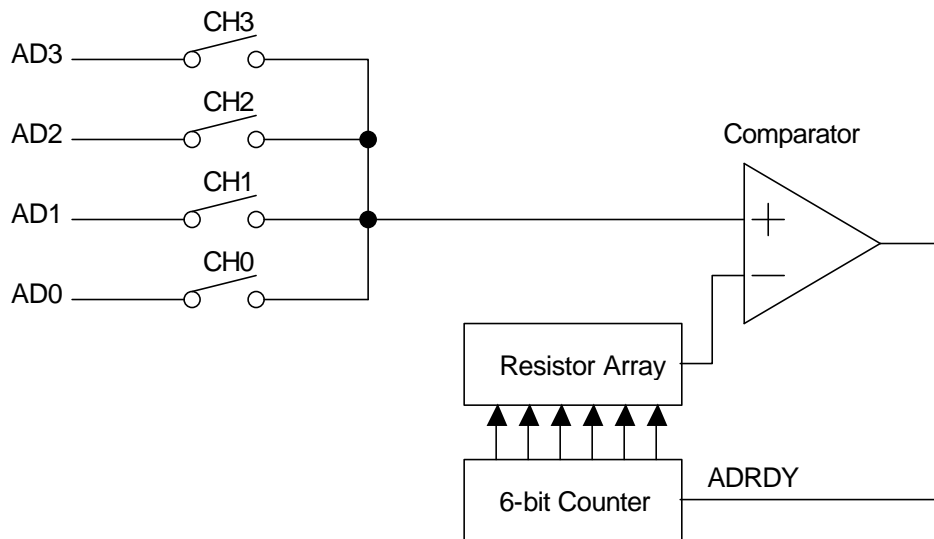

**Fig.12 Block diagram of ADC**

## A/D Converter Flow Chart

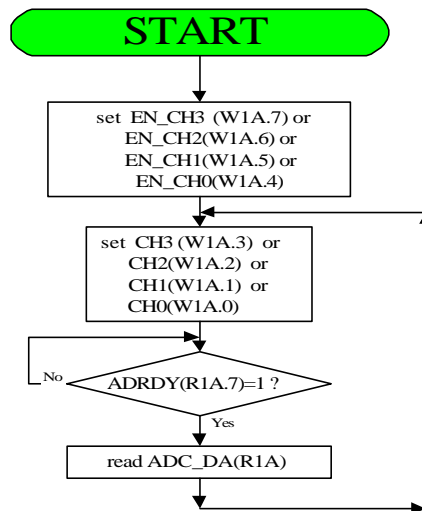

## Interrupt Control

There are two interrupt vectors of CPU. The high priority interrupt INT0 (vector in \$FFFAh and \$FFFBh) is used for DDC interface interrupt. The low priority INT1 (vector in \$FFFEh and \$FFFFh) is ORed by six interrupt sources. Each interrupt can be enabled/disabled independently by programming INT\_EN register and identified by INT\_FLAG register.

### DDC interface interrupt

Interrupt Condition	Clear Interrupt
Transmit data buffer is empty in DDC1 mode.	Write data to DDC_RX register.
A high to low transition on SCL1 pin in DDC1 mode.	Set CLRH2L bit in DDC_CON register and clear it .
Receive one byte in DDC2 mode.	Write address to DDC_AR0 register.
Transmit data buffer is empty in DDC2 mode.	Write address to DDC_AR0 register.
Received a STOP condition in DDC2 mode.	Write address to DDC_AR0 register.

### I<sup>2</sup>C interface interrupt

Interrupt Condition	Clear Interrupt
After transmit a byte.	Write address to MI2C_AR register.
After receive a byte.	Write address to MI2C_AR register.
Received a STOP condition.	Write address to MI2C_AR register.

### Sync Processor interrupt

Interrupt Condition	Clear Interrupt
Latch a new H frequency to HFREQ_H and HFREQ_L register every 32.768ms or 16.384ms.	Read HFREQ_H Register.

### Timer interrupt

Interrupt Condition	Clear Interrupt
Timer expired.	Write a value to TIMER register

### IRQ pin interrupt

Interrupt Condition	Clear Interrupt
Low level or falling edge on /IRQ pin.	Set CLR_IRQ bit in IRQ_CON register and clear it .

### Vsync output interrupt

Interrupt Condition	Clear Interrupt
Leading edge of VOUT pin signal.	Set CLR_VSO bit in IRQ_CON register and clear it .

### Vsync input interrupt

Interrupt Condition	Clear Interrupt
Leading edge of VIN pin signal.	Set CLR_VIN bit in IRQ_CON register and clear it .

### Interrupt Flag Register

Name	Addr	R/W	Initial	Bit 7	Bit 6	Bit 5	Bit4	Bit 3	Bit 2	Bit 1	Bit 0
INT_FLAG	001Bh	R	00h	IF_DDC	IF_MI2C	--	IF_SYNC	IF_TMR	IF_IRQ	IF_VSO	IF_VIN



Bit Name	Bit Description
IF_DDC	Indicate DDC interrupt when this bit is set.
IF_MI2C	Indicate I2C interrupt when this bit is set.
IF_SYNC	Indicate sync processor interrupt when this bit is set.
IF_TMR	Indicate Timer interrupt when this bit is set.
IF_IRQ	Indicate IRQ interrupt when this bit is set.
IF_VSO	Indicate VOUT interrupt when this bit is set.
IF_VIN	Indicate VIN interrupt when this bit is set.

**Interrupt Enable Register**

Name	Addr	R/W	Initial	Bit 7	Bit 6	Bit 5	Bit4	Bit 3	Bit 2	Bit 1	Bit 0
INT_EN	001Bh	W	00h	IE_DDC	IE_MI2C	--	IE_SYNC	IE_TMR	IE_IRQ	IE_VSO	IE_VIN

Bit Name	Bit Description
IE_DDC	Enable DDC interrupt when this bit is set.
IE_MI2C	Enable I2C interrupt when this bit is set.
IE_SYNC	Enable sync processor interrupt when this bit is set.
IE_TMR	Enable Timer interrupt when this bit is set.
IE_IRQ	Enable IRQ interrupt when this bit is set.
IE_VSO	Enable VOUT interrupt when this bit is set.
IE_VIN	Enable VIN interrupt when this bit is set.

**Interrupt Source Register**

Name	Addr	R/W	Initial	Bit 7	Bit 6	Bit 5	Bit4	Bit 3	Bit 2	Bit 1	Bit 0
INT_SRC	001Ch	R		--	--	--	SYNC	TIMER	IRQ	VSO	VIN

Bit Name	Bit Description
SYNC	Indicate H frequency counter is ready to read when this bit is set..
TIMER	Indicate Timer expired when this bit is set.
IRQ	Indicate a low level or falling edge occurs on IRQ pin when this bit is set.
VSO	Indicate a leading edge occurs on VOUT pin when this bit is set.
VIN	Indicate a leading edge occurs on VIN pin when this bit is set.

**IRQ Control Register**

Name	Addr	R/W	Initial	Bit 7	Bit 6	Bit 5	Bit4	Bit 3	Bit 2	Bit 1	Bit 0
IRQ_CON	001Ch	W	00h	--	--	--	--	CLR_VIN	CLR_IRQ	CLR_VSO	IRQ_EG

Bit Name	Bit Description
CLR_IRQ	Clear IRQ interrupt when this bit is set.
CLR_VSO	Clear VOUT interrupt when this bit is set.
CLR_VIN	Clear Vsync input interrupt when this bit is set.
IRQ_EG	Select IRQ pin interrupt type. "1" : Falling edge "0" : Low level



**Watchdog Timer**

Watchdog timer will generate a reset pulse if CPU does not write WDT register within 259.072ms or 518.144ms. This function can be disabling by setting DISWDT bit.

**Watchdog Timer Register**

Name	Addr	R/W	Initial	Bit 7	Bit 6	Bit 5	Bit4	Bit 3	Bit 2	Bit 1	Bit 0
WDT	001Dh	W	00h	--	--	--	--	--	--	DISWDT	WDT

Bit Name	Description
DISWDT	“1” : Disable Watchdog Timer. “0” : Enable Watchdog Timer.
WDT	“1” : Watchdog Timer reset period is 518.144ms $\pm$ 8.096ms. “0” : Watchdog Timer reset period is 259.072ms $\pm$ 8.096ms.

**Function Configuration Register**

This register controls the special configuration of WT6148/ WT6160.

Name	Addr	R/W	Initial	Bit 7	Bit 6	Bit 5	Bit4	Bit 3	Bit 2	Bit 1	Bit 0
OPTION	0FFFh	W	00h		--	--	--	DIRST	STEST		

Bit Name	Bit Value = “1”	Bit Value = “0”
STEST	For IC test only. Do not set this bit.	For normal operation.
DIRST	Disable illegal address reset.	Enable illegal address reset.

### PWM

There are 14 PWMs provided.

PWM0 ~ PWM1 : +5V open-drain output.

PWM2 ~ PWM3 : +10V open-drain output.

PWM4 ~ PWM7 : +5V open-drain output, shared with I/O port D.

PWM8 ~ PWM13 : +5V push-pull output, shared with I/O port A.

The corresponding PWM register controls the PWM duty cycle. Duty cycle range is from 0/256 to 255/256.

LSB 3-bit of PWM register determines which frame will be extended two T<sub>osc</sub>. ( T<sub>osc</sub> = 1/12MHz)

000 : no extended pulse.

001 : extend two T<sub>osc</sub> in frame 4.

010 : extended two T<sub>osc</sub> in frame 2 and 6.

011 : extended two T<sub>osc</sub> in frame 2, 4 and 6.

100 : extended two T<sub>osc</sub> in frame 1, 3, 5 and 7.

101 : extended two T<sub>osc</sub> in frame 1, 3, 4, 5 and 7.

110 : extended two T<sub>osc</sub> in frame 1, 2, 3, 5, 6 and 7.

111 : extended two T<sub>osc</sub> in frame 1, 2, 3, 4, 5, 6 and 7.

MSB 5-bit of PWM register determines 0/32 to 31/32 duty cycle in each frame.

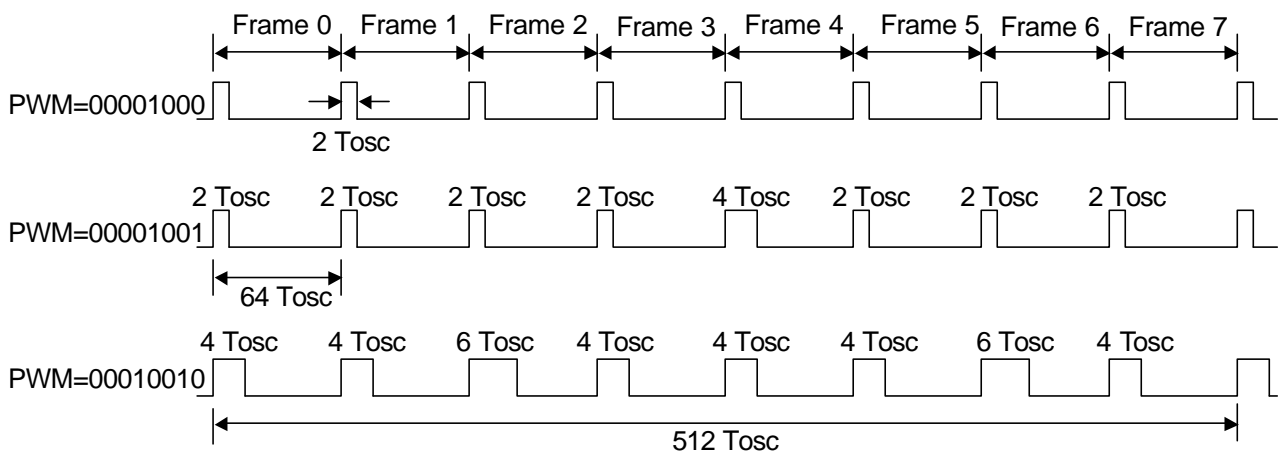

**Fig. 13 PWM output waveform**





**PWM Registers**

Name	Addr	R/W	Initial	Bit 7	Bit 6	Bit 5	Bit4	Bit 3	Bit 2	Bit 1	Bit 0
PWM0	0020h	R/W	80h	PWM0 <sub>7</sub>	PWM0 <sub>6</sub>	PWM0 <sub>5</sub>	PWM0 <sub>4</sub>	PWM0 <sub>3</sub>	PWM0 <sub>2</sub>	PWM0 <sub>1</sub>	PWM0 <sub>0</sub>
PWM1	0021h	R/W	80h	PWM1 <sub>7</sub>	PWM1 <sub>6</sub>	PWM1 <sub>5</sub>	PWM1 <sub>4</sub>	PWM1 <sub>3</sub>	PWM1 <sub>2</sub>	PWM1 <sub>1</sub>	PWM1 <sub>0</sub>
PWM2	0022h	R/W	80h	PWM2 <sub>7</sub>	PWM2 <sub>6</sub>	PWM2 <sub>5</sub>	PWM2 <sub>4</sub>	PWM2 <sub>3</sub>	PWM2 <sub>2</sub>	PWM2 <sub>1</sub>	PWM2 <sub>0</sub>
PWM3	0023h	R/W	80h	PWM3 <sub>7</sub>	PWM3 <sub>6</sub>	PWM3 <sub>5</sub>	PWM3 <sub>4</sub>	PWM3 <sub>3</sub>	PWM3 <sub>2</sub>	PWM3 <sub>1</sub>	PWM3 <sub>0</sub>
PWM4	0024h	R/W	80h	PWM4 <sub>7</sub>	PWM4 <sub>6</sub>	PWM4 <sub>5</sub>	PWM4 <sub>4</sub>	PWM4 <sub>3</sub>	PWM4 <sub>2</sub>	PWM4 <sub>1</sub>	PWM4 <sub>0</sub>
PWM5	0025h	R/W	80h	PWM5 <sub>7</sub>	PWM5 <sub>6</sub>	PWM5 <sub>5</sub>	PWM5 <sub>4</sub>	PWM5 <sub>3</sub>	PWM5 <sub>2</sub>	PWM5 <sub>1</sub>	PWM5 <sub>0</sub>
PWM6	0026h	R/W	80h	PWM6 <sub>7</sub>	PWM6 <sub>6</sub>	PWM6 <sub>5</sub>	PWM6 <sub>4</sub>	PWM6 <sub>3</sub>	PWM6 <sub>2</sub>	PWM6 <sub>1</sub>	PWM6 <sub>0</sub>
PWM7	0027h	R/W	80h	PWM7 <sub>7</sub>	PWM7 <sub>6</sub>	PWM7 <sub>5</sub>	PWM7 <sub>4</sub>	PWM7 <sub>3</sub>	PWM7 <sub>2</sub>	PWM7 <sub>1</sub>	PWM7 <sub>0</sub>
PWM8	0028h	R/W	80h	PWM8 <sub>7</sub>	PWM8 <sub>6</sub>	PWM8 <sub>5</sub>	PWM8 <sub>4</sub>	PWM8 <sub>3</sub>	PWM8 <sub>2</sub>	PWM8 <sub>1</sub>	PWM8 <sub>0</sub>
PWM9	0029h	R/W	80h	PWM9 <sub>7</sub>	PWM9 <sub>6</sub>	PWM9 <sub>5</sub>	PWM9 <sub>4</sub>	PWM9 <sub>3</sub>	PWM9 <sub>2</sub>	PWM9 <sub>1</sub>	PWM9 <sub>0</sub>
PWM10	002Ah	R/W	80h	PWM10 <sub>7</sub>	PWM10 <sub>6</sub>	PWM10 <sub>5</sub>	PWM10 <sub>4</sub>	PWM10 <sub>3</sub>	PWM10 <sub>2</sub>	PWM10 <sub>1</sub>	PWM10 <sub>0</sub>
PWM11	002Bh	R/W	80h	PWM11 <sub>7</sub>	PWM11 <sub>6</sub>	PWM11 <sub>5</sub>	PWM11 <sub>4</sub>	PWM11 <sub>3</sub>	PWM11 <sub>2</sub>	PWM11 <sub>1</sub>	PWM11 <sub>0</sub>
PWM12	002Ch	R/W	80h	PWM12 <sub>7</sub>	PWM12 <sub>6</sub>	PWM12 <sub>5</sub>	PWM12 <sub>4</sub>	PWM12 <sub>3</sub>	PWM12 <sub>2</sub>	PWM12 <sub>1</sub>	PWM12 <sub>0</sub>
PWM13	002Dh	R/W	80h	PWM13 <sub>7</sub>	PWM13 <sub>6</sub>	PWM13 <sub>5</sub>	PWM13 <sub>4</sub>	PWM13 <sub>3</sub>	PWM13 <sub>2</sub>	PWM13 <sub>1</sub>	PWM13 <sub>0</sub>
PWM_EN1	002Eh	W	00h	--	--	--	--	EPWM7	EPWM6	EPWM5	EPWM4
PWM_EN2	002Fh	W	00h	--	--	EPWM13	EPWM12	EPWM11	EPWM10	EPWM9	EPWM8

Bit Name	Description
PWMX <sub>7</sub> ~ PWMX <sub>0</sub>	Select duty cycle of PWM output. 00000000 : duty cycle = 0 00000001 : duty cycle = 1/256 00000010 : duty cycle = 2/256 : 11111110 : duty cycle = 254/256 11111111 : duty cycle = 255/256
EPWMx	Enable corresponding PWM output. ( x from 4 to 13) when it is set.

## ELECTRICAL CHARACTERISTICS

### Absolute Maximum Ratings

Parameter	Min.	Max.	Units
DC Supply Voltage (VDD)	-0.3	7.0	V
Input and output voltage with respect to Ground	-0.3	VDD+0.3	V
Storage temperature	-25	125	°C
Ambient temperature with power applied	-10	85	°C

**\*Note: Stresses above those listed may cause permanent damage to the devices**

### D.C Characteristics (VDD=5.0V±5%, Ta=0-70°C)

Symbol	Parameter	Condition	Min.	Typ.	Max.	Units
V <sub>DD</sub>	Supply Voltage		4.5	5	5.5	V
V <sub>IH</sub>	Input High Voltage		0.7V <sub>DD</sub>	--	V <sub>DD</sub> +0.3	V
V <sub>IL</sub>	Input Low Voltage		-0.3	--	0.2V <sub>DD</sub>	V
V <sub>IH,SYNC</sub>	Sync Input High Voltage (Schmitt trigger)		2	--	V <sub>DD</sub> +0.3	V
V <sub>IL,SYNC</sub>	Sync Input Low Voltage (Schmitt trigger)		-0.3	--	0.8	V
V <sub>IH,RES</sub>	Reset Input High Voltage (Schmitt trigger)		2	--	V <sub>DD</sub> +0.3	V
V <sub>IL,RES</sub>	Reset Input Low Voltage (Schmitt trigger)		-0.3	--	0.8	V
V <sub>OH</sub>	Output High Voltage	I <sub>OH</sub> = -6mA	4	4.5	V <sub>DD</sub>	V
V <sub>OL</sub>	Output Low Voltage	I <sub>OL</sub> = 6mA	0	0.26	0.4	V
	PORT C Output Low Voltage	I <sub>OL</sub> = 10mA	0	0.26	0.4	V
	PWM0,PWM1,PWM2,PWM3 Output Low Voltage	I <sub>OL</sub> = 10mA	0	0.26	0.4	V
I <sub>IL,SYNC</sub>	Input Leakage Current HSYNC and VSYNC pins	0V < V <sub>IN</sub> < V <sub>DD</sub>	-1	--	1	μA
R <sub>PH</sub>	Pull High Resistance			20	50	Kohm
I <sub>DD</sub>	Operating Current	F <sub>OSC</sub> = 12MHz, No load		12	30	mA
V <sub>RESET</sub>	Low V <sub>DD</sub> Reset Voltage		3.6	3.9	4.2	V

### A.C Characteristics (VDD=5.0V±5%, fosc=12MHz, Ta=0-70°C)

#### /RESET and /IRQ Timing

Symbol	Parameter	Min.	Typ.	Max.	Units
$t_{LOW,RES}$	/RESET pin low pulse	167	-	-	ns
$t_{LOW,IRQ}$	/IRQ low pulse (level trigger)	167	-	-	ns

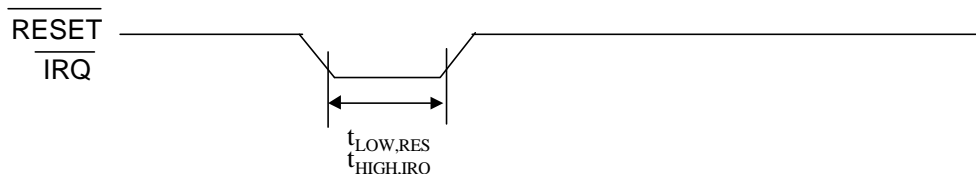

#### SYNC Processor Timing

Symbol	Parameter	Min.	Typ.	Max.	Units
$t_{HIGH,SYNC}$	HSYNC and VSYNC high time	167	-	-	ns
$t_{LOW,SYNC}$	HSYNC and VSYNC low time	167	-	-	ns

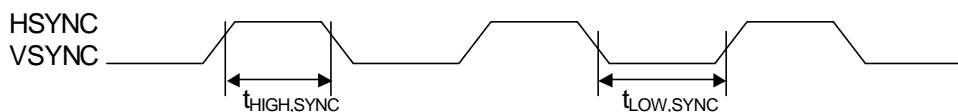

#### DDC1 Timing

Symbol	Parameter	Min.	Typ.	Max.	Units
$t_{VAA,DDC1}$	SDA1 output valid from VSYNC rising edge	125	-	500	ns

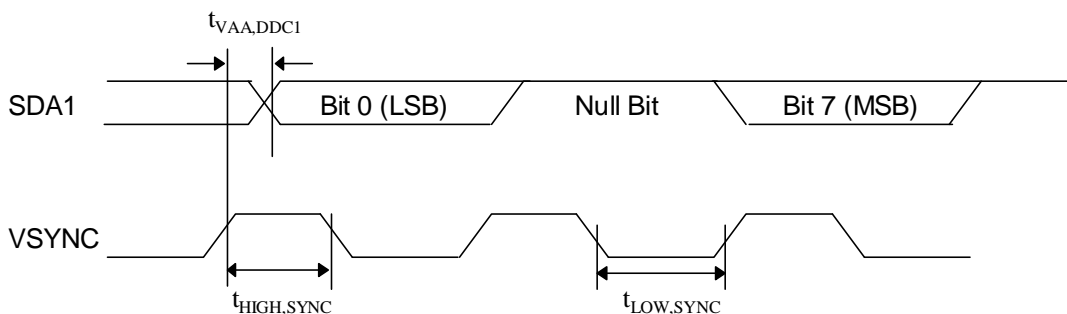

**DDC2B Timing**

Symbol	Parameter	Min.	Typ.	Max.	Units
$f_{SCL}$	SCL1 input clock frequency	0	-	100	kHz
$t_{BF}$	Bus free time	2	-	-	us
$t_{HD,START}$	Hold time for START condition	1	-	-	us
$t_{SU,START}$	Set-up time for START condition	1	-	-	us
$t_{HIGH,SCL}$	SCL1 clock high time	1	-	-	us
$t_{LOW,SCL}$	SCL1 clock low time	1	-	-	us
$t_{HD,DATA}$	Hold time for DATA input	0	-	-	ns
	Hold time for DATA output	167	-	-	ns
$t_{SU,DATA}$	Set-up time for DATA input	167	-	-	ns
	Set-up time for DATA output	334	-	-	ns
$t_{RISE,DDC}$	SCL1 and SDA1 rise time	-	-	1	us
$t_{FALL,DDC}$	SCL1 and SDA1 fall time	-	-	300	ns
$t_{SU,STOP}$	Set-up time for STOP condition	2	-	-	us

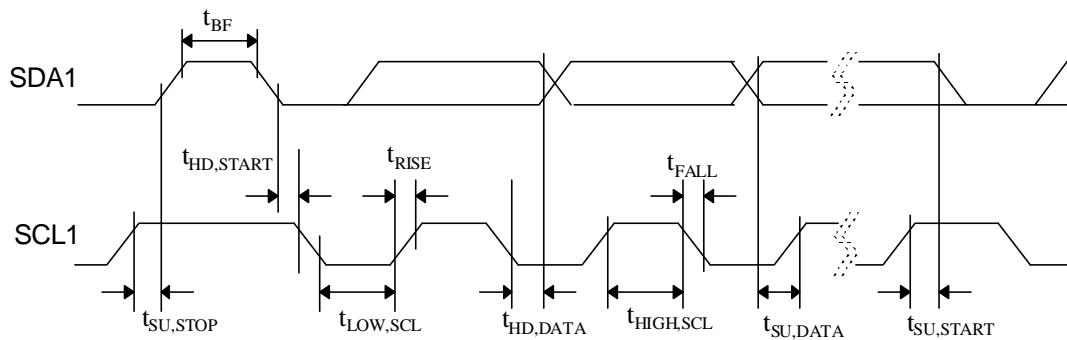

### TYPICAL APPLICATION CIRCUIT

#### Reset Pin and Crystal Oscillator

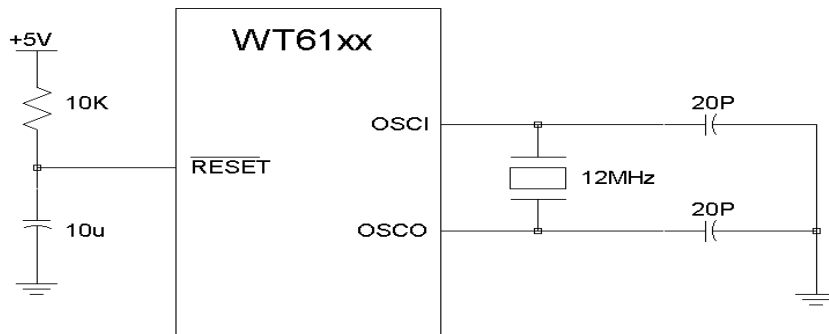

#### PWM Output

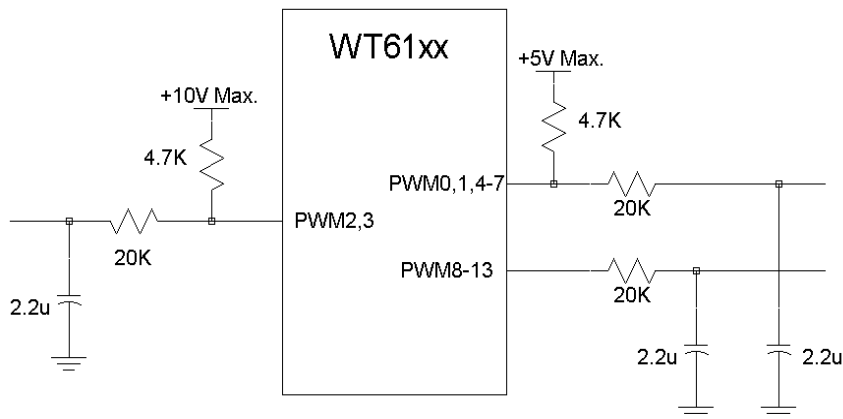

### Hsync, Vsync and DDC Interface Protection

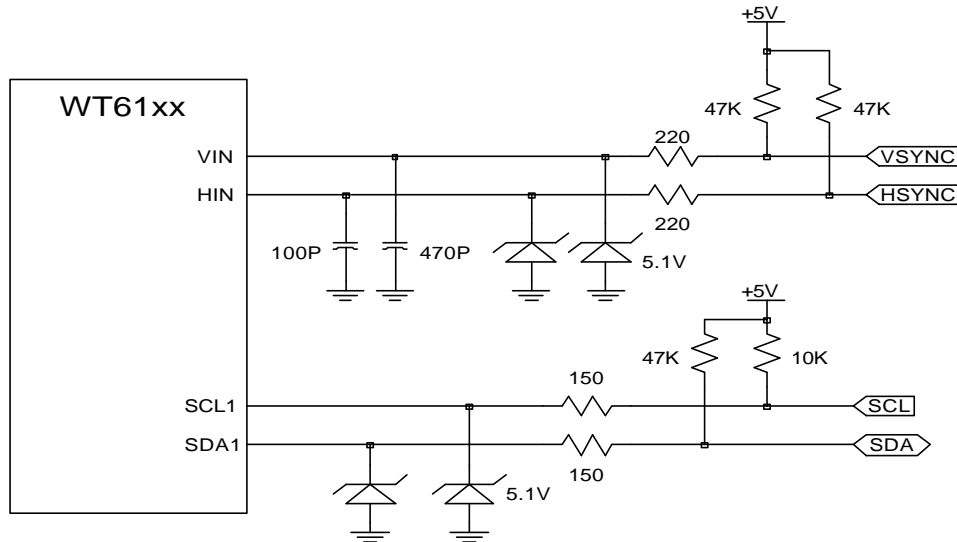

The resistors, capacitors and circuit are reference only.