

TOSHIBA CMOS DIGITAL INTEGRATED CIRCUIT SILICON MONOLITHIC

T M P N 3 1 2 0 B 1 A M

Neuron[®] Chip For Distributed Intelligent Control Networks (LONWORKS[®])

The TMPN3120B1AM is a Neuron Chip which configures LONWORKS nodes on a single chip.

Neuron Chips have all the built-in communications and control functions required to implement LONWORKS nodes.

These nodes may then be easily integrated into highly-reliable distributed intelligent control networks.

The typical functions for this chip are explained below.

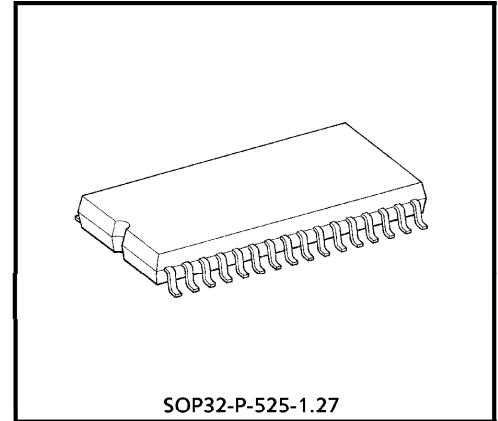

Weight : 1.0g (Typ.)

FEATURES

- I/O Functions
 - Eleven programmable I/O pins.
 - Two programmable 16-bit timers and counters built in.
 - 34 different types of I/O functions to handle a wide range of input and output.
 - ROM firmware image containing pre-programmed I/O drivers, greatly simplifying application programs.
- Network functions
 - Two CPUs for communication protocol processing built in.
The communications and application CPUs execute in parallel.
 - Equipped with a built-in LonTalk protocol which supports all seven levels of the OSI reference model with ISO.
 - The ROM firmware image contains a complete network operating system, greatly simplifying application programs.
 - Built-in twisted-pair wire transceiver
 - Equipped with communications modes and communication speeds which support various types of external transceivers.
Supports twisted-pair wire, power line, radio (RF), infrared, coaxial cables, and fiber optics.
 - Communication port transceiver modes and logical addresses stored within the EEPROM.
Can be amended via the network.

980910EBA1

- TOSHIBA is continually working to improve the quality and the reliability of its products. Nevertheless, semiconductor devices in general can malfunction or fail due to their inherent electrical sensitivity and vulnerability to physical stress. It is the responsibility of the buyer, when utilizing TOSHIBA products, to observe standards of safety, and to avoid situations in which a malfunction or failure of a TOSHIBA product could cause loss of human life, bodily injury or damage to property. In developing your designs, please ensure that TOSHIBA products are used within specified operating ranges as set forth in the most recent products specifications. Also, please keep in mind the precautions and conditions set forth in the TOSHIBA Semiconductor Reliability Handbook.
- The products described in this document are subject to the foreign exchange and foreign trade laws.
- The information contained herein is presented only as a guide for the applications of our products. No responsibility is assumed by TOSHIBA CORPORATION for any infringements of intellectual property or other rights of the third parties which may result from its use. No license is granted by implication or otherwise under any intellectual property or other rights of TOSHIBA CORPORATION or others.
- The information contained herein is subject to change without notice.

- Other functions
 - Application programs are also stored within the EEPROM.
May be updated by downloading over the network. Up to 400-byte applications can be stored.
 - Built-in watch-dog timer.
 - Each chip has a unique ID number.
Effective during the logical installation of networks.
 - Low electrical consumption mode supported with a sleep mode.
 - Built-in low-voltage detection circuit.
Prevents incorrect operations and writing errors in the EEPROM during drops in power voltage.
 - The package is SOP32-P-525-1.27.

BLOCK DIAGRAM

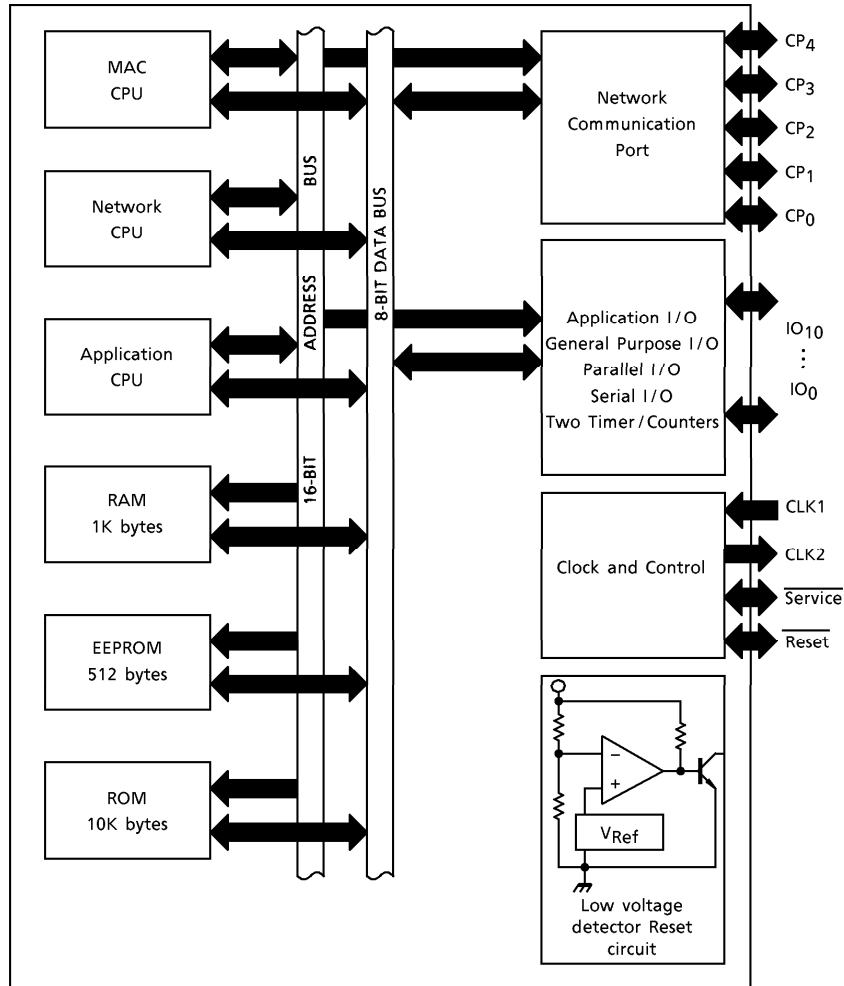

ITEM	TMPN3120B1AM
CPU	8-bit CPU x 3
RAM	1,024 bytes
ROM	10,240 bytes
EEPROM	512 bytes
16-bit Timer / Counter	2 channels
External Memory Interface	Not available
Package	32-pin SOP

PIN ASSIGNMENT

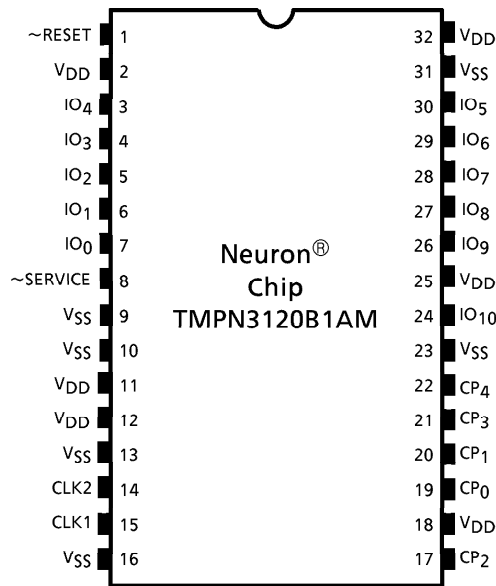

PIN FUNCTION

PIN No.	PIN NAME	I/O	PIN FUNCTION
15	CLK1	Input	Oscillator connection, or external clock input.
14	CLK2	Output	Oscillator connection. Leave open when external clock is input to CLK1.
1	~RESET	I/O (built-in configurable pull-up)	Reset pin. (Active low)
8	~SERVICE	I/O (built-in configurable pull-up)	Service pin. Indicator output during operation.
7~4	IO ₀ ~IO ₃	I/O	Large current sink capacity (20mA). General I/O port.
3, 30~28	IO ₄ ~IO ₇	I/O (built-in configurable pull-up)	General I/O port. One of IO ₄ to IO ₇ can be specified as No.1 timer / counter input. Output signal can be output to IO ₀ . IO ₄ can be used as the No.2 timer / counter input with IO ₁ as output.
27, 26, 24	IO ₈ ~IO ₁₀	I/O	General I/O port. Can be used for serial communication with other device.
2, 11, 12, 18, 25, 32	V _{DD}	Input	Power input (5.0V Typ.)
9, 10, 13, 16, 23, 31	V _{SS}	Input	Power input (0V GND)
19, 20, 17, 21, 22	CP ₀ ~CP ₄	I/O	Bidirectional port for communications. Supports several communications protocols by specifying mode.

- (*)
- The ~SERVICE and IO₄~IO₇ terminals are programmable pull-ups.
 - All V_{DD} terminals must be externally connected.
 - All V_{SS} terminals must be externally connected.

MAXIMUM RATINGS ($V_{SS} = 0V$, V_{SS} typ.)

CHARACTERISTICS	SYMBOL	RATING	UNIT
Power Supply Voltage	V_{DD}	- 0.3~7.0	V
Input Voltage	V_{IN}	- 0.3~ $V_{DD} + 0.3$	V
Power Dissipation	P_D	800	mW
Storage Temperature	T_{stg}	- 65~150	°C

OPERATING CONDITIONS

ITEM	SYMBOL	MIN	TYP.	MAX	UNIT
Operating Voltage	V_{DD}	4.5	5.0	5.5	V
Input Voltage (TTL)	V_{IH}	2.0	—	V_{DD}	V
	V_{IL}	V_{SS}	—	0.8	V
Input Voltage (CMOS)	V_{IH}	$V_{DD} - 0.8$	—	V_{DD}	V
	V_{IL}	V_{SS}	—	0.8	V
Operating Frequency	f_{osc}	0.625	—	10	MHz
Operating Temperature	T_{opr}	- 40	—	85	°C

ELECTRICAL CHARACTERISTICS

DC characteristic ($V_{DD} = 5.0V \pm 10\%$, $V_{SS} = 0V$, $T_a = -40 \sim 85^\circ C$)

(Above operating conditions apply unless otherwise states.)

CHARACTERISTICS	SYMBOL	PINS	TEST CONDITION	MIN	MAX	UNIT	
LOW Output Voltage (1)	V_{OL} (1)	IO ₀ ~IO ₃	$I_{OL} = 20mA$	0	0.8	V	
			$I_{OL} = 10mA$	0	0.4	V	
LOW Output Voltage (2)	V_{OL} (2)	~SERVICE	Duty cycle = 50%	$I_{OL} = 20mA$	0	0.8	V
				$I_{OL} = 10mA$	0	0.4	V
LOW Output Voltage (3)	V_{OL} (3)	CP ₂ , CP ₃	$I_{OL} = 40mA$	0	1.0	V	
LOW Output Voltage (4)	V_{OL} (4)	Others (Note 1)	$I_{OL} = 1.4mA$	0	0.4	V	
HIGH Output Voltage (1)	V_{OH} (1)	IO ₀ ~IO ₃	$I_{OH} = -1.4mA$	$V_{DD} - 0.4$	V_{DD}	V	
HIGH Output Voltage (2)	V_{OH} (2)	~SERVICE	$I_{OH} = -1.4mA$	$V_{DD} - 0.4$	V_{DD}	V	
HIGH Output Voltage (3)	V_{OH} (3)	CP ₂ , CP ₃	$I_{OH} = -40mA$	$V_{DD} - 1.0$	V_{DD}	V	
HIGH Output Voltage (4)	V_{OH} (4)	Others (Note 1)	$I_{OH} = -1.4mA$	$V_{DD} - 0.4$	V_{DD}	V	
Input Current	I_{IN}	(Note 2)	$V_{IN} = V_{SS} \sim V_{DD}$	- 10	+ 10	μA	
Pull-up Current	I_{PU}	IO ₄ ~IO ₇ ~SERVICE, ~RESET (Note 3)	$V_{IN} = 0V$	- 30	- 300	μA	
Low-voltage Detection Level	V_{LVD}	V_{DD}	—	3.8	4.5	V	

(Note 1) Output voltage characteristics exclude the ~RESET pin and CLK2 pin.

(Note 2) Excludes pull-up input pins.

(Note 3) The IO₄ to IO₇ and ~SERVICE pins have programmable pull-ups. ~RESET has a fixed pull-up.

ITEM		SYMBOL	TYP.	MAX	UNIT
Operating Mode Current Consumption	10MHz Clock	I _{DD(OP)}	17	30	mA
	5MHz Clock		9	15	
	2.5MHz Clock		6	8	
	1.25MHz Clock		4	5	
	0.625MHz Clock		2	3	
Sleep Mode Current Consumption		I _{DD(SLP)}	16	100	μA

(Note) Test conditions for current dissipation

V_{DD} = 5V, all output = with no load, all input = 0.2V or below or V_{DD} - 0.2V, programmable pull-up = off, crystal oscillator clock input, differential receiver disabled.

The current value (typ.) is a typical value when Ta = 25°C.

The current value (max) applies to the rated temperature range of V_{DD} = 5.5V.

200μA (typ.) to 600μA (max) is added to the current of the differential receiver when the receiver is enabled.

The differential receiver is enabled by either of the following conditions :

- When the Neuron chip is in Run mode and the communication ports are in Differential mode.
- When the Neuron chip is in Sleep mode, the communication ports are in Differential mode, and the Wakeup pins are masked.

- Echelon, Neuron, LON, LonTalk, LonBuilder, NodeBuilder, LONWORKS, 3150, 3120 and LonManager are the registered trade marks of Echelon Corporation, USA.
- The Neuron Chip is manufactured by Toshiba under license from America's Echelon Inc. A licensing agreement between the customer and Echelon Corporation, USA must be concluded before purchasing any of the neuron chip products.
- This IC (TMPN3120B1AM) is covered by the patent agreement between Toshiba and Bull Cp8 Inc. Kindly understand that this product cannot be used in IC cards or other portable devices (refer to the definition below).

“PORTABLE DEVICES”

(I) A portable device defined by ISO standard 7816 as having a width or length of ± 10 mm and a thickness of ± 3 mm.

(II) A portable device that conforms to the electrical connection placement and shape stipulated by ISO standard 7816 Part 2.

(III) A pocket-sized portable device in which the ID or history of the holder or the ID or history of the device can be stored as information.

[BULL CP8 patent: America patent number 4,382,279]

- The following patent notice has been issued by Echelon Corporation, USA in relation to the use of the I²C I /O object.

PATENT NOTICE

Echelon's delivery to you of the "I²C Library" does not convey nor imply a right under any I²C patent rights of Philips Electronics N.V. ("Philips") to make, use or sell any product employing such patent rights. Please refer all questions with respect to I²C patents and licenses to Philips at:

Mr. H.B. Schoonheijm
Corporate Patents and Trademarks
Philips International B.V.
P.O. Box 220
5600 MD Eindhoven
The Netherlands

Telephone + 31 40 743479

Facsimile + 31 40 743489

PACKAGE DIMENSIONS
SOP32-P-525-1.27

Unit : mm

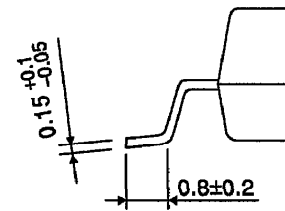
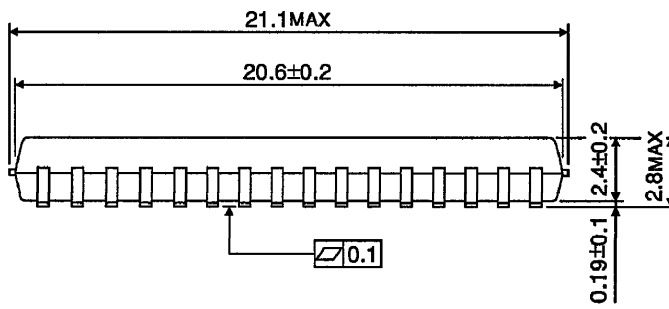
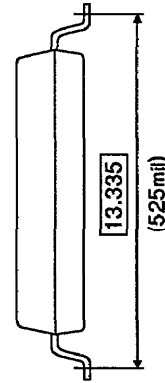
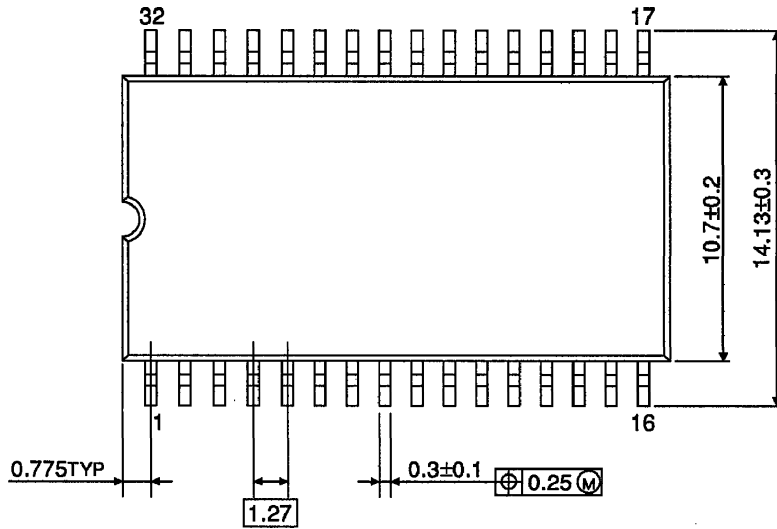

Weight : 1.0g (Typ.)