

Quartz Crystal Oscillator IC with Selectable Divider

■GENERAL DESCRIPTION

The NJU6311 is a fundamental quartz crystal oscillator, up to 50MHz.

The oscillation amplifier incorporates feedback resistor and capacitors (Cg, Cd), therefore, it requires no external component except quartz crystal, and realizes very low standby current with NAND circuit.

The output frequency select 6-stage to use selectable switch IN1, IN2, and IN3, divided output are f_0 , $f_0/2$, $f_0/4$, $f_0/8$, $f_0/16$ and $f_0/32$.

The drivability of the 3-state output buffer is 16mA@5V, thus it can drive C-MOS load.

Furthermore, the package is Thin-VSP10.

■PACKAGE OUTLINE



NJU6311C-D



NJU6311RB2

■FEATURES

- Operating Voltage 2.0 to 5.5V
- Maximum Oscillation Frequency 50MHz
- Low Operating Current
- High Fan-out
 - $I_{OH}/I_{OL}=6mA @2.5V$
 - $I_{OH}/I_{OL}=8mA @3.3V$
 - $I_{OH}/I_{OL}=16mA @5.0V$
- Selectable Divider $f_0, f_0/2, f_0/4, f_0/8, f_0/16$ and $f_0/32$
- Oscillation Stop and Output Stand-by Function
- 3-State Output Buffer
- Oscillation Capacitors Cg and Cd on-chip
- Package Outline Thin-Chip/TVSP-10
- C-MOS Technology

■PAD LOCATION

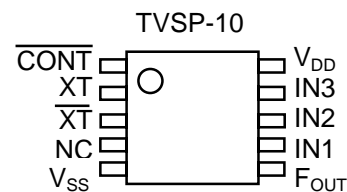
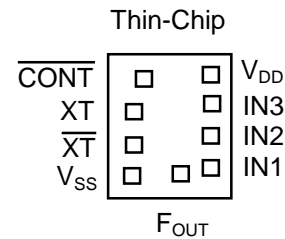

■SELECTABLE DIVIDER LOGIC

IN1	IN2	IN3	F _{OUT}
H	H	H	f_0
L	H	H	$f_0/2$
H	L	H	$f_0/4$
L	L	H	$f_0/8$
H	H	L	$f_0/16$
L	H	L	$f_0/32$
H	L	L	
L	L	L	

■COORDINATES

No	Pad Name	X	Y
1	CONT	-123	325
2	XT	-200	105
3	XT	-200	-130
4	V _{SS}	-221	-346
5	F _{OUT}	57	-325
6	IN1	221	-295
7	IN2	221	-60
8	IN3	221	160
9	V _{DD}	221	346

Starting Point:Chip Center Unit[um]
 Chip Size:0.7x0.95mm
 Thin-Chip Thickness (-D):200±20um
 Pad Size:90x90um

■BLOCK DIAGRAM

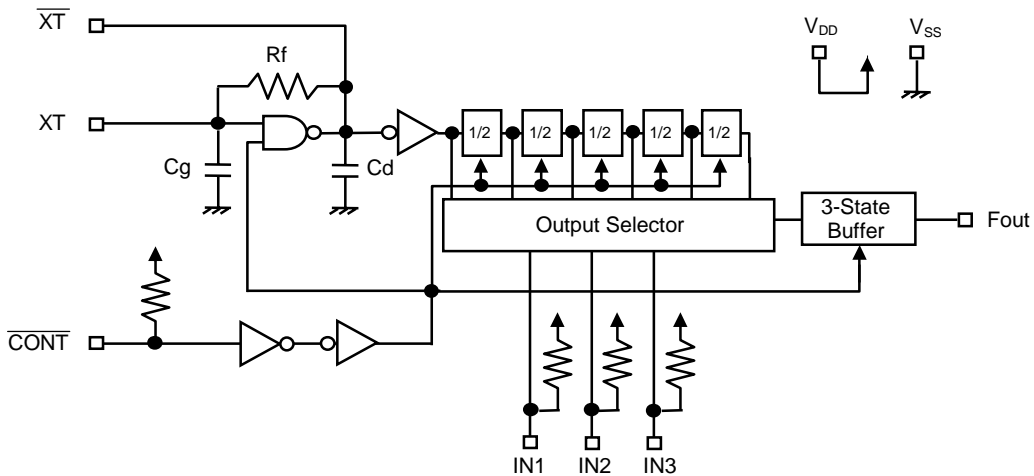

■TERMINAL DESCRIPTION

SYMBOL	FUNCTION				
CONT	Oscillation and 3-state Output Buffer Control				
	CONT	F _{OUT}			
	H or OPEN	Frequency Output corresponding to Selectable Divider			
	L	Oscillation Stop and High impedance Output			
XT XT	Quartz Crystal Connecting Terminals				
V _{SS}	V _{SS} =0V				
F _{OUT}	Frequency Output				
IN1 IN2 IN3	Selectable Divider				
		IN1	IN2	IN3	F _{OUT}
		H	H	H	f ₀
		L	H	H	f ₀ /2
		H	L	H	f ₀ /4
		L	L	H	f ₀ /8
		H	H	L	f ₀ /16
		L	H	L	f ₀ /32
	H	L	L		
	"H" or OPEN				
V _{DD}	V _{DD} =2.5/3.3V/5.0V				

■ABSOLUTE MAXIMUM RATINGS

(Ta=25°C)

PARAMETER	SYMBOL	RATING	UNIT
Supply Voltage	V _{DD}	-0.5 to +7.0	V
Input Voltage	V _{IN}	V _{SS} -0.5 to V _{DD} +0.5	V
Output Voltage	V _O	-0.5 to V _{DD} +0.5	V
Input Current	I _{IN}	±10	mA
Output Current	I _O	±25	mA
Power Dissipation	P _D	320 (TVSP-10)	mW
Operating Temperature Range	T _{opr}	-40 to +85	°C
Storage Temperature Range	T _{stg}	-55 to +125	°C

Note1) If the supply voltage(V_{DD}) is less than 7.0V, the input voltage must not over the V_{DD} level though 7.0V is limit specified.

Note2) Decoupling capacitor should be connected between V_{DD} and V_{SS} due to the stabilized operation for the circuit.

Note3) The power dissipation is the maximum value at only the package.

■ELECTRICAL CHARACTERISTICS

(Ta=25°C)

PARAMETER	SYMBOL	CONDITIONS	MIN	TYP	MAX	UNIT
Operating Voltage	V _{DD}		2.0		5.5	V

(V_{DD}=2.5V, Ta=25°C)

PARAMETER	SYMBOL	CONDITIONS	MIN	TYP	MAX	UNIT
Operating Current	I _{DD}	fosc=16MHz, C _L =15pF			6	mA
Oscillation Stopping Current	I _{STB}	CONT=IN1=IN2=IN3=V _{SS} , No load		4	10	uA
Stand-by Current	I _{st}	CONT=XT=V _{SS} , No load Note4)			1	uA
Input Voltage	V _{IH}	CONT, IN1, IN2, IN3	1.75		2.5	V
	V _{IL}	CONT, IN1, IN2, IN3	0		0.75	V
Output Current	I _{OH}	V _{OH} =2.25V	6			mA
	I _{OL}	V _{OL} =0.25V	6			mA
Input Current	I _{IN}	CONT= IN1=IN2=IN3=0.8V _{DD}		7.5	12.0	uA
		CONT= IN1=IN2=IN3=0.2V _{DD}		1.2	2.0	uA
3-state Off Leakage Current	I _{OZ}	CONT=V _{SS} , F _{OUT} = V _{DD} or V _{SS}			±0.1	uA
Feedback Resistance	R _f			255		kΩ
Internal Capacitor	C _g /C _d	fosc=16MHz		15/15		pF
Maximum Oscillation Frequency	F _{MAX}		50			MHz
Output Signal Symmetry	SYM	C _L =15pF, @V _{DD} /2	45	50	55	%
		C _L =30pF, @V _{DD} /2	40	50	60	
Output Signal Rise Time	tr	C _L =15pF, 10% to 90%		2	4	ns
		C _L =30pF, 10% to 90%		4	8	
Output Signal Fall Time	tf	C _L =15pF, 90% to 10%		2	4	ns
		C _L =30pF, 90% to 10%		4	8	
Output Disable time	T _{PLZ}	C _L =15pF, R _{UP} =10kΩ			200	ns
Output Enable Time	T _{PZL}	C _L =15pF, R _{UP} =10kΩ			200	ns

Note4) Excluding input current on CONT Terminal.

(V_{DD}=3.3V, T_a=25°C)

PARAMETER	SYMBOL	CONDITIONS	MIN	TYP	MAX	UNIT
Operating Current	I _{DD}	fosc=16MHz, C _L =30pF			8	mA
Oscillation Stopping Current	I _{STB}	CONT=IN1=IN2=IN3=V _{SS} , No load		8	20	uA
Stand-by Current	I _{st}	CONT=XT=V _{SS} , No load Note4)			1	uA
Input Voltage	V _{IH}	CONT, IN1, IN2, IN3	2.31		3.3	V
	V _{IL}	CONT, IN1, IN2, IN3	0		0.99	V
Output Current	I _{OH}	V _{OH} =2.97V	8			mA
	I _{OL}	V _{OL} =0.33V	8			mA
Input Current	I _{IN}	CONT= IN1=IN2=IN3=0.8V _{DD}		10.0	15.0	uA
		CONT= IN1=IN2=IN3=0.2V _{DD}		1.8	3.0	uA
3-state Off Leakage Current	I _{OZ}	CONT=V _{SS} , F _{OUT} = V _{DD} or V _{SS}			±0.1	uA
Feedback Resistance	R _f			255		kΩ
Internal Capacitor	C _g /C _d	fosc=16MHz		15/15		pF
Maximum Oscillation Frequency	F _{MAX}		50			MHz
Output Signal Symmetry	SYM	C _L =15pF, @V _{DD} /2	45	50	55	%
		C _L =30pF, @V _{DD} /2	45	50	55	
Output Signal Rise Time	tr	C _L =15pF, 10% to 90%		2	4	ns
		C _L =30pF, 10% to 90%		4	8	
Output Signal Fall Time	tf	C _L =15pF, 90% to 10%		2	4	ns
		C _L =30pF, 90% to 10%		4	8	
Output Disable time	T _{PLZ}	C _L =15pF, R _{UP} =10kΩ			150	ns
Output Enable Time	T _{PZL}	C _L =15pF, R _{UP} =10kΩ			150	ns

Note4) Excluding input current on CONT Terminal.

(V_{DD}=5.0V, T_a=25°C)

PARAMETER	SYMBOL	CONDITIONS	MIN	TYP	MAX	UNIT
Operating Current	I _{DD}	fosc=16MHz, C _L =50pF			15	mA
Oscillation Stopping Current	I _{STB}	CONT=IN1=IN2=IN3=V _{SS} , No load		20	40	uA
Stand-by Current	I _{st}	CONT=XT=V _{SS} , No load Note4)			1	uA
Input Voltage	V _{IH}	CONT, IN1, IN2, IN3	3.5		5.0	V
	V _{IL}	CONT, IN1, IN2, IN3	0		1.5	V
Output Current	I _{OH}	V _{OH} =2.97V	16			mA
	I _{OL}	V _{OL} =0.33V	16			mA
Input Current	I _{IN}	CONT= IN1=IN2=IN3=0.8V _{DD}		27.0	40.0	uA
		CONT= IN1=IN2=IN3=0.2V _{DD}		5.5	8.0	uA
3-state Off Leakage Current	I _{OZ}	CONT=V _{SS} , F _{OUT} = V _{DD} or V _{SS}			±0.1	uA
Feedback Resistance	R _f			255		kΩ
Internal Capacitor	C _g /C _d	fosc=16MHz		15/15		pF
Maximum Oscillation Frequency	F _{MAX}		50			MHz
Output Signal Symmetry	SYM	C _L =15pF, @V _{DD} /2	45	50	55	%
		C _L =50pF, @V _{DD} /2	45	50	55	
Output Signal Rise Time	tr	C _L =15pF, 10% to 90%		2	4	ns
		C _L =50pF, 10% to 90%		4	8	
Output Signal Fall Time	tf	C _L =15pF, 90% to 10%		2	4	ns
		C _L =50pF, 90% to 10%		4	8	
Output Disable time	T _{PLZ}	C _L =15pF, R _{UP} =10kΩ			100	ns
Output Enable Time	T _{PZL}	C _L =15pF, R _{UP} =10kΩ			100	ns

Note4) Excluding input current on CONT Terminal.

MEASUREMENT CIRCUITS

(1) Output Signal Symmetry

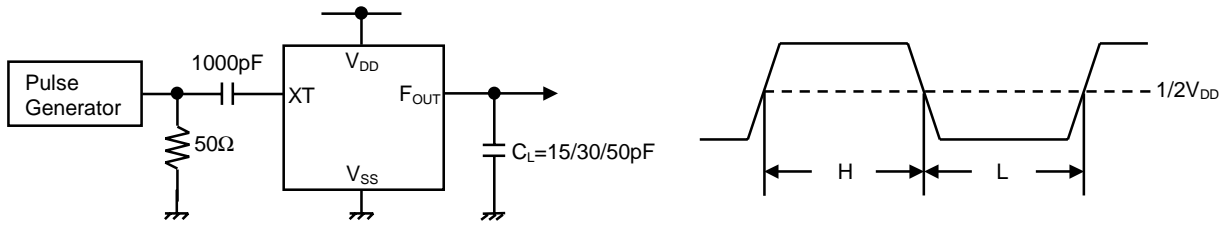

(2) Output Signal Rise/Fall Time

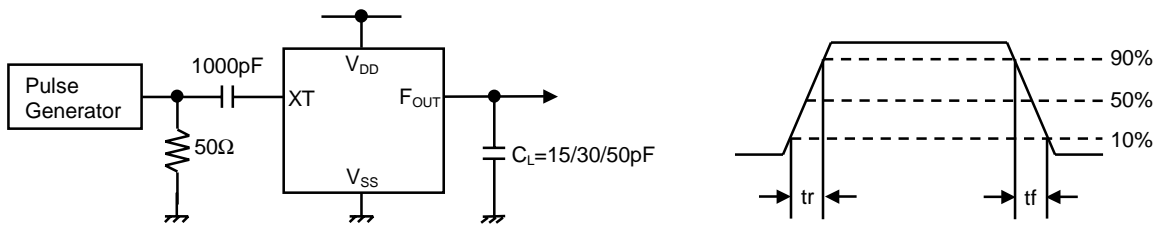

(3) Output Disable/Enable Time

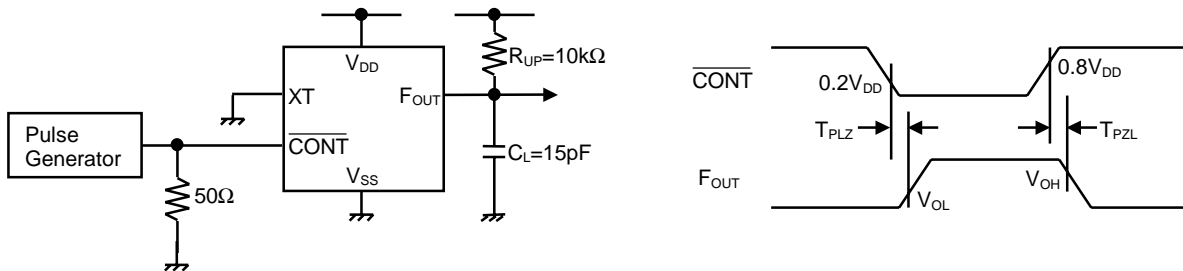

[CAUTION]
 The specifications on this data book are only given for information, without any guarantee as regards either mistakes or omissions. The application circuits in this data book are described only to show representative usages of the product and not intended for the guarantee or permission of any right including the industrial rights.