

## Features

- High Reliability
- Low Loss
- Operation Through 26 GHz
- Wide Temperature Operation

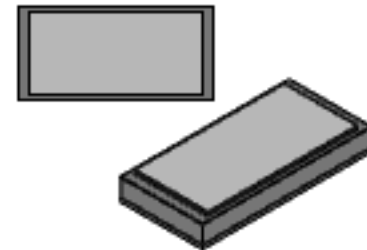

## Description

The FET Chip Mounting Capacitor is an MIS thin film device which features small size and very high Q making it ideal for hybrid microelectronic applications at microwave frequencies.

The device has a dielectric composed of thermally grown silicon dioxide over which a layer of silicon nitride is deposited. This dielectric possesses a low temperature coefficient of capacitance, very high insulation resistance (typically greater than  $10^{12}$  ohms), and low dissipation factor. The device also exhibits excellent long term stability making it suitable for high reliability applications. The capacitor has a high dielectric breakdown which permits the use of thin dielectrics resulting in large capacitance in a small area.

The plated gold metalization on the top face of the chip extends over most of the top surface. Gold wire can be readily thermocompression bonded to this metalization. The back side of the chip is also gold metallized and is readily solderable. Custom parts can be made having special values of capacitance or working voltage. Special metallization geometries or chip sizes can also be made available upon request.

## Maximum Ratings

Operating Temperature ( $T_{OP}$ ):	-65 to + 200°C
Storage Temperature ( $T_{STG}$ ):	-65 to +200°C
Dielectric Withstanding Voltage:	50 Volts

## Electrical Specifications

Capacitance Range .....	100 pF
Temperature Coefficient .....	50 ppm/°C
Capacitance Tolerance .....	±20%
Thermal Resistance	
SC9016 .....	10°C/W
SC9017 .....	12°C/W

Part Number	Outline Drawing Number	Thickness	For FET Chip Thickness	For Alumina Substrate Thickness
SC9016-000	411-801	0.010	0.005	0.015
SC9017-000	411-802	0.020	0.005	0.025

The capacitor is designed to serve as a carrier for FET amplifier chips. As shown in Figure 1, when the FET chip is mounted directly onto the top metal pad of the capacitor, the gate and drain pads are on the same level as the top of the alumina circuit. Therefore, short wire lengths can be used to minimize the lead inductance. The SC9016 is a 10 mil thick chip designed for 15 mil thick alumina, while the SC9017 is a 20 mil thick chip designed for 26 mil thick alumina. When the FET chips is mounted directly onto the top metal pad of the capacitor, the source pads on the FET chip can be wire bonded to the same metal pads, which accomplishes RF bypass to ground via the capacitor.

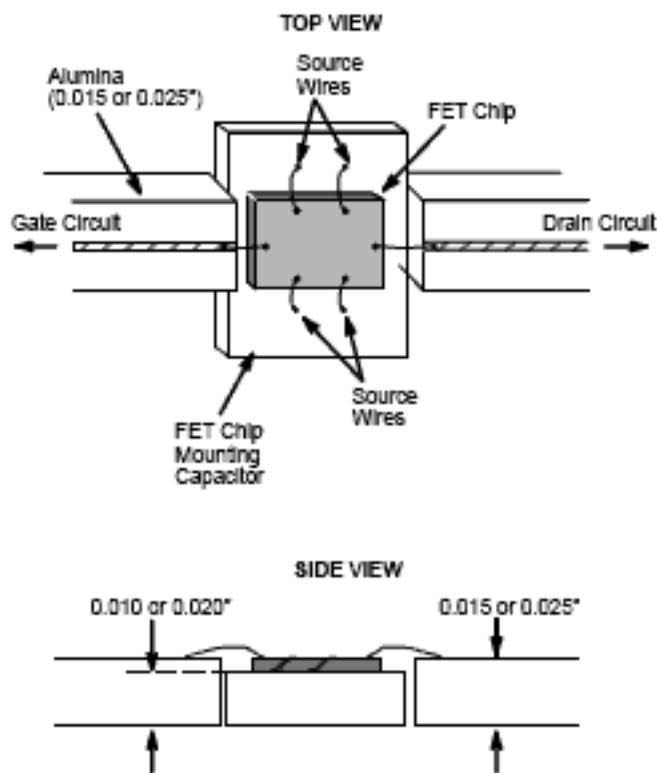

Figure 1. FET Chip Mounted on Top Metal Pad of Capacitor

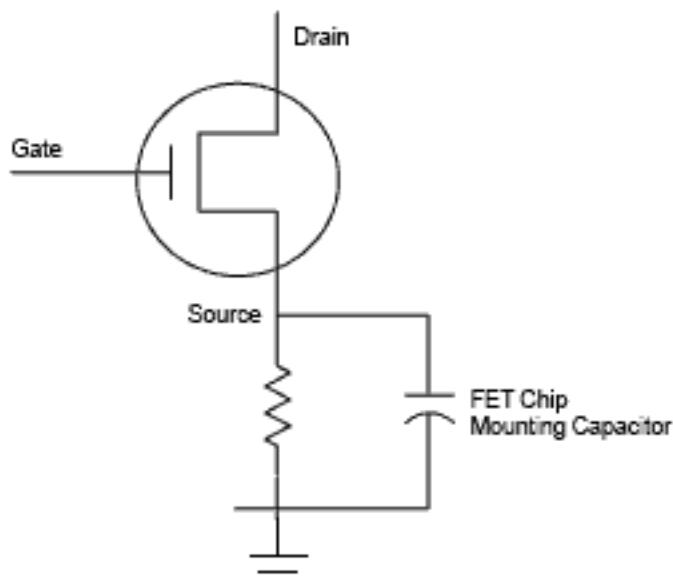
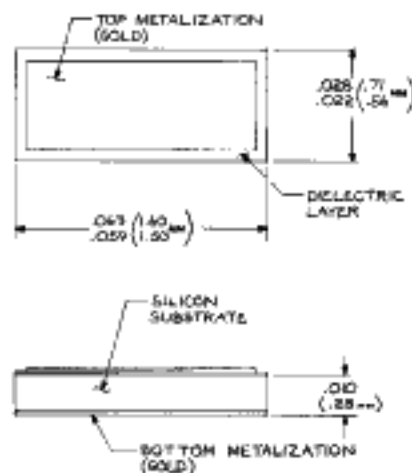

Figure 2. Schematic Diagram

### Outline Dimensions

411-801



411-802

