

DESCRIPTION

The M51489L is a semiconductor integrated circuit designed as video AGC for video equipment applications.

FEATURES

- Keyed/Peak AGC circuit employed
(Usually, this circuit functions as keyed AGC keeping the amplitude of sync signals constant. If the overall amplitude becomes excessively large, as in case of short sync signals, the circuit automatically operates as peak AGC and forces the output amplitude of video signals constant.)
- Two video signal inputs provided, with a self-contained selector circuit
- Sync separator self-contained
- ZIL package employed, permitting high density mounting requiring only a small area on printed circuit board

APPLICATION

VCR and other video equipment

RECOMMENDED OPERATING CONDITION

Supply voltage range11-12.5 V
 Rated supply voltage12 V

PIN CONFIGURATION

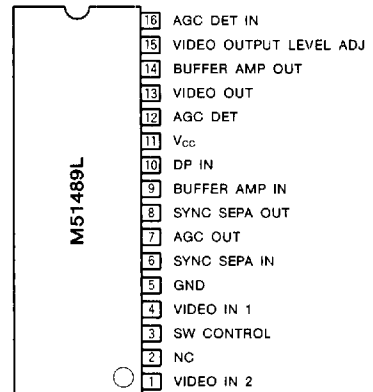

Outline 16P5A

NC: No connection

BLOCK DIAGRAM

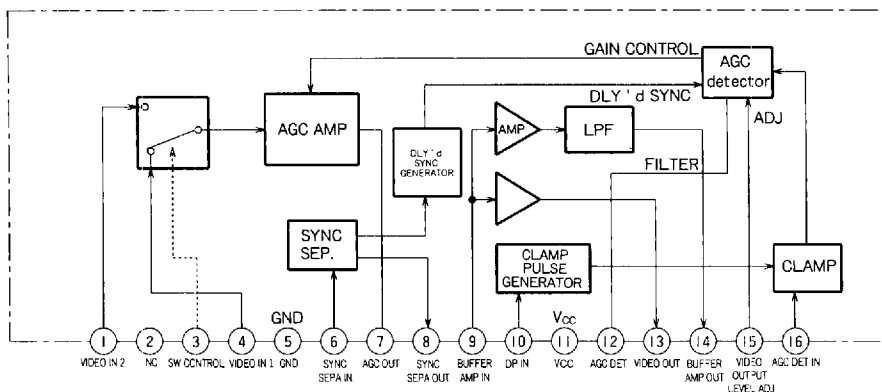

ABSOLUTE MAXIMUM RATINGS

Symbol	Parameter	Ratings	Unit
V _{CC} MAX	Supply voltage	13	V
P _d MAX	Power dissipation	800	mW
T _{opr}	Operating temperature	-20~75	°C
T _{stg}	Storage temperature	-40~125	°C
K _θ	Thermal derating	8	mW/deg.

ELECTRICAL CHARACTERISTICS (T_a=25°C, unless otherwise noted)

Symbol	Parameter		Test conditions	Limits			Unit
				Min.	Typ.	Max.	
I _{cc}	Circuit current		Inflow current at pin 11	12	17	22	mA
V _{oa}	VIDEO output level	a	Input 1 : 1V _{PP} video signal When V ₁₅ =6.2V, S ₁ =B, S ₂ =C	0.8	1.0	1.2	V _{PP}
V _{ob}		b	Input 2 : 1V _{PP} video signal When V ₁₅ =6.2V, S ₂ =B				V _{PP}
AGC+	AGC characteristics	a	Input 2 : 2V _{PP} video signal S ₂ =B	-1.0	0.2	1.0	dB
AGC-		b	Input 2 : 0.5V _{PP} video signal S ₂ =B	-1.0	-0.2	1.0	dB
FCa	AGC AMP frequency characteristics	a	Input 1 : 5MHz sine wave S ₁ =B, S ₂ =C, S ₄ =B Attenuation from the standard input amplitude of 0.5V _{PP} at 100kHz	-2.0	-1.1	-	dB
FCb		b	Input 2 : 5MHz sine wave S ₂ =B, S ₄ =B Attenuation from the standard input amplitude of 0.5V _{PP} at 100kHz				dB
FCc	LPF frequency characteristics	Pin 14 output : 5MHz sine wave S ₂ =B, S ₄ =B Attenuation from the standard input amplitude of 0.5V _{PP} at 100kHz		-18	-13	-8	dB
CTa	VIDEO SW crosstalk	a	Input 2 : 1MHz sine wave S ₂ =B/C, S ₄ =B	-	-60	-50	dB
CTb		b	Input 1 : 1MHz sine wave S ₁ =B, S ₂ =C/B, S ₄ =B				dB
V _{TH}	SW threshold level			0.7	1.2	2.0	V
V _{SH}	Sync separation pulse	Hi voltage		10	11	-	V
V _{SL}		Lo voltage		-	0	0.1	V
T _S		Pulse width		3.9	4.3	4.7	μs

Unless otherwise noted, SWs shall be set to A.

TEST CIRCUIT

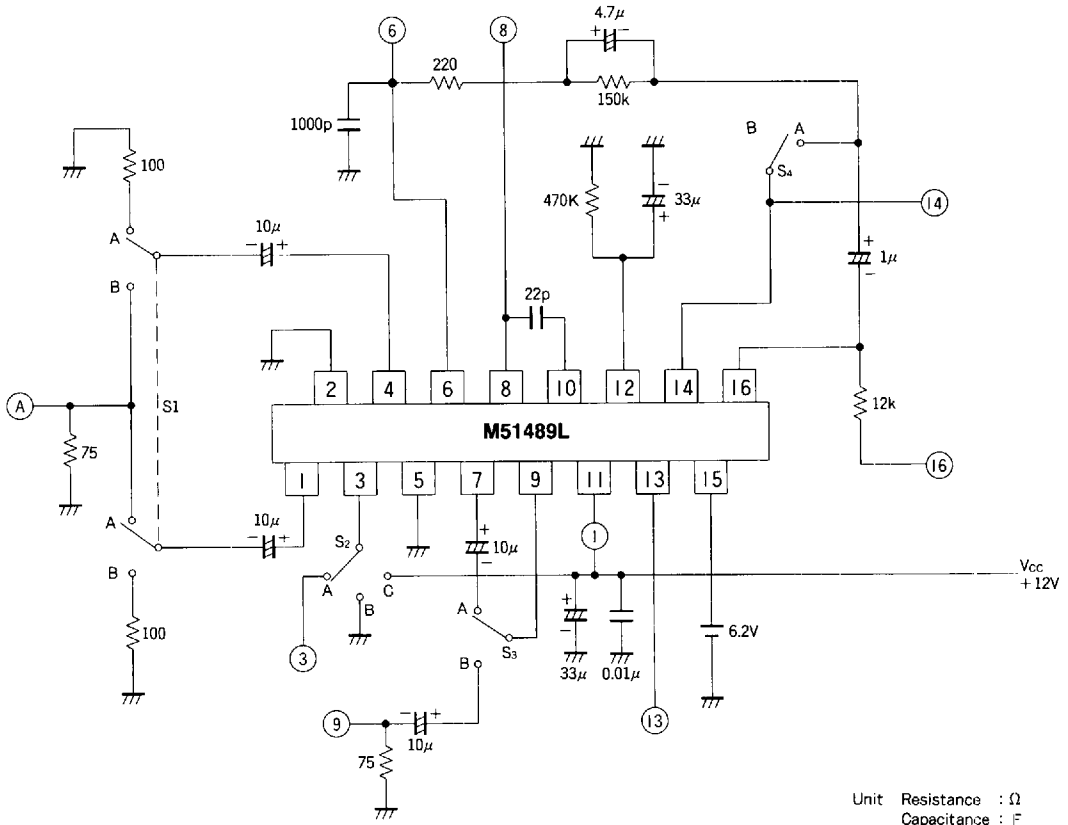

Unit Resistance : Ω
Capacitance : F

TYPICAL CHARACTERISTICS

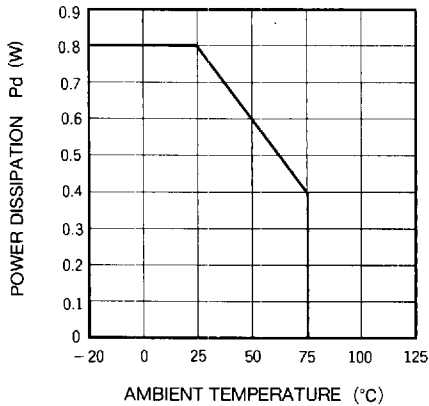

THERMAL DERATING (MAXIMUM RATING)



DESCRIPTION OF PIN

Pin No.	Symbol	Function	DC Voltage (V)	Peripheral circuit of pins
①	VIDEO IN 2	Input video signal ② (Input impedance $\approx 22K\Omega$) (Synchronizing by trailing edge)	5.9V	
②	N. C.	—	—	—
③	SW CONTROL	Video input switching ($V_{TH} \approx 1.2V$)	—	
④	VIDEO IN 1	Input video signal ① (Input impedance $\approx 22K\Omega$) (Synchronizing by trailing edge)	5.9V	
⑤	GND	Grounding	0V	—
⑥	SYNC SEPA IN	Sync separation circuit Signal input (Synchronizing by trailing edge)	9.8V	

DESCRIPTION OF PIN (cont.)

Pin No.	Symbol	Function	DC Voltage (V)	Peripheral circuit of pins
⑦	AGC OUT	Video AGC Gain control amp (Emitter-follower output) (Output amplitude $\approx 0.5V_{PP}$, synchronizing by trailing edge)	10.2V	
⑧	SYNC SEPA OUT	Sync separator output (Sync [H] )	0/11V	
⑨	BUFFER AMP IN	Buffer amp input (Input impedance = 10KΩ) (Input amplitude $\approx 0.5V_{PP}$, synchronizing by trailing edge)	4.1V	
⑩	DP IN	Differential pulse input (Differential pulse of sync signal)  For clamp pulse generation	3.5V	
⑪	Vcc	Power supply	12V	—
⑫	AGC DET	AGC filter (AGC detector voltage holding pin)	6.2V	

DESCRIPTION OF PIN (cont.)

Pin No.	Symbol	Function	DC Voltage (V)	Peripheral circuit of pins
13	VIDEO OUT	Video output (Emitter-follower) Output amplitude $\approx 1V_{p-p}$ Synchronizing by trailing edge	9.2V	
14	BUFFER AMP OUT	Buffer amp output (Emitter-follower) Output amplitude $\approx 2V_{p-p}$ Synchronizing by trailing edge	6.5V	
15	VIDEO OUT LEVEL ADJ.	AGC level adjustment	6V	
16	AGC DET IN	AGC detector input Clamp input Input amplitude $\approx 2V_{p-p}$ Synchronizing by falling edge	4V	