



MIC68200

2A Sequencing LDO with Tracking and Ramp Control™

General Description

The MIC68200 is a high peak current LDO regulator designed specifically for powering applications such as FPGA core voltages that require high start up current with lower nominal operating current. Capable of sourcing 2A of current for start-up, the MIC68200 provides high power from a small MLF™ leadless package. The MIC68200 can also implement a variety of power-up and power-down protocols such as sequencing, tracking, and ratiometric tracking.

The MIC68200 operates from a wide input range of 1.65V to 5.5V, which includes all of the main supply voltages commonly available today. It is designed to drive digital circuits requiring low voltage at high currents (i.e. PLDs, DSP, microcontroller, etc.). The MIC68200 incorporates a delay pin (Delay) for control of power on reset output (POR) at turn-on and power-down delay at turn-off. In addition, there is a ramp control pin (RC) for either tracking applications or output voltage slew rate adjustment at turn-on and turn-off. This is important in applications where the load is highly capacitive and in-rush currents can cause supply voltages to fail and microprocessors or other complex logic chips to hang up.

Multiple MIC68200s can be daisy chained in two modes. In tracking mode the output voltage of the Master drives the RC pin of a Slave so that the Slave tracks the main regulator during turn-on and turn-off. In sequencing mode the POR of the Master drives the enable (EN) of the Slave so that it turns on after the Master and turns off before (or after) the Master. This behavior is critical for power-up and power-down control in multi-output power supplies. The MIC68200 is fully protected offering both thermal and current limit protection and reverse current protection.

The MIC68200 has a junction temperature range of -40°C to +125°C and is available in fixed as well as an adjustable option. There is also an adjustable option. The MIC68200 is offered in the tiny 10-pin 3mm x 3mm MLF™ package.

Features

- Stable with 4.7uF ceramic capacitor
- Input voltage range: 1.65V to 5.5V
- ±1.0% initial output tolerance
- 2A maximum output current – peak start up
- 1A Continuous Operating Current
- **Tracking on turn-on and turn-off with pin strapping**
- **Timing Controlled Sequencing On/Off**
- **Programmable Ramp Control™ for in-rush current limiting and slew rate control of the output voltage**
- Power-on Reset (POR) supervisor with programmable delay time
- **Single Master can control multiple Slave regulators with tracking output voltages**
- **Tiny 3mm x 3mm MLF™ package**
- Maximum dropout ($V_{IN} - V_{OUT}$) of 500mV over temperature at 1A output current
- Fixed and Adjustable Output Voltages
- Excellent line and load regulation specifications
- Logic controlled shutdown
- Thermal shutdown and current limit protection

Applications

- FPGA/PLD Power Supply
- Networking/Telecom Equipment
- Microprocessor Core Voltage
- High Efficiency Linear Post Regulator
- Sequenced or Tracked Power Supply

MLF and MicroLeadFrame are trademarks of Amkor Technology, Inc.

Micrel Inc. • 2180 Fortune Drive • San Jose, CA 95131 • USA • tel +1 (408) 944-0800 • fax + 1 (408) 474-1000 • <http://www.micrel.com>

Typical Application

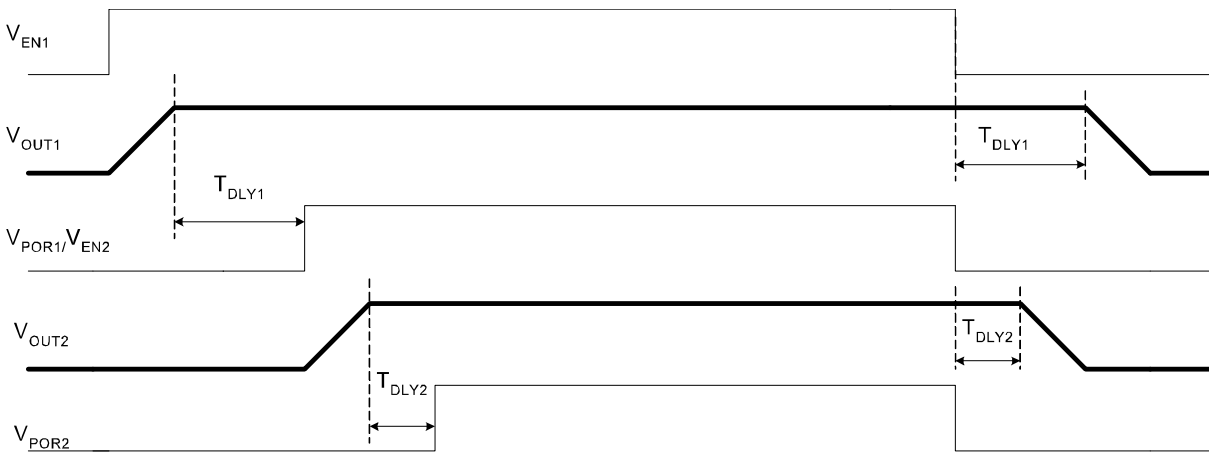
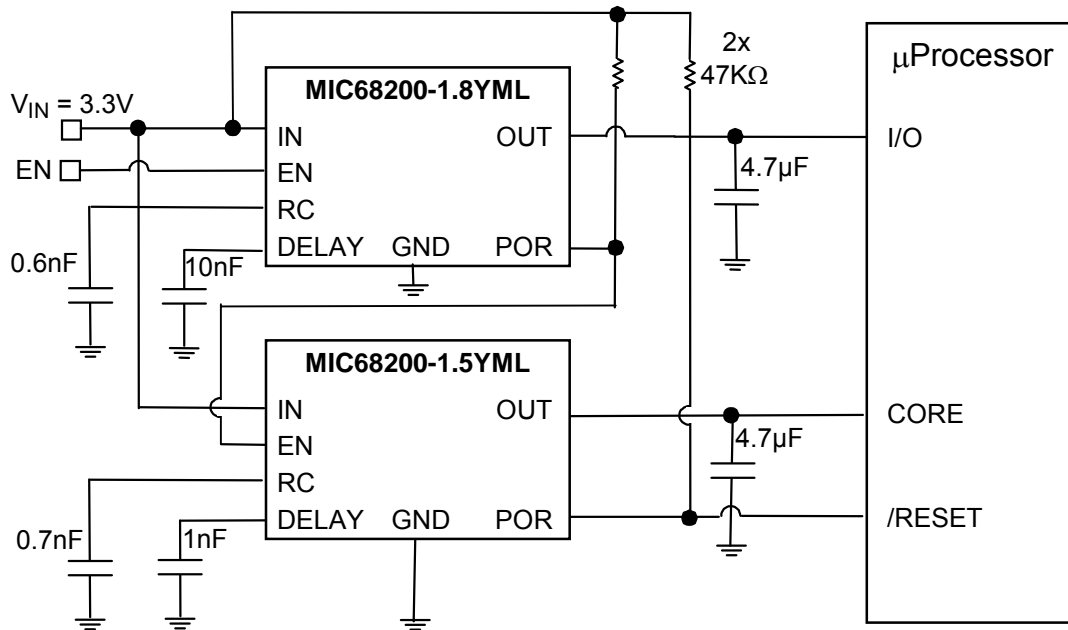

Sequenced Dual Power Supply for I/O and Core Voltage of μ Processor

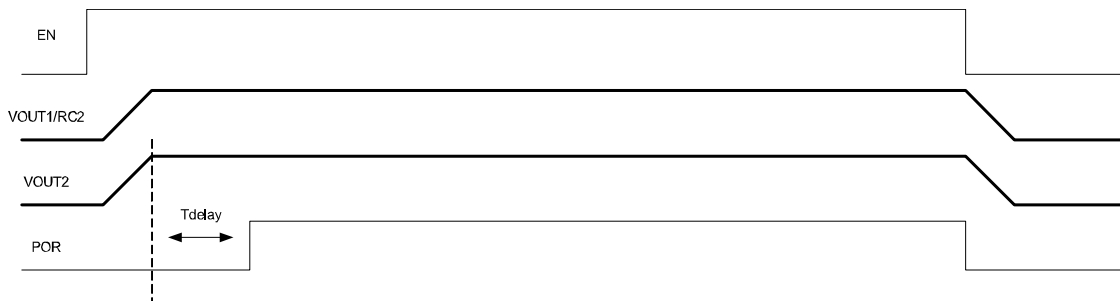
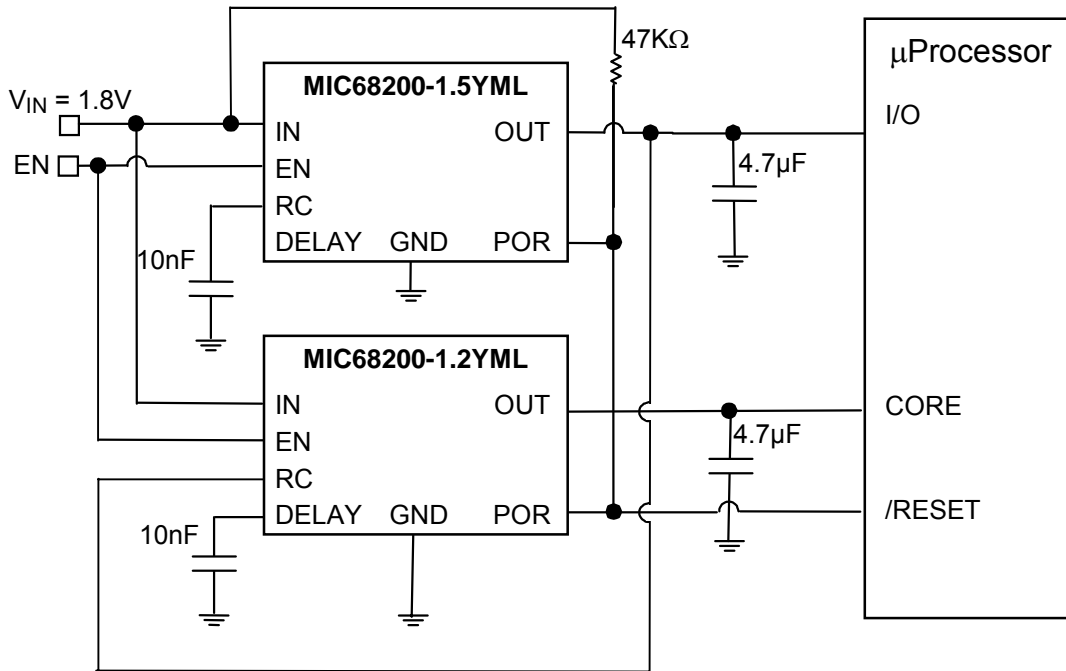

Tracking Dual Power Supply for I/O and Core Voltage of μ Processor

Block Diagram

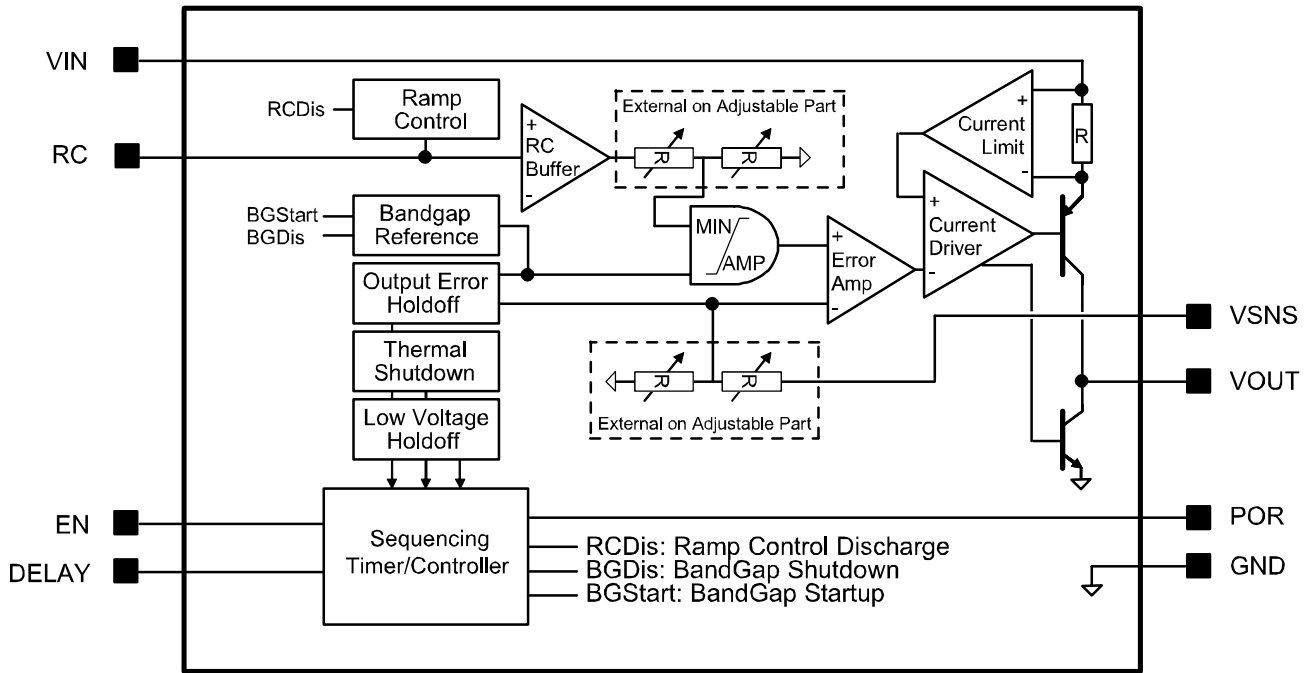

Ordering Information

Part Number	Output Current	Voltage	Junction Temperature Range	Package
MIC68200-1.8YML	2.0A	1.8V	-40°C to +125°C	PB-Free 10-Pin 3x3 MLF™
MIC68200YML	2.0A	ADJ	-40°C to +125°C	PB-Free 10-Pin 3x3 MLF™

NOTE: For additional voltage options, please contact Micrel Marketing.

Pin Configuration

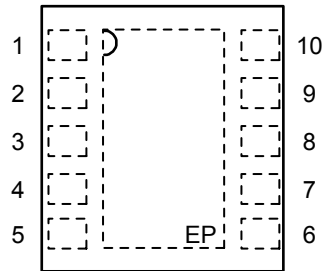

10-Pin 3mm x 3mm MLF (ML)
MIC68200-x.xYML (Fixed)
MIC68200YML (Adjustable)

Pin Description (Pin Numbering may change depending upon layout considerations)

3x3 MLF-10 Fixed	3x3 MLF-10 Adjustable	Pin Name	Pin Function
1,2	1,2	VIN	Input: Input voltage supply pin. Place a capacitor to ground to bypass the input supply
3	3	Delay	Delay: Capacitor to ground sets internal delay timer. Timer delays power-on reset (POR) output at turn-on and ramp down at turn-off.
4	4	RC	Ramp Control: Voltage driven for tracking applications. Capacitor to ground sets slew rate during start-up.
5	5	EN	Enable (Input): CMOS compatible input. Logic high = enable and logic low = shutdown.
6, EP	6, EP	GND	Ground: EP is connected to ground on 3x3 MLF-10L.
7	7	POR	Power-on Reset: Open-drain output device indicates when the output is in regulation. High (open) means device is regulating within 10%. POR onset can be delayed using a single capacitor from Delay-to-ground.
8	8	ADJ / SNS	Adjustable regulators: Feedback input. Connect to external resistor voltage divider. Fixed regulators: Sense pin. Connect to output at load for point-of-load regulation.
9, 10	9,10	VOUT	Output Voltage: Output of voltage regulator. Place capacitor to ground to bypass the output voltage. Minimum load current is 100uA. Nominal bypass capacitor is 4.7uf ceramic.

Absolute Maximum Ratings⁽¹⁾

Supply Voltage (V_{IN}).....	6V
Enable Input Voltage (V_{EN}).....	0 to $V_{IN} + 0.3V$
POR (V_{POR}).....	$V_{IN} + 0.3V$
RC	$V_{IN} + 0.3V$
Power Dissipation.....	Internally Limited ⁽³⁾
Junction Temperature	$-40^{\circ}C \leq T_J \leq +125^{\circ}C$
Storage Temperature (T_S).....	$-65^{\circ}C \leq T_J \leq +150^{\circ}C$
ESD Rating ⁽⁴⁾	2KV

Operating Ratings⁽²⁾

Supply voltage (V_{IN})	1.65V to 5.5V
Enable Input Voltage (V_{EN}).....	0V to V_{IN}
Ramp Control (V_{RC}).....	0V to 5.5V
Junction Temperature Range	$-40^{\circ}C \leq T_J \leq +125^{\circ}C$
Package Thermal Resistance	
3x3 MLF-10 (θ_{JA})	60°C/W

Electrical Characteristics⁽⁵⁾

$T_A = 25^{\circ}C$ with $V_{IN} = V_{OUT} + 1V$; $V_{EN} = V_{IN}$; $I_{OUT} = 10mA$; **bold** values indicate $-40^{\circ}C \leq T_J \leq +125^{\circ}C$, unless noted.

Parameter	Conditions	Min	Typ	Max	Units
Output Voltage Accuracy	$10mA < I_{OUT} < I_{L(max)}$, $V_{OUT} + 1 \leq V_{IN} \leq 5.5V$	-2		+2	%
Output Voltage Line Regulation	$V_{IN} = V_{OUT} + 1V$ to 5.0V		0.06	0.5	%
Output Voltage Load Regulation	$I_L = 0mA$ to 2A		0.3	1	%
$V_{IN} - V_O$; Dropout Voltage	$I_L = 500mA$		140	300	mV
	$I_L = 1.0A$		220	500	mV
	$I_L = 2.0A$		330	700	mV
Ground Pin Current	$I_L = 10mA$		1.5		mA
	$I_L = 500mA$		7	15	mA
	$I_L = 1.0A$		15	30	mA
	$I_L = 2.0A$		42	80	mA
Shutdown Current	$V_{EN} = \leq 0.55V$; $V_{OUT} = 0V$		0.01	10	μA
Current Limit	$V_{OUT} = 0V$; $V_{IN} = 3.0V$	2.0	3.4	6.0	A
Start-up Time	$V_{EN} = V_{IN}$; $C_{RC} = \text{Open}$		25	150	μs
Enable Input					
Enable Input Threshold	Regulator enable	1			V
	Regulator shutdown			0.2	V
Enable Hysteresis		50	100	250	mV
Enable Input Current	$V_{IL} \leq 0.2V$ (Regulator shutdown)		0.8		μA
	$V_{IH} \leq 1V$ (Regulator enable)		2		μA
POR Output					
$I_{POR(LEAK)}$	$V_{POR} = 5.5V$; POR = High			1	μA
				2	μA
$V_{POR(LO)}$	Output Logic-Low Voltage (undervoltage condition), $I_{POR} = 1mA$		60		mV
V_{POR} : V_{OUT} Ramping Up V_{OUT} Ramping Down	Threshold, % of V_{OUT} below nominal	7.5	10	12.5	%
		10	12.5	15	%
Delay Current	$V_{DELAY} = 0V$	0.7	1	1.3	μA
Delay Voltage (Note 6)	$V_{POR} = \text{High}$	1.185	1.235	1.285	V

Parameter	Conditions	Min	Typ	Max	Units
Ramp Control					
I_{RAMP}	Ramp Control Current	0.7	1	1.3	μA
$I_{DISCHARGE(OUTPUT)}$ (Note 7)	$V_{OUT} = 0.5V_{REF}$, $V_{RAMP} = 0V$	25	45		mA
Tracking Accuracy: (Note 8)	Fixed $200mV < V_{RC} < V_{TARGET}$; Measure ($V_{OUT} - V_{RC}$) Measure ($V_{OUT} - V_{RC} \times (V_{TARGET} / 500mV)$)	5	10	100	mV

Notes:

1. Exceeding the absolute maximum rating may damage the device.
2. The device is not guaranteed to function outside its operating rating.
3. The maximum allowable power dissipation of any T_A (ambient temperature) is $P_{D(max)} = T_{J(max)} - T_A / \theta_{JA}$. Exceeding the maximum allowable power dissipation will result in excessive die temperature, and the regulator will go into thermal shutdown.
4. Devices are ESD sensitive. Handling precautions recommended. Human body model, 1.5k in series with 100pF.
5. Specification for packaged product only.
6. Timer High Voltage along with Delay pin current (1 μA nom) determines the delay per uF of capacitance. Typical delay is 1.1sec/ μf
7. Discharge current is the current drawn from the output to ground to actively discharge the output capacitor during the shutdown process.
8. V_{TARGET} is the output voltage of an adjustable with customer resistor divider installed between V_{OUT} and Adj/Sns pin, or the rated output voltage of a fixed device.

Typical Characteristics

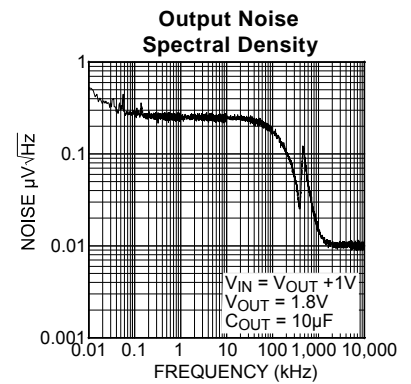
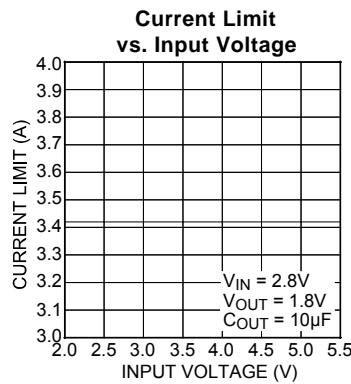
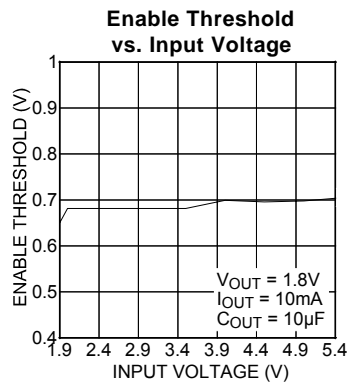
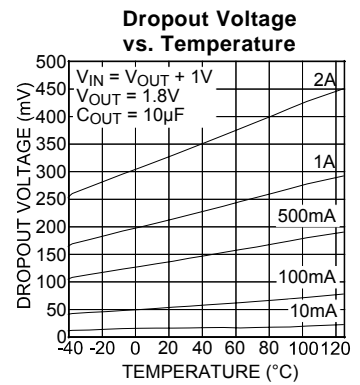
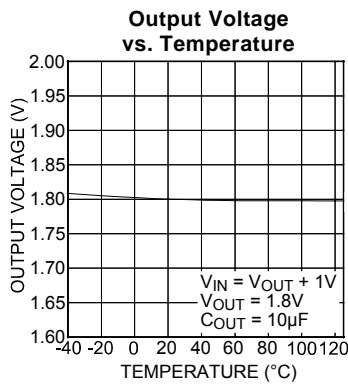
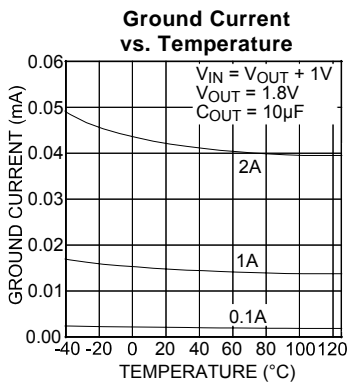
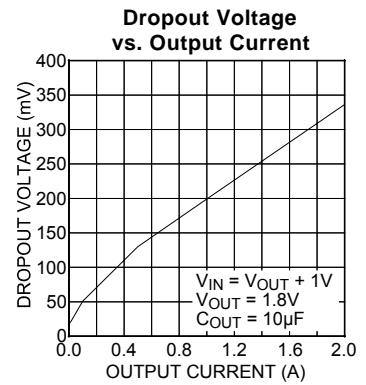
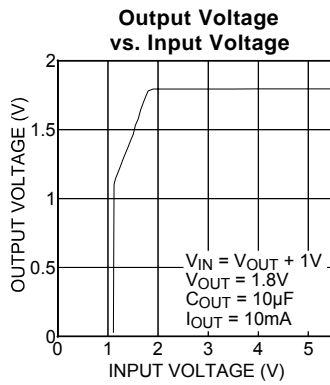
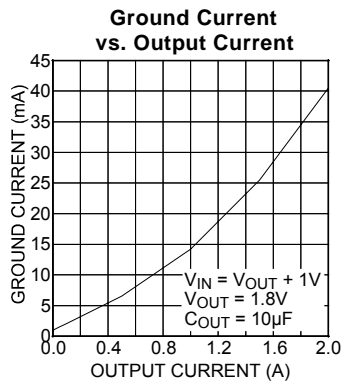

Functional Characteristics

Enable Turn-On

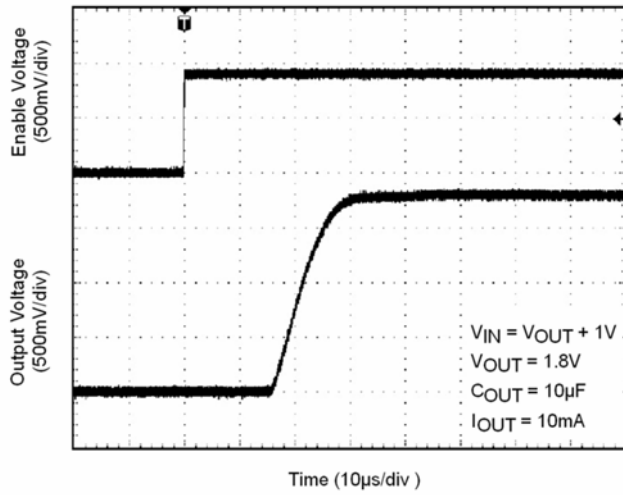

Line Transient

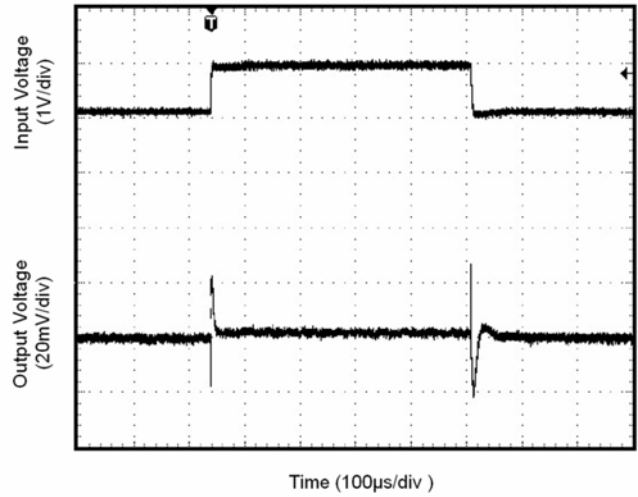

Load Transient

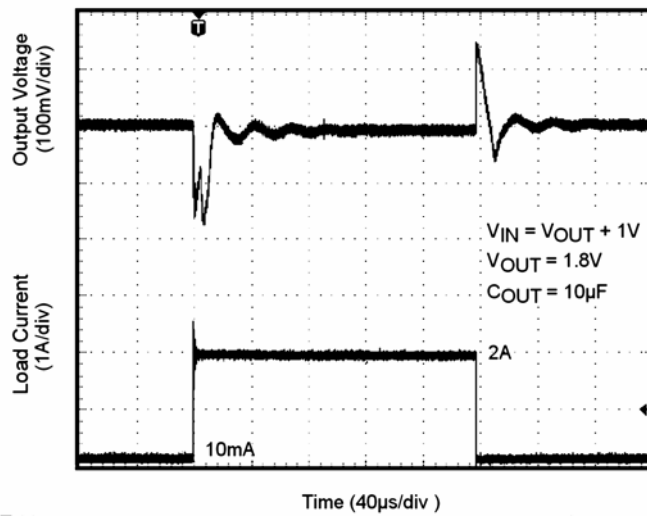

Applications Information

Enable Input

The MIC68200 features a TTL/CMOS compatible positive logic enable input for on/off control of the device. High (>1V) enables the regulator while low (<.2V) disables the regulator. In shutdown, the regulator consumes very little current (only a few microamperes of leakage). For simple applications, the enable can be connected to V_{IN} . While the MIC68200 only requires a few μA 's of enable current to turn on, actual enable pin current will depend upon the overdrive (voltage exceeding 1V) in each particular application.

Enable Connections for Logic Driven input

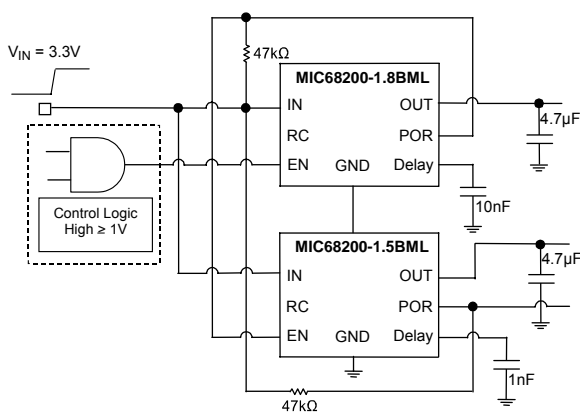

Enable Connection for V_{IN} -Driven and/or Slow Risetime Inputs

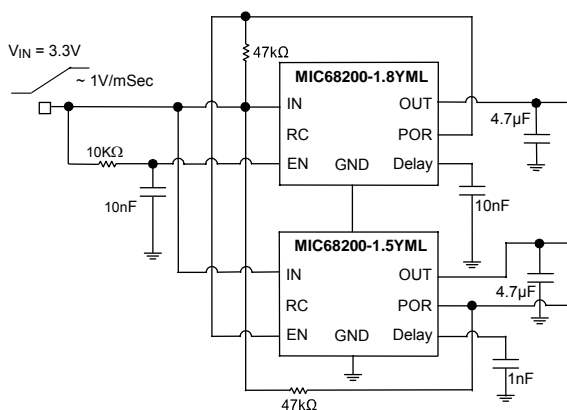

Input Capacitor

An input capacitor of 0.1 μF or greater is recommended when the device is more than 4 inches away from the bulk supply capacitance, or when the supply is a battery. Small, surface mount chip capacitors can be used for the bypassing. The capacitor should be placed within 1 inch of the device for optimal performance. Larger values will help to improve ripple rejection by bypassing the regulator input, further improving the integrity of the output voltage.

Output Capacitor

The MIC68200 requires an output capacitor for stable operation. As a μCap LDO, the MIC68200 can operate with ceramic output capacitors of 4.7 μF or greater with ESR's ranging from a 3m Ω to over 300m Ω . Values of greater than 4.7 μF improve transient response and noise reduction at high frequency. X7R/X5R dielectric-type ceramic capacitors are recommended because of their superior temperature performance. X7R-type capacitors change capacitance by 15% over their operating temperature range and are the most stable type of ceramic capacitors. Larger output capacitances can be achieved by placing tantalum or aluminum electrolytics in parallel with the ceramic capacitor. For example, a 100 μF electrolytic in parallel with a 4.7 μF ceramic can provide the transient and high frequency noise performance of a 100 μF ceramic at a significantly lower cost. Specific undershoot/overshoot performance will depend upon both of the values and ESR/ESL of the capacitors.

Adjustable Regulator Design

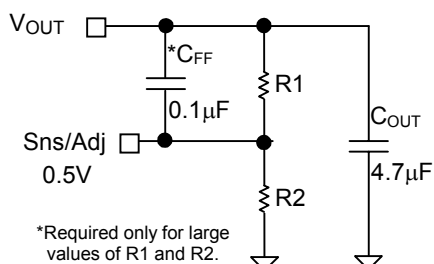

Adjustable Regulator with Resistors

The adjustable MIC68200 output voltage can be programmed from 0.5V to 5.5V using a resistor divider from output to the ADJ/SNS pin. Resistors can be quite large, up to 1MΩ because of the very high input impedance and low bias current of the sense amplifier. Typical sense input currents are less than 30nA which causes less than 0.3% error with R1 and R2 less than or equal to 1MΩ. For large value resistors (>50K) R1 should be bypassed by a small capacitor ($C_{FF} = 0.1\mu\text{F}$ bypass capacitor) to avoid instability due to phase lag at the ADJ/SNS input.

The output resistor divider values are calculated by:

$$V_{\text{OUT}} = 0.5V \left(\frac{R1}{R2} + 1 \right)$$

Power on Reset (POR) and Delay

The power-on reset output (POR) is an open-drain N-Channel device requiring a pull-up resistor to either the input voltage or output voltage for proper voltage levels. POR is driven by the internal timer so that the release of POR at turn-on can be delayed for as much as 1 second. POR is always pulled low when enable (EN) is pulled low or the output goes out of regulation by more than 10% due to loading conditions.

The internal timer is controlled by the DELAY pin which has a bidirectional current source and two limiting comparators. A capacitor connected from DELAY to GND sets the delay time for two functions. On start up, DELAY sets the time from power good to the release of the POR. At shut down, the delay sets the time from disable (ENABLE pin driven low) to actual ramp down of the output voltage. The current source is $\pm 1\mu\text{A}$, which charges the capacitor from $\sim 150\text{mV}$ (nominal disabled DELAY voltage) to $\sim 1.25\text{V}$. At turn on, the DELAY cap begins to charge when the output voltage reaches 90% of the target value. When the capacitor reaches 1.25V, the output of the POR is released to go high. At turn off, the DELAY cap begins to discharge when the ENABLE is driven low. When the cap reaches $\sim 150\text{mV}$ the output

is ramped down. Both delays are nominally the same, and are calculated by the same formula:

$$T_{\text{SHUTDOWN}} = T_{\text{POR}} = (1.13) \left(\frac{C_{\text{RAMP}}}{1\mu\text{A}} \right)$$

Scale Factor is:

- 1.13 seconds/microfarad,
- 1.13 milliseconds/nanofarad, or
- 1.13 nanoseconds/picofarad.

This behavior means that a μP or other complex logic system is guaranteed that power has been good for a known time before the POR is released, and they are further guaranteed that once POR is pulled low, they have a known time to 'tidy up' memory or other registers for a well controlled shutdown. In Master/Slave configurations, the timers can be used to assure that the Master is always accurately regulating when the Slave is on.

Ramp Control

The ramp control (RC) has a bidirectional current source and a sense amplifier, which together are used to control the voltage at the output. When RC is below the target voltage (nominal output voltage for fixed voltage parts, 0.5V for adjustable parts) the RC pin controls the output voltage. When RC is at or above the target voltage, the output is controlled by the internal regulator.

Tracking Applications: Driving RC from a Voltage Source

Fixed Parts: If RC is driven from another (Master) regulator the two outputs will track each other until the Master exceeds the target voltage of the Slave regulator. Typically, the output of the MIC68200 will track above the RC input by 30mV to 70mV. This offset is designed to allow Master/Slave tracking of same-voltage regulators. Without the offset, same-voltage Master/Slave configurations could suffer poor regulation.

Adjustable Parts: The RC pin on adjustable versions operates from 0V to 0.5V. To implement tracking on an adjustable version, an external resistor divider must be used. This divider is the nearly same ratio as the voltage setting divider used to drive the Sense/Adj pin. It is recommended that the ratio be adjusted to track $\sim 50\text{mV}$ (2% to 3%) above the target voltage if the Master and Slave are operating at the same target voltage.

Ramp Up: Cap Controlled Slew Rate

If a capacitor is connected to RC, the bidirectional current source will charge the cap during startup and discharge the cap during shutdown. The size of the capacitor and the RC current (1µA nom) control the slew rate of the output voltage during startup. For example, to slew a 1.8V regulator from zero to full output in 10mSec requires a 5.6nF capacitor.

For Fixed Versions:

$$T_{SLEW} = V_{OUT} \left(\frac{C_{RAMP}}{1\mu A} \right)$$

Similarly, to slew an adjustable (any output voltage) from 0 to full output in 10mSec requires a 20nF cap.

For Adjustable Versions:

$$T_{SLEW} = 0.5V \left(\frac{C_{RAMP}}{1\mu A} \right)$$

Ramp Down: Turn Off Slew Rate

When EN is pulled low, the RC current is reversed and the RC capacitor begins to discharge. When the RC capacitor has fully discharged the output begins to ramp down. The delay is the same as the POR delay during turn on, and the same formula applies.

$$T_{SHUTDOWN} = (1.13) \left(\frac{C_{RAMP}}{1\mu A} \right)$$

Sequencing Configurations

Sequencing refers to timing based Master/Slave control between regulators. It allows a Master device to control the start and stop timing of a single or multiple Slave devices. In typical sequencing, the Master POR drives the Slave EN. The sequence begins with the Master EN driven high. The Master output then ramps up and triggers the Master DELAY when the Master output reaches 90%. The Master DELAY then determines when the POR is released to enable the Slave device. When the Master EN is driven low, the Master POR is immediately pulled low causing the Slave to ramp down. However, the Master output will not ramp down until the Master DELAY has fully discharged. In this way, the Master power can remain good after the Slave has been ramped down.

In sequencing configurations the Master DELAY controls the turn-on time of the Slave and the Slave DELAY controls the turn-off time of the Slave.

Sequencing Connections

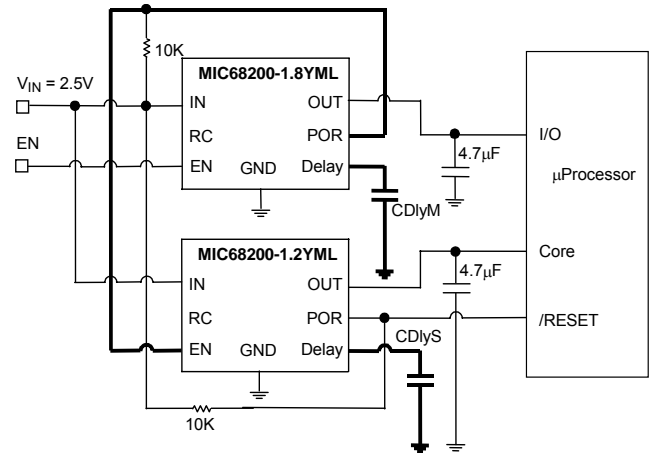

Delayed Sequencing

CDlyS > CDlyM [CDlyS=2nF; CDlyM=1nF]

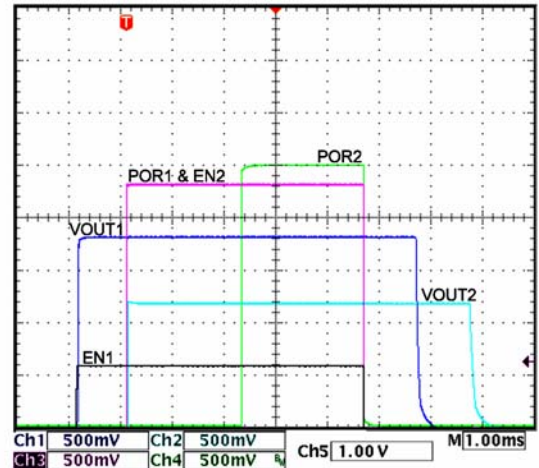

Windowed Sequencing

CDlyS < CDlyM [CDlyS=1nF; CDlyM=2nF]

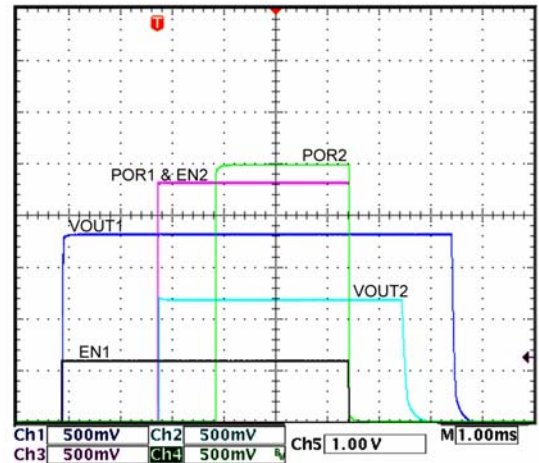

Tracking Configurations

Normal Tracking

In normal tracking the Slave RC pin is driven from the Master output. The internal control buffering assures that the output of the Slave is always slightly above the Master to guarantee that the Slave properly regulates (based on its own internal reference) if Master and Slave are both fixed voltage devices of the same output voltage. The schematic and plot below show a 1.2 volt device tracking a 1.8 volt device through the entire turn-on / turn-off sequence. Note that since the RC pin will overdrive the target voltage (to assure proper regulation) the ramp down delay is longer than the POR delay during turn-on.

Fixed Voltage Devices

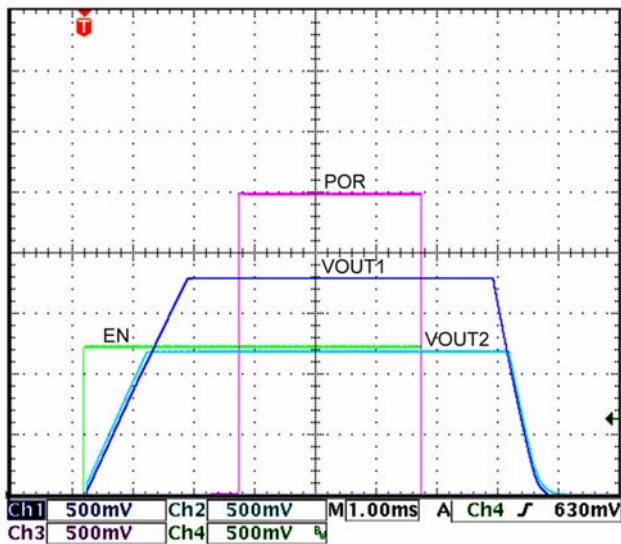
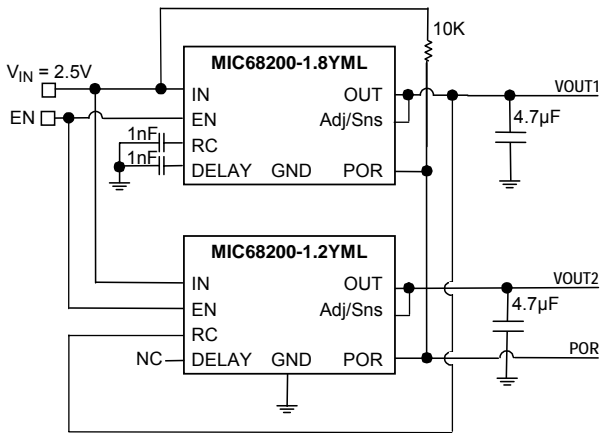

Fixed voltage versions of MIC68200 have two internal voltage dividers: one for setting the output voltage and the other for driving the tracking circuitry. Adjustable parts have up to two external dividers: one from output to Adj/Sns (to set the output voltage) and one from the output to the Slave RC pin (in tracking configurations). Also, the RC pin in fixed parts operates at the same voltage as the output, whereas the RC pin in adjustable parts operates at the 0.5V reference. To setup a normal tracking configuration, the divider driving the Slave RC pin is the same ratio (or nearly the same – if both Master and Slave are set to the same output voltage, the Slave RC divider should be adjusted 2% to 4% higher) as the divider driving the Slave Adj/Sns pin. This is shown below.

Adjustable Voltage devices

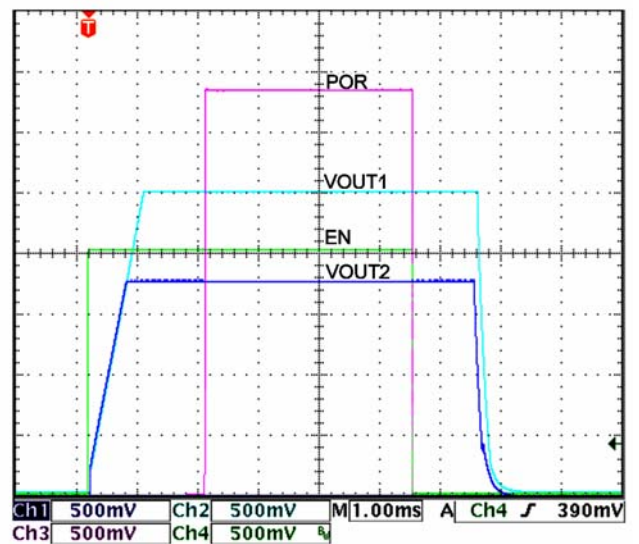
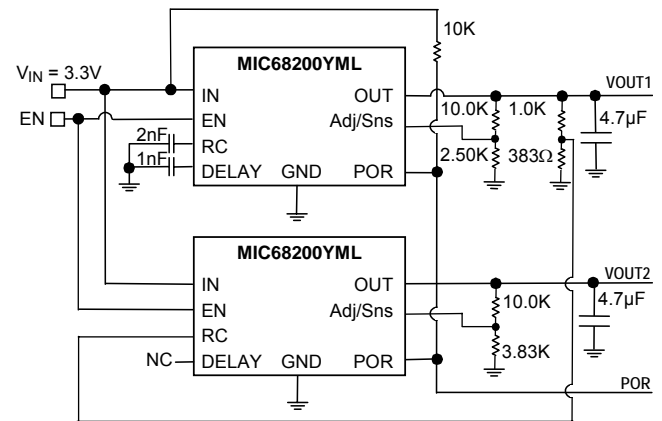

Ratiometric Tracking

Ratiometric tracking allows independent ramping speeds for both regulators so that the regulation voltage is reached at the same time. This is accomplished by adding a resistor divider between the Master output pin and the Slave RC pin. The divider should be scaled such that the Slave RC pin reaches or exceeds the target output voltage of the Slave as the Master reaches its target voltage.

Ratiometric tracking may be used with adjustable parts by simply connecting the RC pins of the Master and Slave. Use a single RC capacitor of twice the normal value (since twice the current is injected into the single RC cap). Alternatively, adjustable parts may use ratiometric tracking in a manner similar to standard tracking, with the tracking divider changed to the same resistor ratio driving the Master Adj/Sns pin.

Fixed Voltage Devices

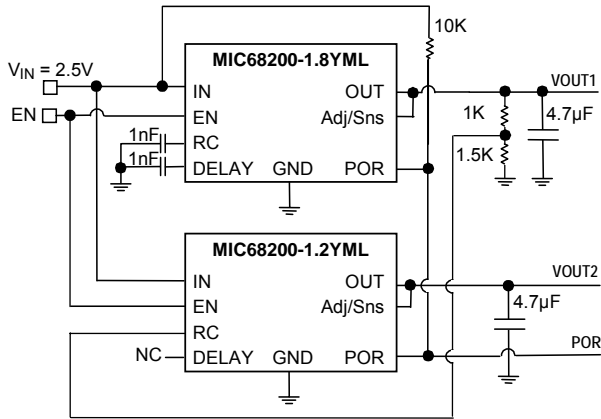

Adjustable Voltage Devices

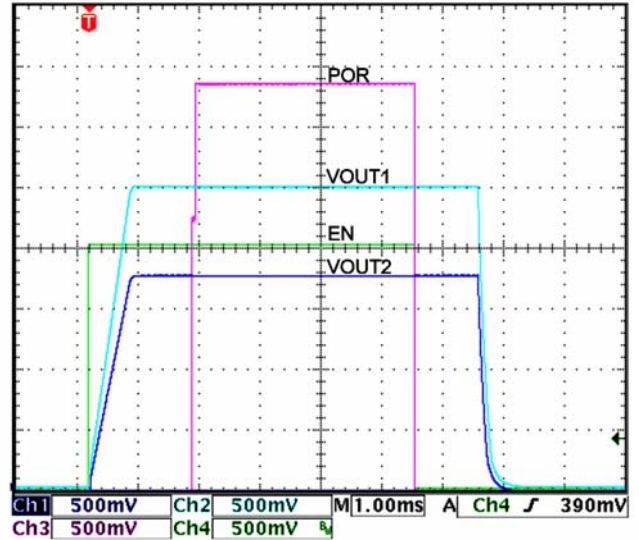
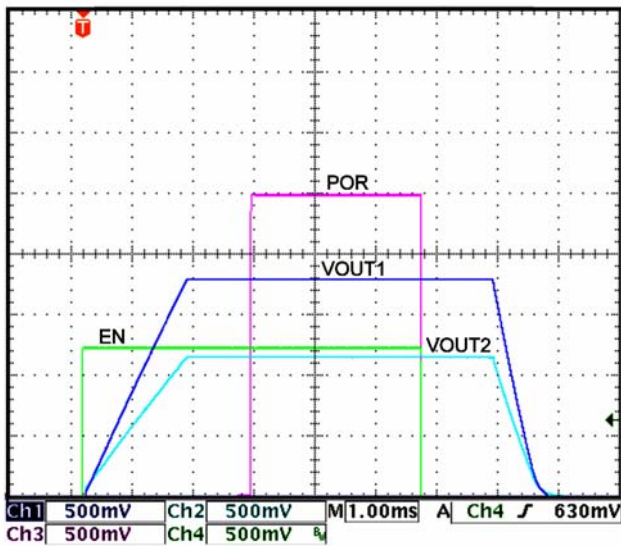
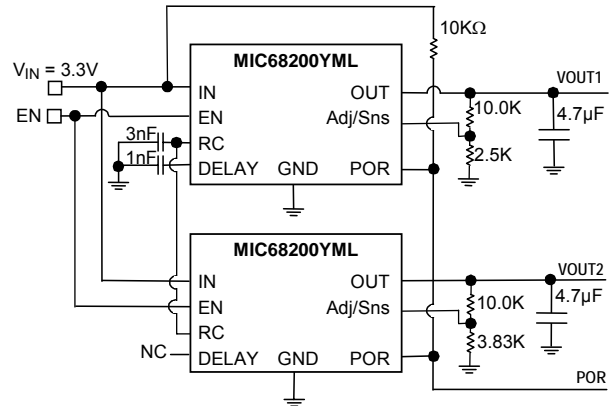

Package Information

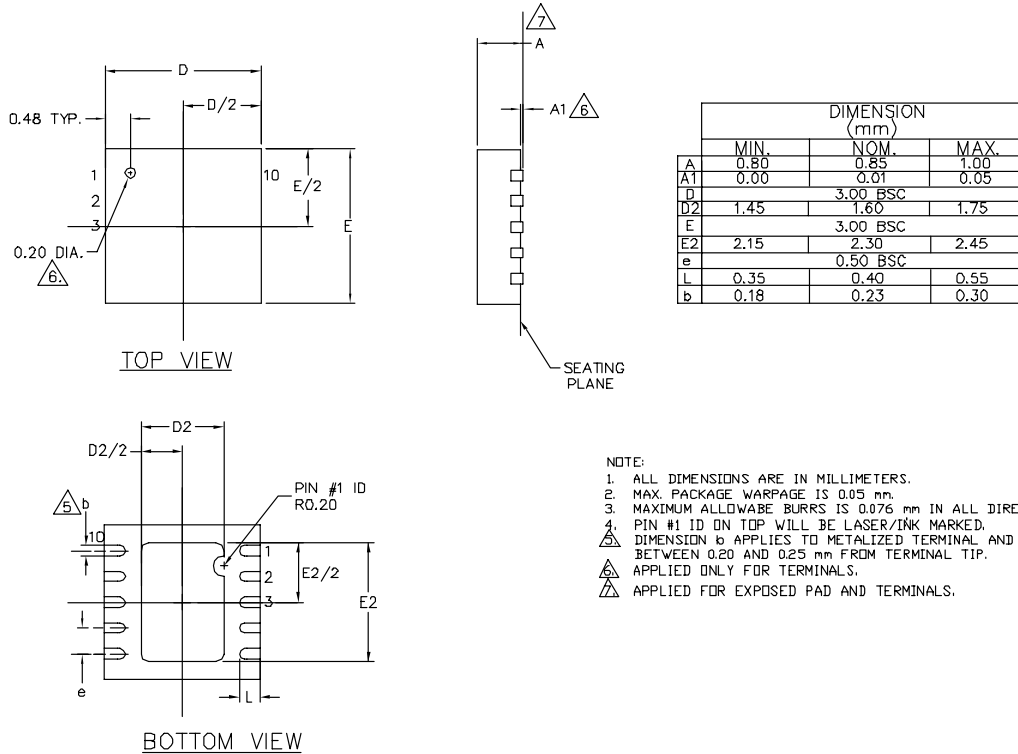

10-Pin 3mm x 3mm MLF (ML)

MICREL, INC. 2180 FORTUNE DRIVE SAN JOSE, CA 95131 USA
 TEL +1 (408) 944-0800 FAX +1 (408) 474-1000 WEB <http://www.micrel.com>

The information furnished by Micrel in this data sheet is believed to be accurate and reliable. However, no responsibility is assumed by Micrel for its use. Micrel reserves the right to change circuitry and specifications at any time without notification to the customer.

Micrel Products are not designed or authorized for use as components in life support appliances, devices or systems where malfunction of a product can reasonably be expected to result in personal injury. Life support devices or systems are devices or systems that (a) are intended for surgical implant into the body or (b) support or sustain life, and whose failure to perform can be reasonably expected to result in a significant injury to the user. A Purchaser's use or sale of Micrel Products for use in life support appliances, devices or systems is a Purchaser's own risk and Purchaser agrees to fully indemnify Micrel for any damages resulting from such use or sale.

© 2005 Micrel, Inc.