

## Preliminary data

Bipolar IC

Type	Ordering code	Package
TDA 5651	Q67000-A2463	DIP 22

The integrated circuit TDA 5651 includes the essential features for sound processing in video tape recorders

such as

- Amplification and adjustment of levels
- Setting of the required input and output impedances
- Switch-over between 4 signal sources
- Switch-over from recording to playback mode
- Muting pulse
- Adjustment of the switching signals (point 3-5) to bus-compatible control levels
- Automatic level control
- Setting of the recording and playback frequency response through external negative feedback

**Maximum ratings**

	min	max	
Input microphone amplifier		$V_{REF}$	V
Input playback amplifier		$V_{REF}$	V
Output playback amplifier	-5		mA
Output playback amplifier		6	V
Input AF signal		$+V_S$	V
Time constant muting pulse	0	$V_{REF} + 5$	V
Logic input	0	$+V_S$	V
Supply voltage	0	20	V
Output AF signal	0		V
Output AF signal		5	mA
Input AF amplifier	0	$V_{REF} + 5$	V
Input recording amplifier	0	$+V_S$	V
Output recording amplifier	-5	+5	mA
Logic input		$+V_S$	V
Logic input		$+V_S$	V
Input/Output AV signal	0	$+V_S$	V
Time constant level control	0	$+V_S$	V
Output level control	0	7	V
Reference voltage blocking	-5		mA
Reference voltage blocking		7	V
Junction temperature		150	°C
Storage temperature range	-40	125	°C
Thermal resistance (system-ambient air)		65	K/W

**Operating range**

Supply voltage	$V_S$	9.8 to 14	V
Frequency	$f_{max}$	15	kHz
0 dB		10	kHz
Ambient temperature	$T_A$	0 to 60	°C

**Characteristics** $V_S = 12\text{ V}$ ;  $T_A = 25^\circ\text{C}$ 

Current consumption

 $V_S = 12\text{ V}$ , AF, without signal

	min	typ	max	
$I_S$		15	25	mA

**Recording mode**

Microphone input

Input impedance

Input signal 1 kHz

Signal-to-noise ratio, microphone  
according to plot A,  $V_{i\text{rms}} = 1\text{ mV}$ 

$R_{iM}$	-25%	10	+25%	$k\Omega$
$V_{iM\text{rms}}$	1.0		50	mV
	40 <sup>1)</sup>			dB

AV input

Input impedance

Input signal 1 kHz

AV signal-to-noise ratio

according to plot A,  $V_{i\text{rms}} = 100\text{ mV}$ 

$R_{iAV}$	10			$k\Omega$
$V_{iAV\text{rms}}$	0.15	1.0	2	V
	60			dB

AF input

Input impedance

Input signal 1 kHz

AF signal-to-noise ratio

according to plot A,  $V_{i\text{rms}} = 100\text{ mV}$ 

$R_{iAF}$	50			$k\Omega$
$V_{iAF\text{rms}}$	0.15	0.3	2	V
	60			dB

AF output (monitor)

Output impedance

Output signal

Total harmonic distortion

with 1 kHz

 $V_i = 1\text{ V}$  at AF output

$R_{q13}$			0.1	$k\Omega$
$V_{q13\text{rms}}$		1		V
<i>THD</i>			1.5	%
<i>THD</i> <sub>3</sub>			0.5	%

**Playback mode**

Playback head input

Input current

Input signal at 330 Hz

Input voltage

$I_3$			100	nA
$V_{ip}$		60 <sup>2)</sup>		$\mu\text{V}$
$V_3$	2.4	2.7	3.0	V

AV output

Output impedance

Output signal

1  $V_{\text{rms}}$  at pin 13

Playback gain at 330 Hz

Signal-to-noise ratio referred

to playback head

 $V_{ip} = 180\ \mu\text{V}$ according to plot A,  $R_{ip} = 10\ \Omega$ 

Total harmonic distortion

with 1 kHz;  $V_{ip} = 200\ \mu\text{V}$ 

$R_{q19}$			1	$k\Omega$
$V_{q19\text{rms}}$				V
		84 <sup>2)</sup>		dB
	56 <sup>2)</sup>			dB
<i>THD</i>			1.5	%
<i>THD</i> <sub>3</sub>			0.5	%

1) Objective is 46 dB

2) Including preamplifier and circuitry; refer to figure



## Truth table

		Switching inputs		
		A	B	C
Recording, microphone	M	1	0	0
Recording A/V	A/V	1	0	1
Playback	P	1	1	0
Recording, AF	AF	1	1	1
Mute mode	S	0	X	X

## Pin description

Pin	Function
1	GND
2	Input recording microphone
3	Input playback and frequency response playback
4	Output playback amplifier
5	Input recording AF (IF)
6	Time constant for switch-over and soft sound gain control
7	Logic input (muting pulse)
8	Supply voltage
9	Not connected
10	Not connected
11	Not connected
12	Not connected
13	Output AF (monitor)
14	Line stop filter
15	Frequency response, recording
16	Output recording (head)
17	Logic input (switch-over)
18	Logic input (switch-over)
19	Input recording AV
20	Time constant level control
21	Line stop filter (output level control)
22	Capacitive support C $V_{REF}$

Block diagram

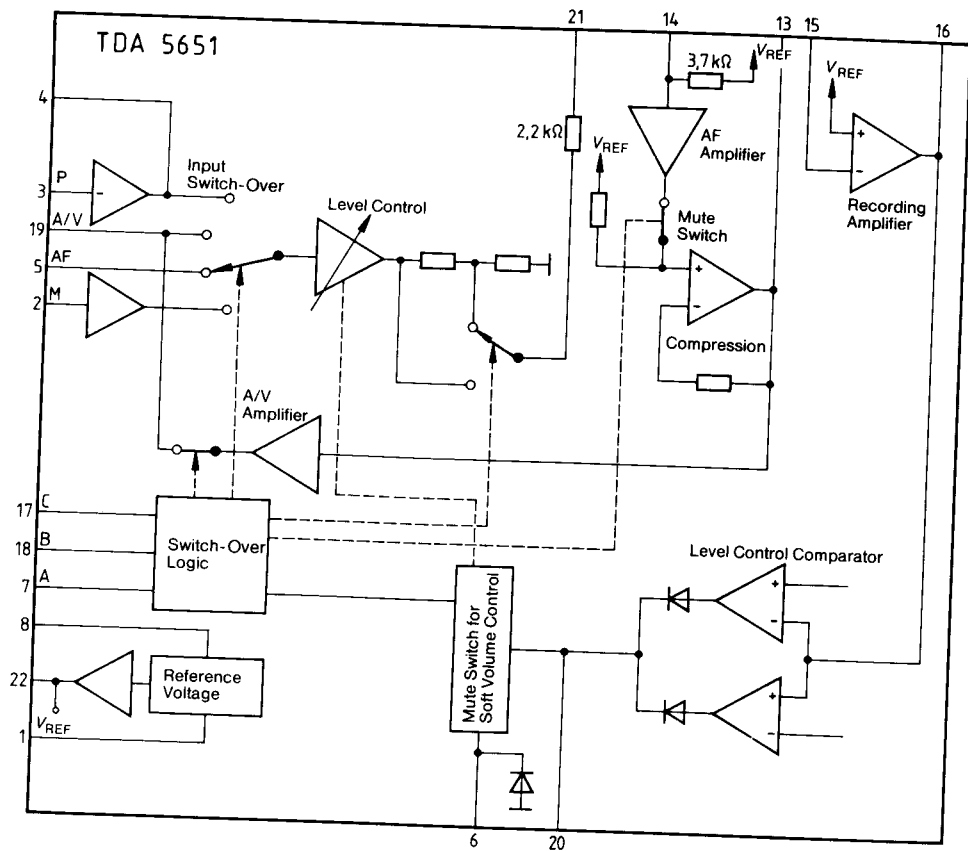

Test and measurement circuit

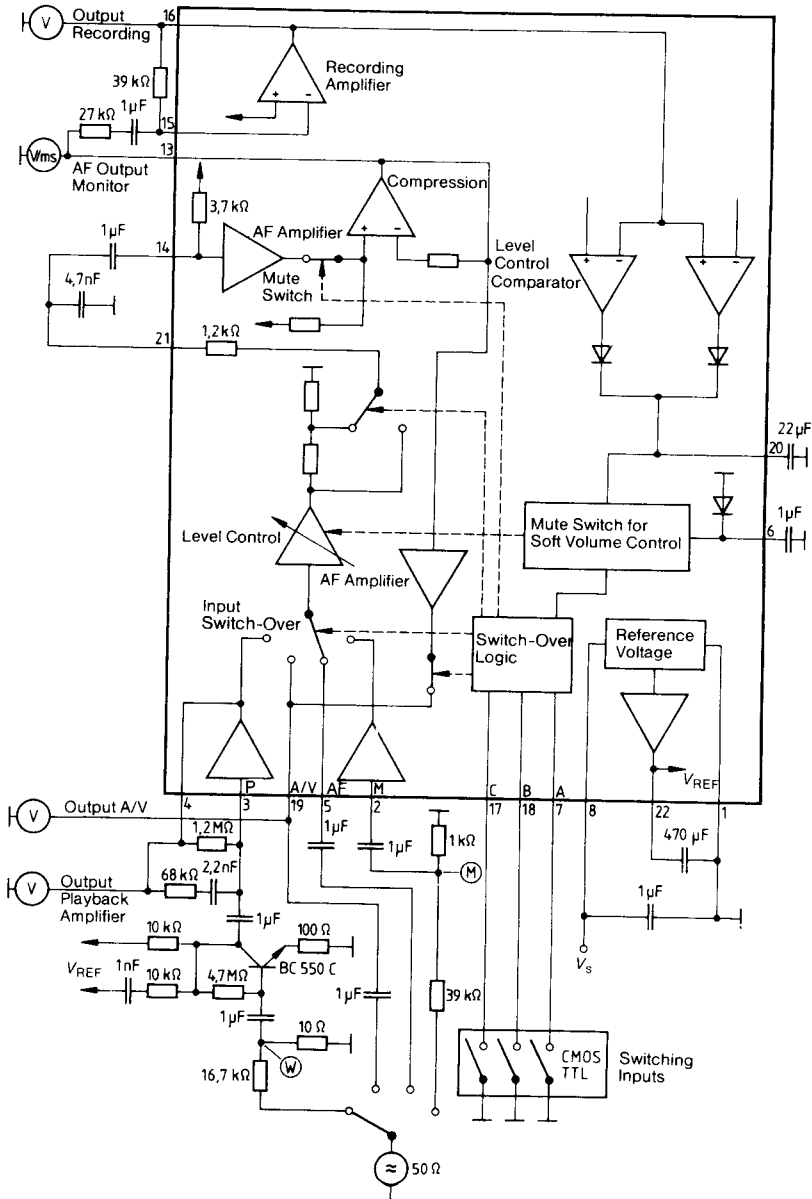

Application circuit

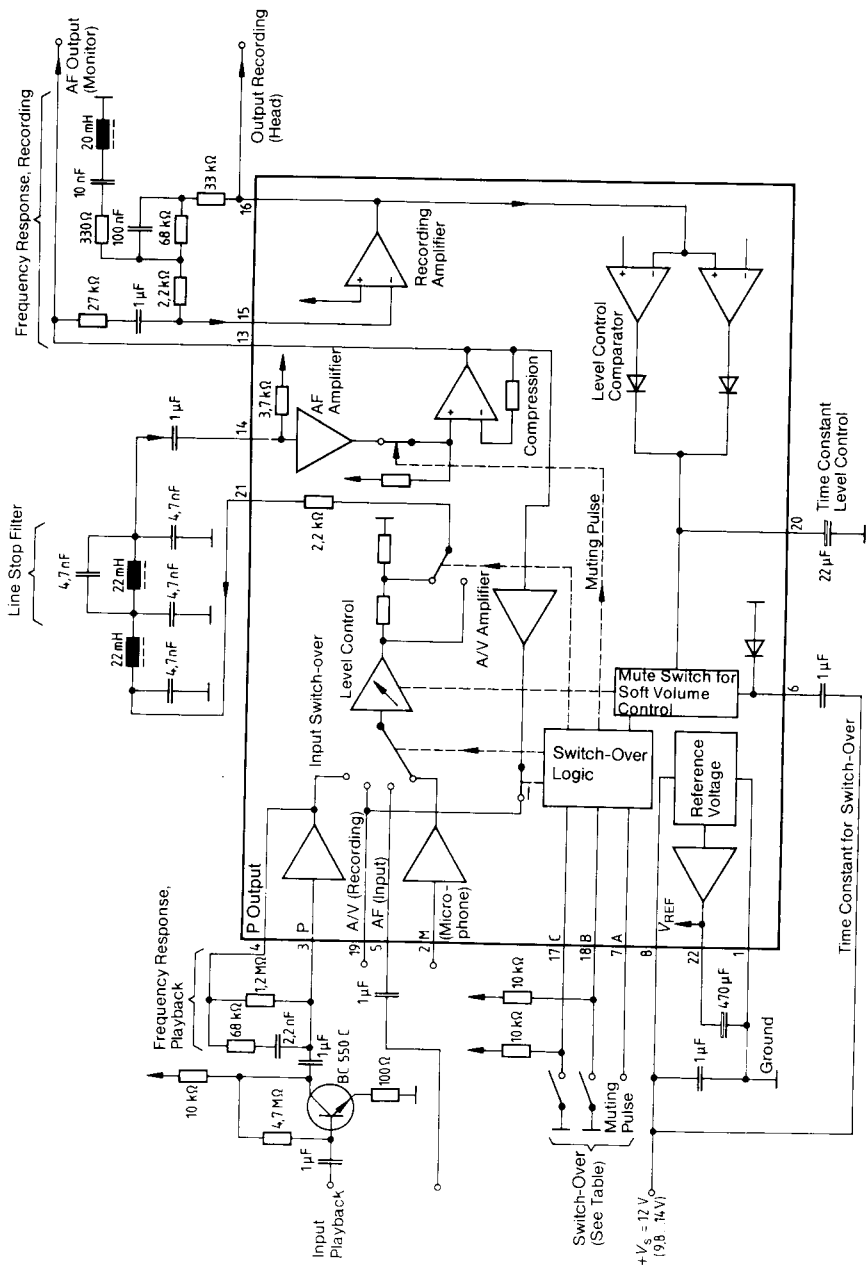

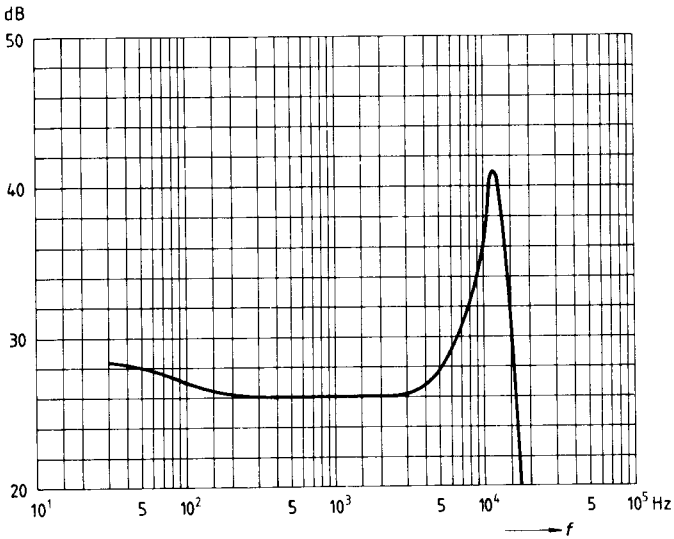

**Frequency responses****Recording mode (AF input – recording output)  
realizable frequency response****Playback mode (preamplifier input – monitor output)  
realizable frequency response**