



**Winbond**  
**Bus Termination Regulator**  
**W83310S-R/N**

Date: May 21, 2003    Revision: 0.61



## W83310S-R/N Data Sheet Revision History

	PAGES	DATES	VERSION	WEB VERSION	MAIN CONTENTS
1	N.A.	12/2002	0.51	N.A.	The versions before 0.5 are only for internal reference.
2	3	02/2003	0.60	N.A.	Recommend circuit update
3	5	03/2003	0.61	N.A.	AC specification update

Please note that all data and specifications are subject to change without notice. All the trademarks of products and companies mentioned in this datasheet belong to their respective owners.

### LIFE SUPPORT APPLICATIONS

These products are not designed for use in life support appliances, devices, or systems where malfunction of these products can reasonably be expected to result in personal injury. Winbond customers using or selling these products for use in such applications do so at their own risk and agree to fully indemnify Winbond for any damages resulting from such improper use or sales.



## W83310S-R/N Data Sheet Revision History

	PAGES	DATES	VERSION	WEB VERSION	MAIN CONTENTS
1	N.A.	12/2002	0.51	N.A.	The versions before 0.5 are only for internal reference.
2	3	02/2003	0.60	N.A.	Recommend circuit update
3	5	03/2003	0.61	N.A.	AC specification update

Please note that all data and specifications are subject to change without notice. All the trademarks of products and companies mentioned in this datasheet belong to their respective owners.

### LIFE SUPPORT APPLICATIONS

These products are not designed for use in life support appliances, devices, or systems where malfunction of these products can reasonably be expected to result in personal injury. Winbond customers using or selling these products for use in such applications do so at their own risk and agree to fully indemnify Winbond for any damages resulting from such improper use or sales.



## **Table of Content-**

1.	GENERAL DESCRIPTION .....	1
2.	FEATURES.....	1
3.	APPLICATIONS.....	1
4.	PIN CONFIGURATION AND DESCRIPTION.....	2
5.	APPLICATION CIRCUIT.....	3
6.	INTERNAL BLOCK DIAGRAM .....	4
7.	ELECTRICAL CHARACTERISTICS.....	6
8.	TYPICAL OPERATING WAVEFORM.....	7
9.	PACKAGE DIMENSION .....	10
10.	ORDERING INFORMATION .....	11
11.	HOW TO READ THE TOP MARKING.....	11

## 1. GENERAL DESCRIPTION

The W83310S-R/N is a linear regulator which provides achieves 1.5Amp bi-directional sinking and driving capability for DDR SDRAM bus terminator application. The chip simply implement a stable power supply which can track half of input power dynamically for bus terminator with a single chip; that is the chip integrates two power MOSFETs. There is no any external power device needed. The W83310S-R/N is promoted with small footprint 8-SOP 150mil package. With W83301S-R/N design, a high integration, high performance, and cost-effective solution is promoted.

## 2. FEATURES

- ❖ Regulates a bi-directional power with driving and sinking capability
- ❖ Provides achieve 1.5Amp driving and sinking current
- ❖ Power MOSFET integrated
- ❖ Low external component count
- ❖ Low output voltage offset
- ❖ Operates with +5V,+3.3V and +2.5V power
- ❖ Small package
- ❖ Low cost and easy to use

## 3. APPLICATIONS

- ❖ DDR Bus Termination Regulator
- ❖ Active Termination Bus
- ❖ SSTL-2
- ❖ SSTL-3

4. PIN CONFIGURATION AND DESCRIPTION

- W83310S-R



SYMBOL	PIN	FUNCTION
VIN	1	Power input pin.
GND	2	Ground.
VREF	3	Reference voltage and Chip enable.
VOUT	4	Output voltage.
VCNTL	5	Gate drive voltage.
VCNTL	6	Gate drive voltage.
VCNTL	7	Gate drive voltage.
VCNTL	8	Gate drive voltage.

- W83310S-N



SYMBOL	PIN	FUNCTION
N/C	1	No internal connection.
GND	2	Ground.
VSENSE	3	Feedback pin for regulating VTT.
VREF	4	Internal reference voltage of VDDQ/2.
VDDQ	5	Input for internal reference equal to VDDQ/2.
AVIN	6	Analog input pin.
PVIN	7	Power input pin.
VTT	8	Output voltage for connection to termination resistors.

## 5. APPLICATION CIRCUIT

### - W83310S-R

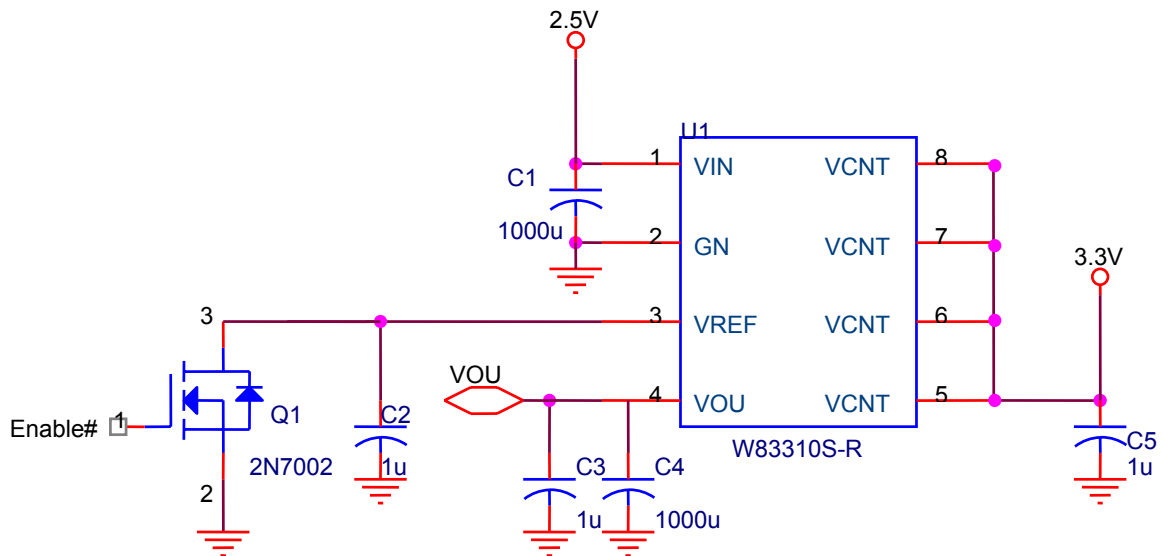

- W83310S-N

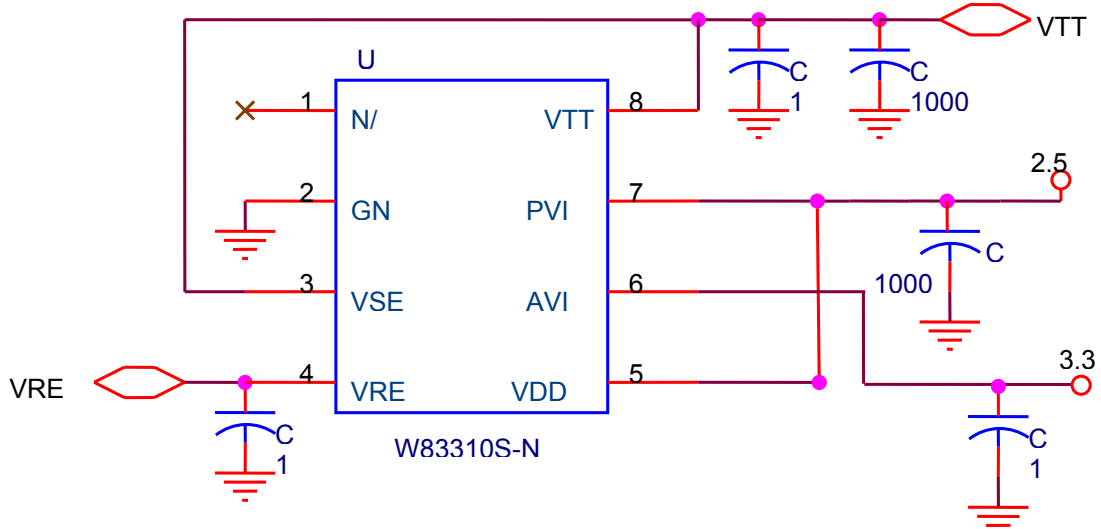

6. INTERNAL BLOCK DIAGRAM

- W83310S-R

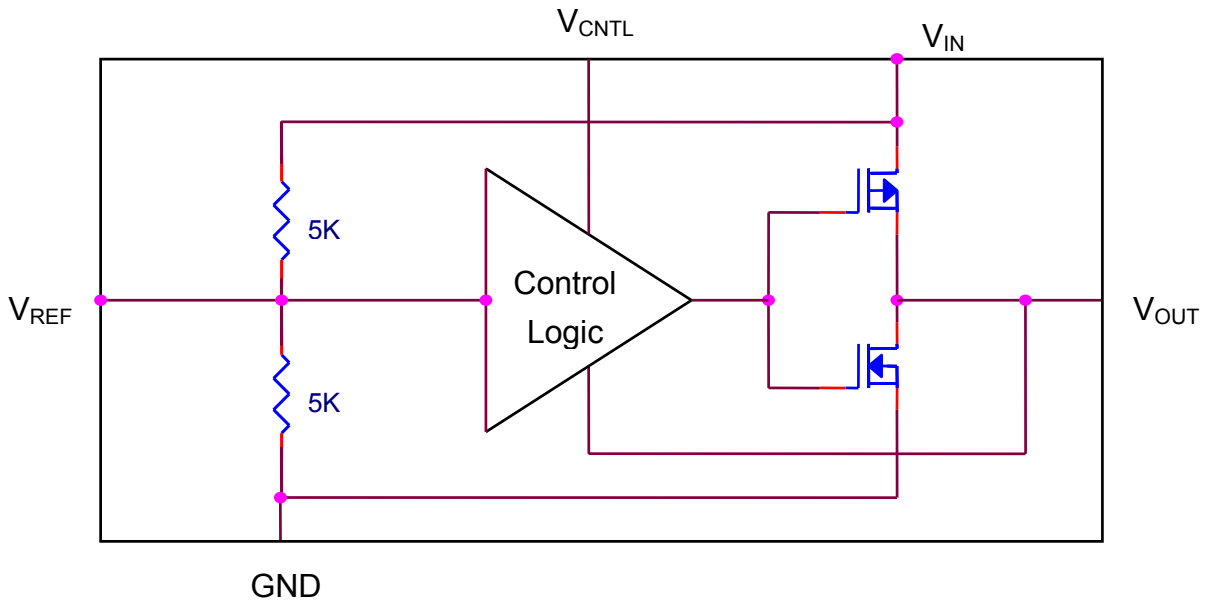



- W83310S-N

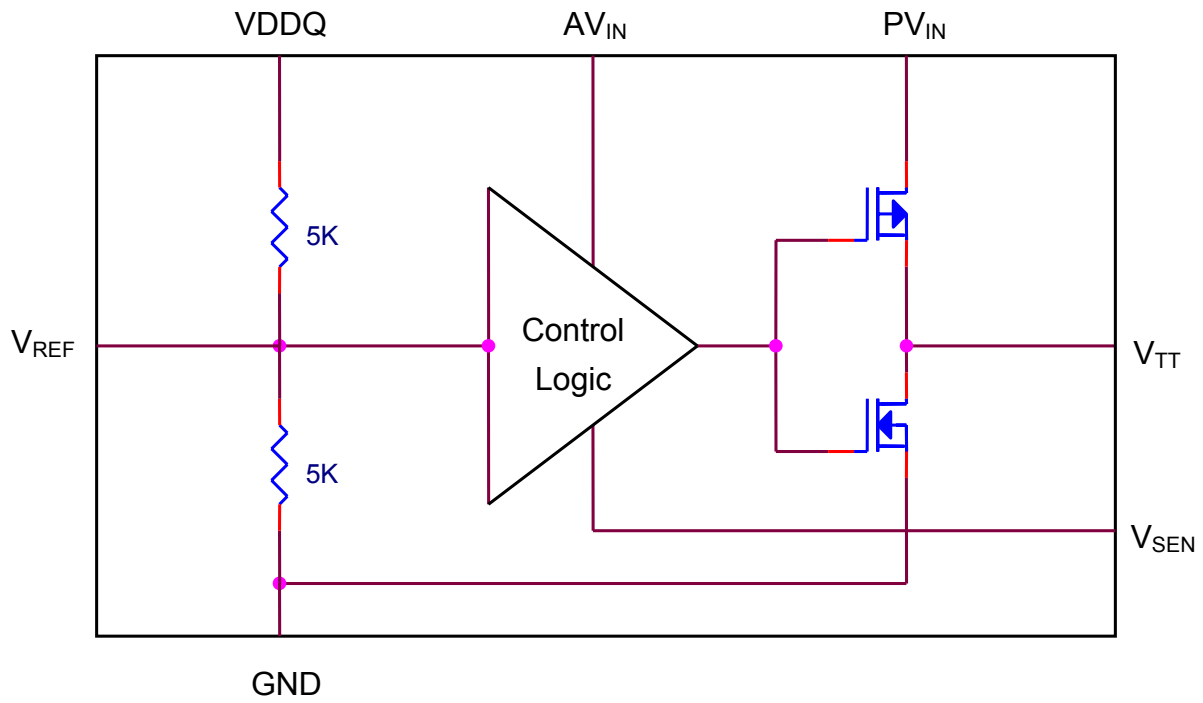



7. ELECTRICAL CHARACTERISTICS

AC CHARACTERISTICS

W83310S-R						
VIN=2.5V,VCNTL=3.3V,VREF=1.25V,Cout=100uF, TA = 0°C to +70°C						
Parameter	Symbol	Min	Typ	Max	Units	Test Conditions
Output Offset Voltage	V <sub>OS</sub>	-5	0	+5	mV	I <sub>OUT</sub> =0A
Load Regulation			0.8		%	Loading: 0A→1.5A
			0.8			Loading: 0A→-1.5A
Input Voltage Range	V <sub>IN</sub>		2.5		V	
	V <sub>CNTL</sub>		3.3			
Operating Current of VCNTL	I <sub>CNTL</sub>		0.5	1	mA	No Load(I <sub>OUT</sub> =0A)
Shutdown Threshold Trigger		0.4			V	Output=High
				0.1	V	Output=Low
Shutdown Current	I <sub>SHDN</sub>		10		uA	VREF<0.2V Loading=0.7A

Note: Load regulation is tested with a 10ms pulse current and measuring V<sub>OUT</sub>.

W83310S-N						
AVIN=3.3V; PVIN=2.5V is recommended, VDDQ =2.5V,VREF=1.25V,Cout=100uF, TA = 0°C to +70°C						
Parameter	Symbol	Min	Typ	Max	Units	Test Conditions
Output Offset Voltage	V <sub>OS</sub>	-5	0	+5	mV	I <sub>OUT</sub> =0A
Load Regulation			0.8		%	Loading: 0A→1.5A
			0.8			Loading: 0A→-1.5A
Input Voltage Range	VDDQ		2.5		V	
	PVIN		2.5			
	AVIN		3.3			
Operating Current of AVIN	I <sub>AVIN</sub>		0.5	1	mA	No Load(I <sub>OUT</sub> =0A)

Note: Load regulation is tested with a 10ms pulse current and measuring V<sub>TT</sub>.

## 8. TYPICAL OPERATING WAVEFORM

W83310S-R  $V_{OUT}$  offset with a 1.5A/10ms driving pulse current.

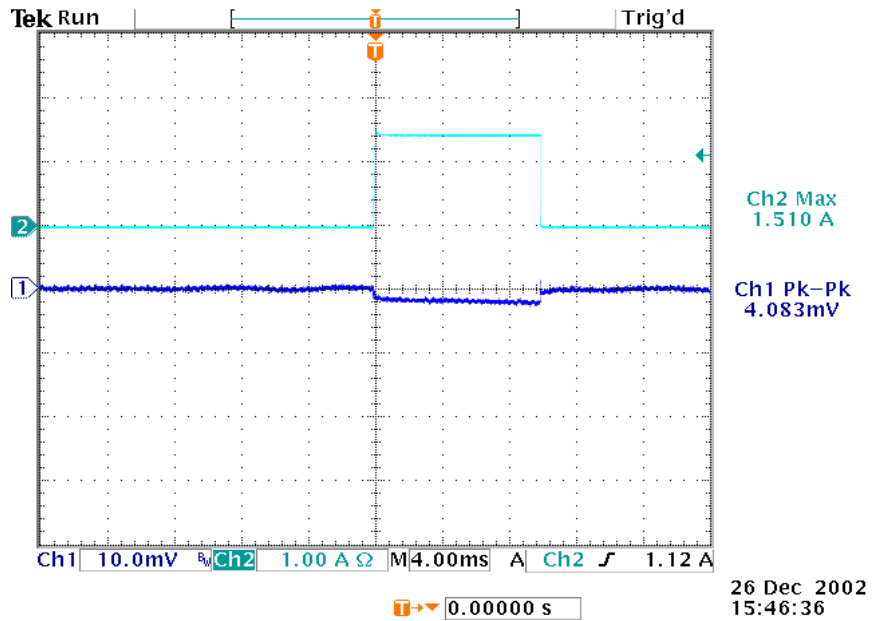

W83310S-R  $V_{OUT}$  offset with a 1.5A/10ms sinking pulse current.

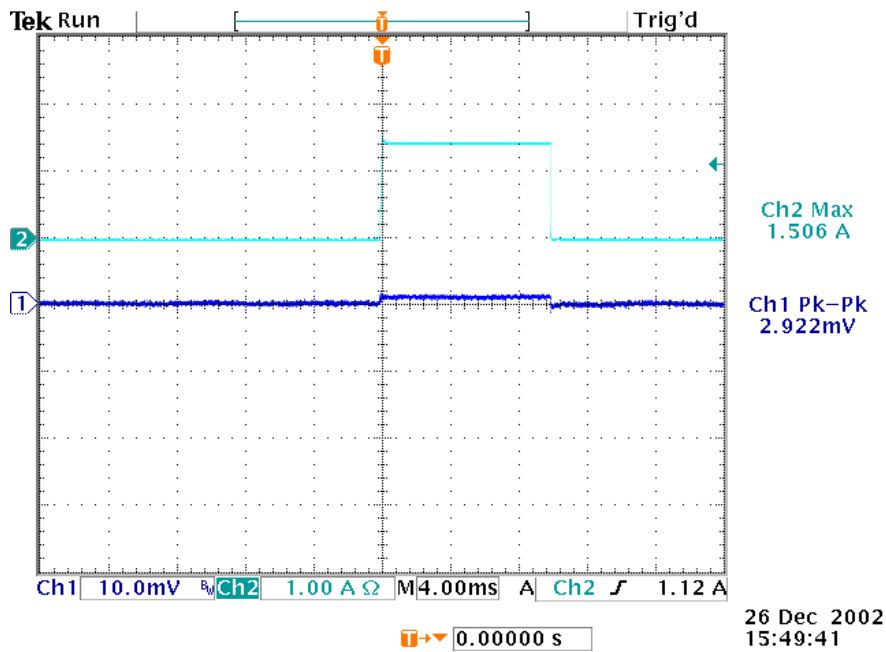

W83310S-N  $V_{TT}$  offset with a 1.5A/10ms driving pulse current.

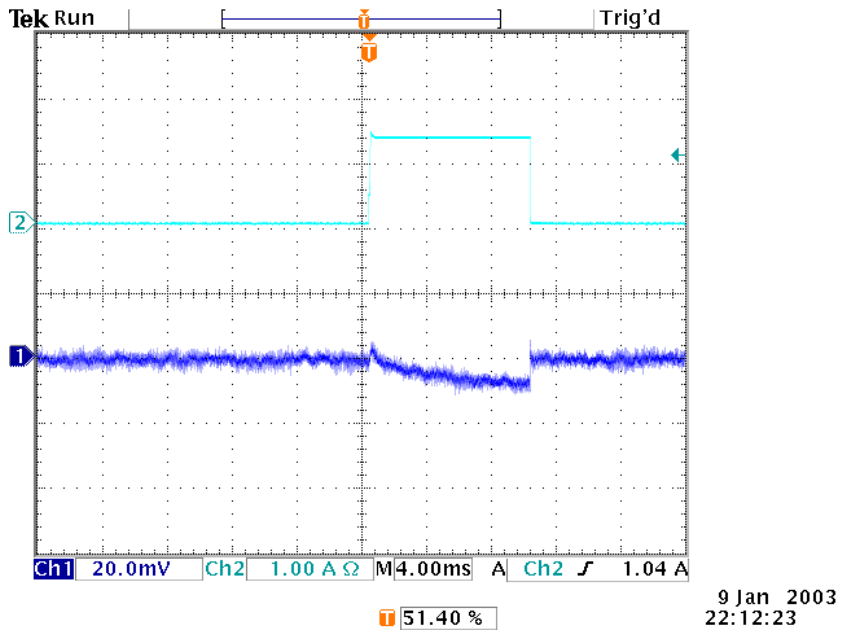

W83310S-N  $V_{TT}$  offset with a 1.5A/10ms sinking pulse current.

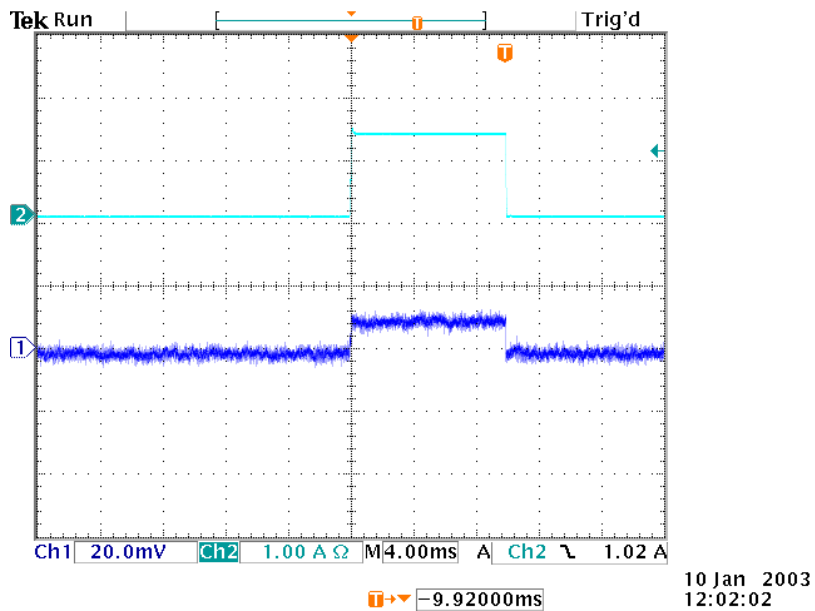



- Load regulation with various sinking/driving loading

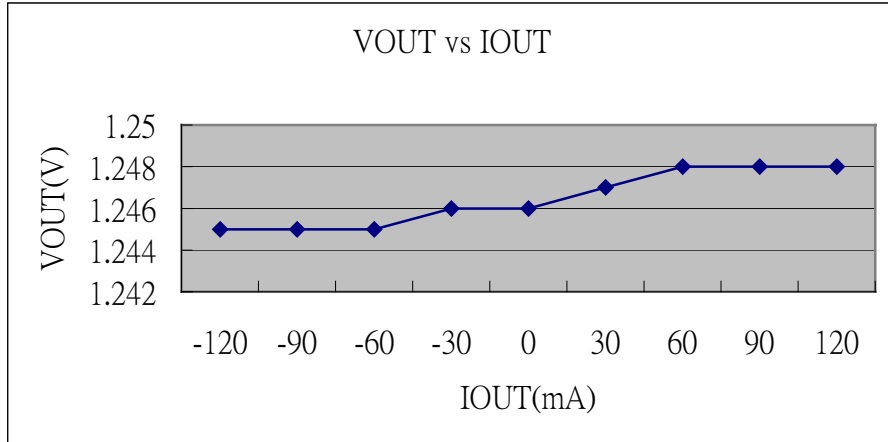

**9. PACKAGE DIMENSION**

**8L SOP 150mil**

SOP-8 Thermal Resistance  $\theta_{JA}$

156.0°C/W with 0m/s airflow  
 141.8°C/W with 1m/s airflow  
 135.2°C/W with 2m/s airflow  
 130.6°C/W with 0m/s airflow

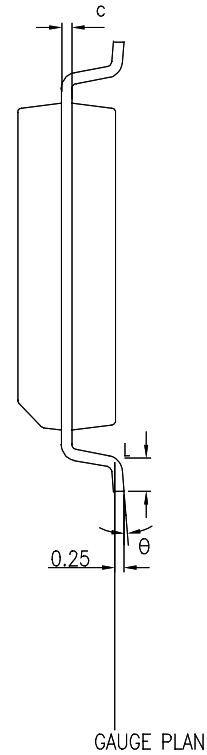
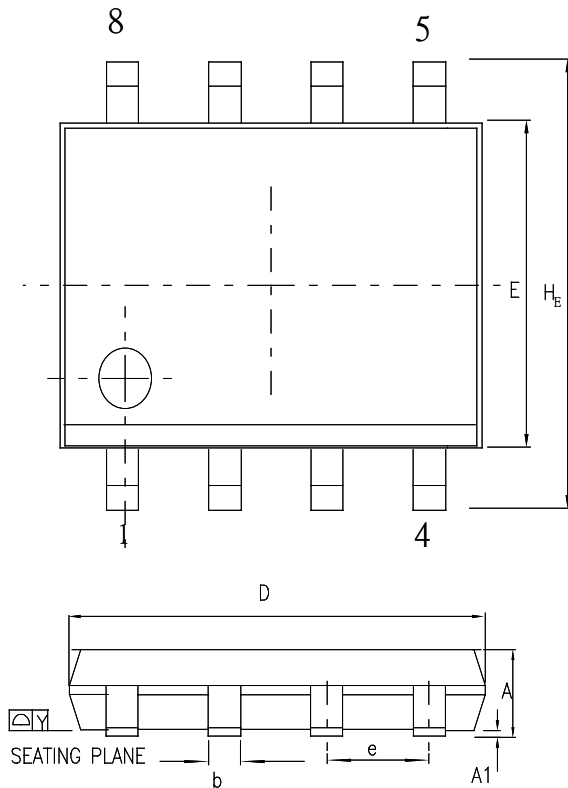

Control dimensions are in milimeters .

SYMBOL	DIMENSION IN MM		DIMENSION IN INCH	
	MIN.	MAX.	MIN.	MAX.
A	1.35	1.75	0.053	0.069
A1	0.10	0.25	0.004	0.010
b	0.33	0.51	0.013	0.020
c	0.19	0.25	0.008	0.010
E	3.80	4.00	0.150	0.157
D	4.80	5.00	0.188	0.196
e	1.27 BSC		0.050 BSC	
H <sub>E</sub>	5.80	6.20	0.228	0.244
Y	0.10		0.004	
L	0.40	1.27	0.016	0.050
θ	0	10	0	10



## 10. ORDERING INFORMATION

PART NUMBER	PACKAGE TYPE	PRODUCTION FLOW
W83310S-R	8PIN SOP	Commercial, 0°C to +70°C
W83310S-N	8PIN SOP	Commercial, 0°C to +70°C

## 11. HOW TO READ THE TOP MARKING



Left line: Winbond logo

1<sup>st</sup> & 2<sup>nd</sup> line: W883310S-R/N – the part number

3rd line: Tracking code Tracking code 249 O A

**249**: packages assembled in Year 02', week 49

**O**: assembly house ID; O means OSE, G means GR, etc.

**B**: the IC version



**Headquarters**  
No. 4, Creation Rd. III,  
Science-Based Industrial Park,  
Hsinchu, Taiwan  
TEL: 886-3-5770066  
FAX: 886-3-5665577  
<http://www.winbond.com.tw/>

**Taipei Office**  
9F, No.480, Rueiguang Rd.,  
Neihu District, Taipei, 114,  
Taiwan, R.O.C.  
TEL: 886-2-8177-7168  
FAX: 886-2-8751-3579

**Winbond Electronics Corporation America**  
2727 North First Street, San Jose,  
CA 95134, U.S.A.  
TEL: 1-408-9436666  
FAX: 1-408-5441798

**Winbond Electronics Corporation Japan**  
7F Daini-ueno BLDG, 3-7-18  
Shinyokohama Kohoku-ku,  
Yokohama, 222-0033  
TEL: 81-45-4781881  
FAX: 81-45-4781800

**Winbond Electronics (Shanghai) Ltd.**  
27F, 2299 Yan An W. Rd. Shanghai,  
200336 China  
TEL: 86-21-62365999  
FAX: 86-21-62365998

**Winbond Electronics (H.K.) Ltd.**  
Unit 9-15, 22F, Millennium City,  
No. 378 Kwun Tong Rd.,  
Kowloon, Hong Kong  
TEL: 852-27513100  
FAX: 852-27552064

*Please note that all data and specifications are subject to change without notice.  
All the trade marks of products and companies mentioned in this data sheet belong to their respective owners.*

**Please note that all data and specifications are subject to change without notice. All the trade marks of products and companies mentioned in this data sheet belong to their respective owners.**

**These products are not designed for use in life support appliances, devices, or systems where malfunction of these products can reasonably be expected to result in personal injury. Winbond customers using or selling these products for use in such applications do so at their own risk and agree to fully indemnify Winbond for any damages resulting from such improper use or sale.**