

RF Power Detector with Buffered Output and >40dB Dynamic Range

October 2001

FEATURES

- Internal Schottky Diode RF Detector with Two Power Ranges:
 - LTC5505-1, -28dBm to 18dBm
 - LTC5505-2, -32dBm to 12dBm
- Wide Input Frequency Range: 300MHz to 3GHz
- Temperature Compensated
- Buffered Detector Output
- Wide V_{CC} Range of 2.7V to 6V Allows Direct Connection to Battery
- Low Operating Current: 0.5mA
- Low Shutdown Current: <2 μ A
- Low Profile (1mm) ThinSOT™ Package

APPLICATIONS

- Multimode Mobile Phone Products
- PCS Devices
- Wireless Data Modems
- Wireless and Cable Infrastructure
- RF Power Alarm
- Envelope Detector

DESCRIPTION

The LTC®5505-X is an RF power detector for RF applications operating in the 300MHz to 3GHz range. A temperature compensated Schottky diode peak detector and buffer amplifier are combined in a small 5-pin ThinSOT package. The supply voltage range is optimized for operation from a single lithium-ion cell or 3xNiMH.

The RF input voltage is peak detected using an on-chip Schottky diode. The detected voltage is buffered and supplied to the V_{OUT} pin. A power saving shutdown mode reduces supply current to less than 2 μ A.

The LTC5505-1 operates with input power levels from -28dBm to 18dBm. The LTC5505-2 operates with input power levels from -32dBm to 12dBm.

LT, LTC and LT are registered trademarks of Linear Technology Corporation. ThinSOT is a trademark of Linear Technology Corporation

TYPICAL APPLICATION

Dual Band Mobile Phone Tx Power Control

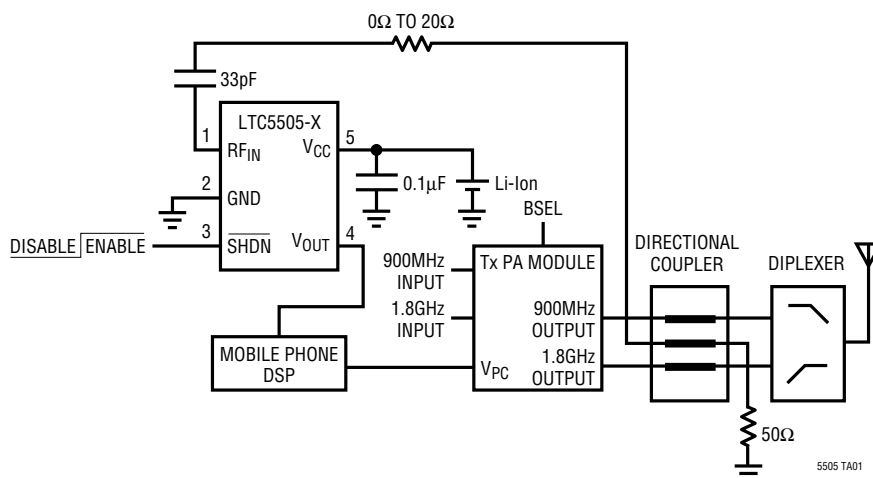

ABSOLUTE MAXIMUM RATINGS

(Note 1)

V_{CC} , V_{OUT} to GND	-0.3V to 6.5V
RF Voltage	
LTC5505-1	$(V_{CC} - 2.6V)$ to 7V
LTC5505-2	$(V_{CC} - 1.4V)$ to 7V
SHDN Voltage to GND	-0.3V to $(V_{CC} + 0.3V)$
I_{VOUT}	5mA
Operating Temperature Range (Note 2) ..	-40°C to 85°C
Maximum Junction Temperature	125°C
Storage Temperature Range	-65°C to 150°C
Lead Temperature (Soldering, 10 sec).....	300°C

PACKAGE/ORDER INFORMATION

	ORDER PART NUMBER
	LTC5505-1ES5 LTC5505-2ES5
	S5 PART MARKING
	LTXV LTRW

Consult LTC Marketing for parts specified with wider operating temperature ranges.

ELECTRICAL CHARACTERISTICS The ● denotes the specifications which apply over the full operating temperature range, otherwise specifications are at $T_A = 25^\circ\text{C}$. $V_{CC} = 3.6\text{V}$, $\overline{\text{SHDN}} = V_{CC} = \text{HI}$, $\overline{\text{SHDN}} = 0\text{V} = \text{LO}$, RF Input Signal is Off, unless otherwise noted.

PARAMETER	CONDITIONS	MIN	TYP	MAX	UNITS
V_{CC} Operating Voltage		● 2.7		6	V
I_{VCC} Shutdown Current	$\overline{\text{SHDN}} = \text{LO}$	●		2	μA
I_{VCC} Operating Current	$\overline{\text{SHDN}} = \text{HI}$, $I_{VOUT} = 0\text{mA}$	●	0.5	0.75	mA
V_{OUT} V_{OL} (No RF Input)	$R_{LOAD} = 2\text{k}$, $\overline{\text{SHDN}} = \text{HI}$, Enabled $\overline{\text{SHDN}} = \text{LOW}$, Disabled	170	260 1	350	mV mV
V_{OUT} Output Current	$V_{OUT} = 1.75\text{V}$, $V_{CC} = 2.7\text{V}$, $\Delta V_{OUT} = 10\text{mV}$	● 1	2		mA
V_{OUT} Enable Time	$\overline{\text{SHDN}} = \text{HI}$, $C_{LOAD} = 33\text{pF}$, $R_{LOAD} = 2\text{k}$	●	8	20	μs
V_{OUT} Bandwidth	$C_{LOAD} = 33\text{pF}$, $R_{LOAD} = 2\text{k}$ (Note 4)		4		MHz
V_{OUT} Load Capacitance	(Note 7)	●		33	pF
V_{OUT} Slew Rate	$V_{RFIN} = 2\text{V Step}$, $C_{LOAD} = 33\text{pF}$, $R_{LOAD} = 2\text{k}$ (Note 3)		10		V/ μs
V_{OUT} Noise	$V_{CC} = 3\text{V}$, Noise BW = 1.5MHz, 50 Ω RF Input Termination		1.4		mV _{P-P}
$\overline{\text{SHDN}}$ Voltage, Chip Disabled	$V_{CC} = 2.7\text{V}$ to 6V	●		0.35	V
$\overline{\text{SHDN}}$ Voltage, Chip Enabled	$V_{CC} = 2.7\text{V}$ to 6V	●	1.4		V
$\overline{\text{SHDN}}$ Input Current	$\overline{\text{SHDN}} = 3.6\text{V}$	●	24	40	μA

ELECTRICAL CHARACTERISTICS The ● denotes the specifications which apply over the full operating temperature range, otherwise specifications are at $T_A = 25^\circ\text{C}$. $V_{CC} = 3.6\text{V}$, $\overline{\text{SHDN}} = V_{CC} = \text{HI}$, $\overline{\text{SHDN}} = 0\text{V} = \text{LO}$, RF Input Signal is Off, unless otherwise noted.

PARAMETER	CONDITIONS	MIN	TYP	MAX	UNITS
RF _{IN} Input Frequency Range			300 to 3000		MHz
RF _{IN} Input Power Range (LTC5505-1)	RF Frequency = 900MHz (Note 5, 6, 7) $V_{CC} = 2.7\text{V to }6\text{V}$ RF Frequency = 1800MHz (Note 5, 6, 7) $V_{CC} = 2.7\text{V to }6\text{V}$ RF Frequency = 2400MHz (Note 5, 7) $V_{CC} = 2.7\text{V to }6\text{V}$ RF Frequency = 2700MHz (Note 5, 7) $V_{CC} = 2.7\text{V to }6\text{V}$		-28 to 18 -26 to 18 -24 to 16 -22 to 16		dBm dBm dBm dBm
RF _{IN} Input Power Range (LTC5505-2)	RF Frequency = 900MHz (Note 5) RF Frequency = 1800MHz (Note 5) RF Frequency = 2400MHz (Note 5) RF Frequency = 2700MHz (Note 5)		-32 to 12 -32 to 12 -32 to 12 -30 to 12		dBm dBm dBm dBm
RF _{IN} AC Input Resistance (LTC5505-1)	F = 850MHz F = 1850MHz		165 20		Ω Ω
RF _{IN} Input Shunt Capacitance (LTC5505-1)			2		pF
RF _{IN} AC Input Resistance (LTC5505-2)	F = 850MHz F = 1850MHz		165 59		Ω Ω
RF _{IN} Input Shunt Capacitance (LTC5505-2)			1.3		pF

Note 1: Absolute Maximum Ratings are those values beyond which the life of a device may be impaired.

Note 2: Specifications over the -40°C to 85°C operating temperature range are assured by design, characterization and correlation with statistical process controls.

Note 3: The rise time at V_{OUT} is measured between 0.5V and 1.5V.

Note 4: Bandwidth is calculated using the 10% to 90% rise time equation: $\text{BW} = 0.35/\text{rise time}$.

Note 5: RF performance is tested at:

1800MHz, 14dBm, -14dBm (LTC5505-1)

1800MHz, 12dBm, -14dBm (LTC5505-2)

Note 6: For input RF power levels >16dBm, V_{CC} minimum is 3V and an RF input series resistor of 20Ω is required to limit the input current.

Note 7: Guaranteed by design.

TYPICAL PERFORMANCE CHARACTERISTICS

LTC5505-1 Typical Detector Characteristics, 0.85GHz

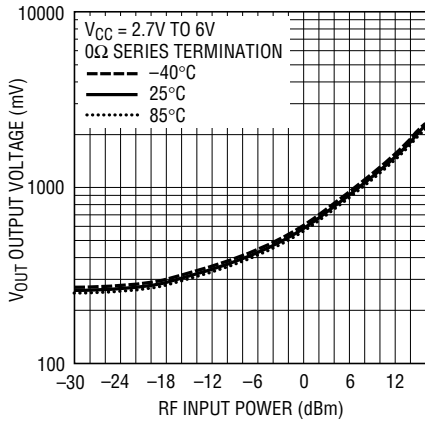

5505 G01

LTC5505-1 Typical Detector Characteristics, 1.85GHz

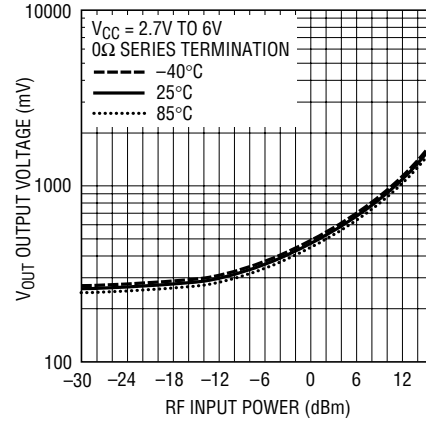

5505 G02

LTC5505-1 Typical Detector Characteristics, 2.45GHz

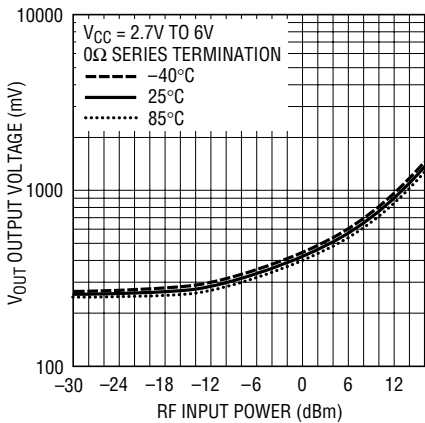

5505 G03

LTC5505-2 Typical Detector Characteristics, 0.85GHz

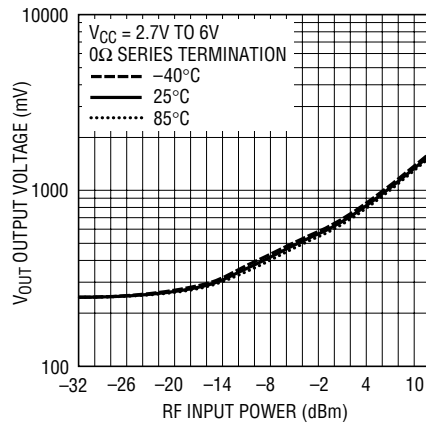

5505 G04

LTC5505-2 Typical Detector Characteristics, 1.85GHz

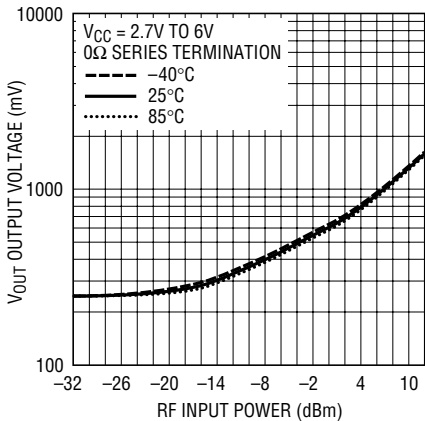

5505 G05

LTC5505-2 Typical Detector Characteristics, 2.45GHz

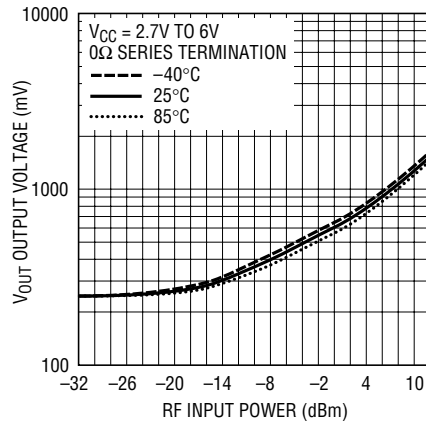

5505 G06

PIN FUNCTIONS

RF_{IN} (Pin 1): RF Feedback Voltage from the Directional Coupler. Referenced to V_{CC}. A coupling capacitor of 33pF must be used to connect to the ground referenced directional coupler. The frequency range is 300MHz to 3GHz. This pin has an internal 250Ω termination, an internal Schottky diode detector and peak detector capacitor. (See Note 6 in the Electrical Characteristics.)

GND (Pin 2): System Ground.

SHDN (Pin 3): Shutdown Input. A logic low on the SHDN pin places the part in shutdown mode. A logic high enables the part. SHDN has an internal 150k pull down resistor to ensure that the part is in shutdown when the drivers are in a tri-state condition.

V_{OUT} (Pin 4): Buffered and Level Shifted Detector Output Voltage.

V_{CC} (Pin 5): Power Supply Voltage, 2.7V to 6V. V_{CC} should be bypassed with 0.1μF and 100pF ceramic capacitors.

BLOCK DIAGRAM

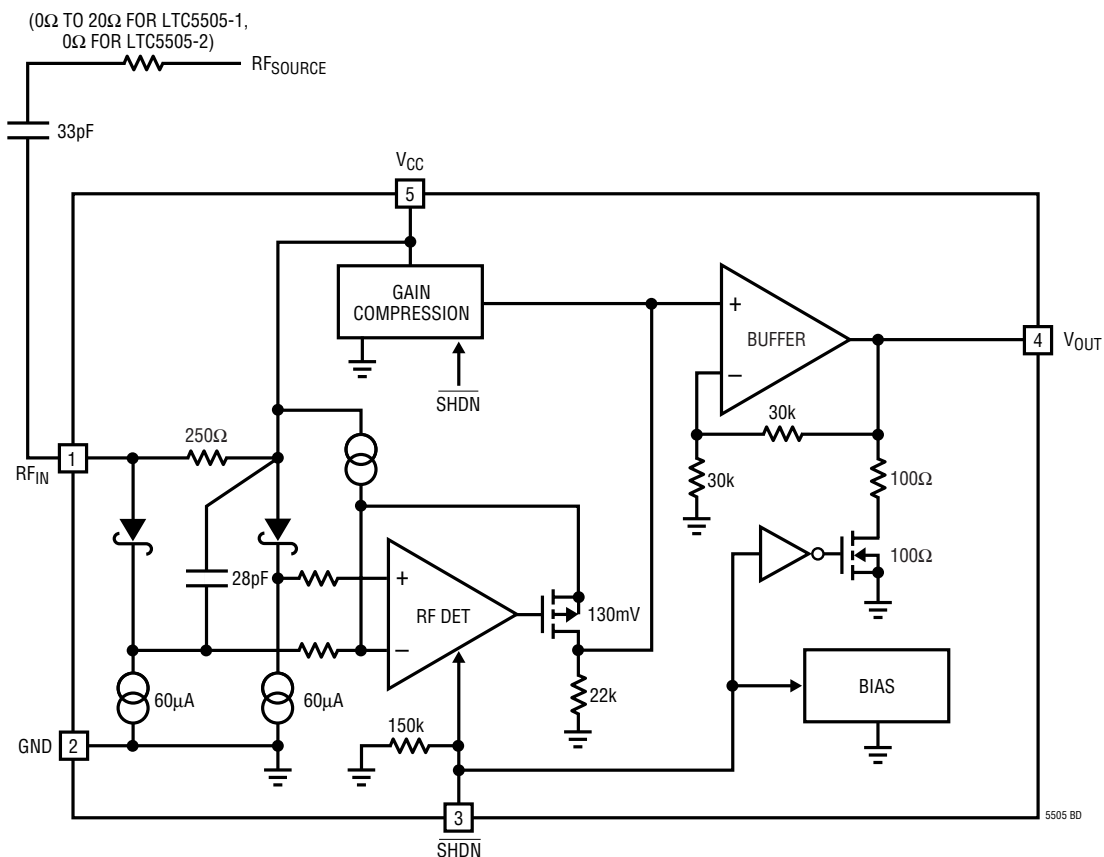

APPLICATIONS INFORMATION

Operation

The LTC5505-X RF detector integrates several functions to provide RF power detection over frequencies ranging from 300MHz to 3GHz. These functions include an internally compensated buffer amplifier, an RF Schottky diode peak detector and level shift amplifier to convert the RF feedback signal to DC, a delay circuit to avoid voltage transients at V_{OUT} when coming out of shutdown and a gain compression circuit to extend the detector dynamic range.

Buffer Amplifier

The buffer amplifier has a gain of two and is capable of driving a 2mA load. The buffer amplifier typically has an output voltage range of 0.25V to 1.75V.

RF Detector

The internal RF Schottky diode peak detector and level shift amplifier converts the RF input signal to a low frequency signal. The RF pin input resistance is typically 250 Ω and the frequency range of this pin is 300MHz to 3GHz. The detector demonstrates excellent efficiency and linearity over a wide range of input power. The Schottky detector is biased at about 60 μ A and drives a peak detector capacitor of 28pF.

Gain Compression

The gain compression circuit changes the feedback ratio as the RF peak-detected input voltage increases above

100mV. Below 100mV, the voltage gain from the peak detector to the buffer output is 1.5. Above 200mV, the voltage gain is reduced to 0.7. The compression expands the low power detector range due to higher gain.

Modes of Operation

MODE	$\overline{\text{SHDN}}$	OPERATION
Shutdown	Low	Disabled
Enable	High	Power Detect

Applications

The LTC5505-1 and LTC5505-2 can be used as self-standing signal strength measuring receivers for a wide range of input signals from -32dBm to 18dBm for frequencies from 300MHz to 3GHz.

The LTC5505-1 and LTC5505-2 can be used as demodulators for AM and ASK modulated signals with data rates up to 5MHz. Depending on specific application needs, the RSSI output can be split into two branches, providing AC-coupled data (or audio) output and DC-coupled, RSSI output for signal strength measurements and AGC.

For the LTC5505-1, a resistor in the range of 0 Ω to 20 Ω can be placed in series with the RF input to shift the operating range to higher power. A resistor of 20 Ω is required for GSM/DCS mobile phone Tx power control, in conjunction with a dual directional coupler at the Tx PA outputs.

Example of LTC5505-X GSM/DCS Power Control Timing Diagram

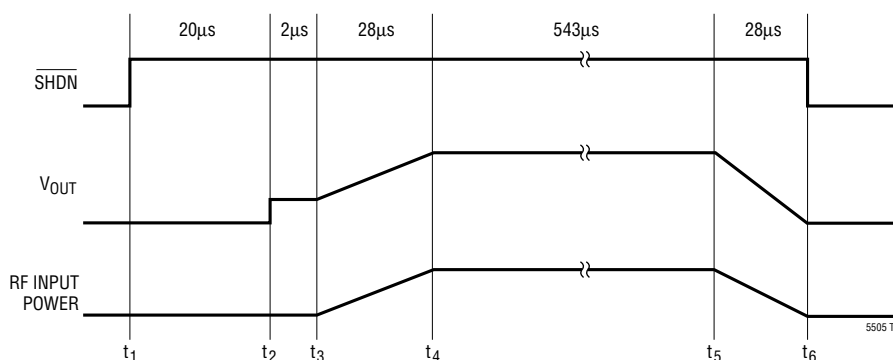

t_1 : PART COMES OUT OF SHUTDOWN 20 μ s MAXIMUM PRIOR TO BURST.

t_2 : CIRCUITS POWER UP AND SETTLE.

t_3 : BASEBAND CONTROLLER STARTS RF POWER RAMP UP AT 22 μ s AFTER $\overline{\text{SHDN}}$ IS ASSERTED HIGH.

t_4 : BASEBAND CONTROLLER COMPLETES RAMP UP.

t_5 : BASEBAND CONTROLLER STARTS RF POWER RAMP DOWN AT END OF BURST.

t_6 : LTC5505-X RETURNS TO SHUTDOWN MODE BETWEEN BURSTS

PACKAGE DESCRIPTION

S5 Package 5-Lead Plastic SOT-23

(Reference LTC DWG # 05-08-1633)

(Reference LTC DWG # 05-08-1635)

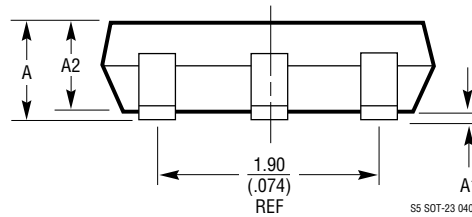
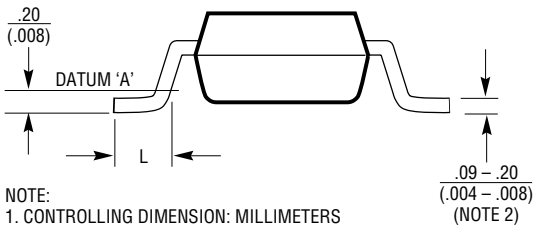
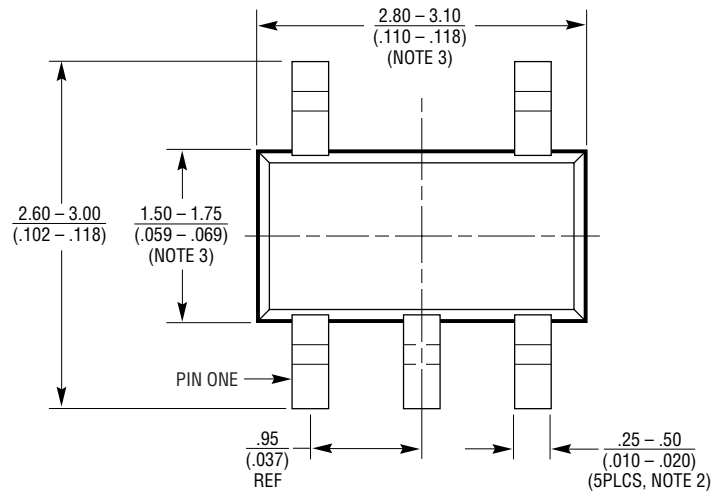

- NOTE:
1. CONTROLLING DIMENSION: MILLIMETERS
 2. DIMENSIONS ARE IN MILLIMETERS (INCHES)
 3. DRAWING NOT TO SCALE
 4. DIMENSIONS ARE INCLUSIVE OF PLATING
 5. DIMENSIONS ARE EXCLUSIVE OF MOLD FLASH AND METAL BURR
 6. MOLD FLASH SHALL NOT EXCEED .254mm
 7. PACKAGE EIAJ REFERENCE IS:
SC-74A (EIAJ) FOR ORIGINAL
JEDEL MO-193 FOR THIN

	SOT-23 (Original)	SOT-23 (ThinSOT)
A	.90 - 1.45 (.035 - .057)	1.00 MAX (.039 MAX)
A1	.00 - .15 (.00 - .006)	.01 - .10 (.0004 - .004)
A2	.90 - 1.30 (.035 - .051)	.80 - .90 (.031 - .035)
L	.35 - .55 (.014 - .021)	.30 - .50 REF (.012 - .019 REF)

RELATED PARTS

PART NUMBER	DESCRIPTION	COMMENTS
RF Power Controllers		
LTC1757A	RF Power Controller	Single/Dual Band GSM/DCS/GPRS Mobile Phones
LTC1758	RF Power Controller	Single/Dual Band GSM/DCS/GPRS Mobile Phones
LTC1957	RF Power Controller	Single/Dual Band GSM/DCS/GPRS Mobile Phones
LTC4400	SOT-23 RF PA Controller	Single/Dual Band GSM/DCS/GPRS Phones, 45dB Dynamic Range, 450kHz Loop BW
LTC4401	SOT-23 RF PA Controller	Single/Dual Band GSM/DCS/GPRS Phones, 45dB Dynamic Range, 250kHz Loop BW
Other Related Parts		
LTC1503	Inductorless Step-Down DC/DC Converter	600kHz, Up to 100mA, 25% Higher Efficiency than Linear Regulator
LTC1555L-1.8	SIM Power Supply and Level Translator	Generates 1.8V, 3V or 5V; >10kV ESD on All SIM Contact Pins
LT [®] 1615	Step-Up DC/DC Converter	ThinSOT, Low 20 μ A Quiescent Current, V_{IN} as Low as 1V, 300mA I_{OUT}
LT1617	Inverting DC/DC Converter	ThinSOT, Low 20 μ A Quiescent Current, V_{IN} as Low as 1V, 300mA I_{OUT}
LTC1682	Low Noise Charge Pump with LDO	60 μ V _{RMS} Output Noise, Small MSOP Package
LT1761	Low Dropout, Low Noise Linear Regulator	ThinSOT, 300mV Dropout at 100mA, 20 μ V _{RMS} Output Noise (10Hz to 100kHz)
LTC1878	Step-Down DC/DC Converter	Integrated Synchronous Operation, Up to 95% Efficiency, 1A Switch Current
LTC1928	Low Noise Charge Pump	ThinSOT, 90 μ V _{RMS} Output Noise (100kHz BW), I_{OUT} Up to 30mA
LT1932	White LED Driver	ThinSOT, 1.2MHz DC/DC Constant-Current LED Driver, Dimming Control
LT1944	Step-Up DC/DC Converter	Dual Output for LCD Bias, Low Quiescent Current of 20 μ A, 1.2V $\leq V_{IN} \leq 15V$
LTC1986	SIM Power Supply	ThinSOT, 3V and 5V, Ultralow Supply Current of 14 μ A, <0.92cm ² PCB
LTC3200	Low Noise Charge Pump	2MHz Switching Frequency Allows Small Size Capacitors, I_{OUT} Up to 100mA
LTC3401	Step-Up DC/DC Converter	Synchronous Rectification, Up to 97% Efficiency, 1A Switch Current, 3MHz
LTC3402	Step-Up DC/DC Converter	Synchronous Rectification, Up to 97% Efficiency, 2A Switch Current, 3MHz
LTC3404	Step-Down DC/DC Converter	1.4MHz Synchronous Rectification, 10 μ A Quiescent Current