



Description

The MK3805 is a non-inverting clock driver/buffer providing two independent banks of four outputs each. These buffers have a tri-state output enable input (active low) with 1-input, 5-output configuration per group. The skew between the outputs of the same package is 0.5 ns and the skew between the outputs of different packages is 0.8 ns. The maximum input to output delay is 4.5 ns.

Features

- Packaged in 20-pin SSOP
- Five outputs for each bank with one clock input
- Two separate banks of five outputs each
- Advanced, low-power, CMOS process
- Ten output clocks
- Two separate inputs
- Industrial temperature range -40°C to +85°C
- Hysteresis on all inputs

Block Diagram

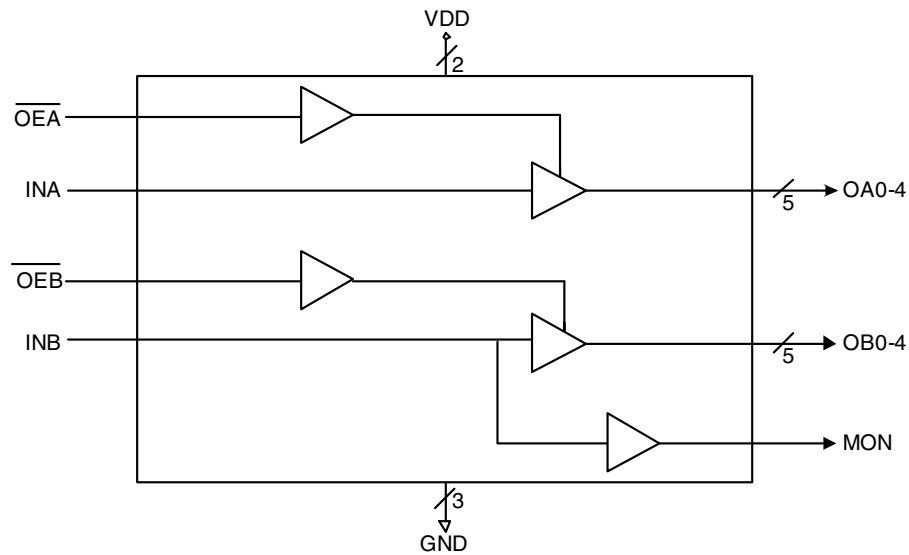



Pin Assignment

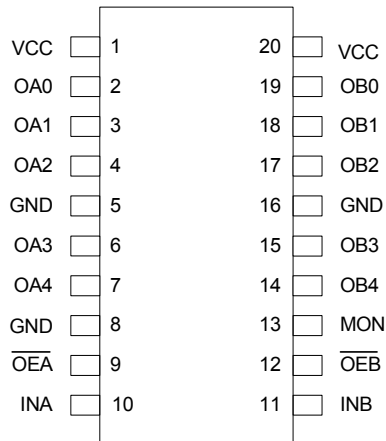

20 pin (150 mil) SSOP/20 pin (300mil) SOIC

Truth Table

Inputs		Outputs	
\overline{OEA} , \overline{OEB}	INA, INB	OAN, OBN	MON
L	L	L	L
L	H	H	H
H	L	Z	L
H	H	Z	H

Pin Descriptions

Pin Number	Pin Name	Pin Type	Pin Description
1	VCC	Power	Connect to +3.3 V
2	OA0	Output	Clock output.
3	OA1	Output	Clock output.
4	OA2	Output	Clock output.
5	GND	Power	Connect to ground.
6	OA3	Output	Clock output.
7	OA4	Output	Clock output.
8	GND	Power	Connect to ground.
9	\overline{OEA}	Input	Tri state output enable input (active low).
10	INA	Input	Clock input.
11	INB	Input	Clock input.
12	\overline{OEB}	Input	Tri state output enable input (active low).
13	MON	Output	Monitor output.
14	OB4	Output	Clock output.
15	OB3	Output	Clock output.
16	GND	Power	Connect to ground.
17	OB2	Output	Clock output.
18	OB1	Output	Clock output.
19	OB0	Output	Clock output.
20	VCC	Power	Connect to +3.3 V



External Components

The MK3805 requires a minimum number of external components for proper operation.

Decoupling Capacitors

Decoupling capacitors of 0.01 μ F must be connected between VDD and GND, as close to these pins as possible. For optimum device performance, the decoupling capacitors should be mounted on the component side of the PCB. Avoid the use of vias in the decoupling circuit.

Series Termination Resistor

When the PCB trace between the clock outputs and the loads are over 1 inch, series termination should be used. To series terminate a 50 Ω trace (a commonly used trace impedance) place a 33 Ω resistor in series with the clock line, as close to the clock output pin as possible. The nominal impedance of the clock output is 20 Ω .

PCB Layout Recommendations

For optimum device performance and lowest output phase noise, the following guidelines should be observed.

- 1) The 0.01 μ F decoupling capacitors should be mounted on the component side of the board as close to the VDD pins as possible. No vias should be used between the decoupling capacitors and VDD pins. The PCB trace to VDD pin should be kept as short as possible, as should the PCB trace to the ground via.
- 2) To minimize EMI, the 33 Ω series termination resistor (if needed) should be placed close to the clock output.
- 3) An optimum layout is one with all components on the same side of the board, minimizing vias through the signal layers. Other signal traces should be routed away from the MK3805. This includes signal traces just underneath the device, or on layers adjacent to the ground plane layer used by the device.

Absolute Maximum Ratings

Stresses above the ratings listed below can cause permanent damage to the MK3805. These ratings, which are standard values for ICS commercially rated parts, are stress ratings only. Functional operation of the device at these or any other conditions above those indicated in the operational sections of the specifications is not implied. Exposure to absolute maximum rating conditions for extended periods can affect product reliability. Electrical parameters are guaranteed only over the recommended operating temperature range.

Item	Rating
Supply Voltage, VDD	7 V
All Inputs and Outputs	-0.5 V to VDD+0.5 V
Ambient Operating Temperature	-40 to +85°C
Storage Temperature	-65 to +150°C
Junction Temperature	125°C
Soldering Temperature	260°C



Recommended Operation Conditions

Parameter	Min.	Typ.	Max.	Units
Ambient Operating Temperature	-40		+85	°C
Power Supply Voltage (measured in respect to GND)	+3.13	+3.3	+3.46	V

DC Electrical Characteristics

Unless stated otherwise, **VDD = 3.3 V ±5%**, Ambient Temperature -40°C to +85°C

Parameter	Symbol	Conditions	Min.	Typ.	Max.	Units
Operating Voltage	VDD		3.13	3.3	3.46	V
Supply Current	IDD	No load, $\overline{OEA}, \overline{OEB}$ GND, fo=10MHz, 50% duty cycle		3.3		mA
	IDD	No load, $\overline{OEA}, \overline{OEB}$ GND, fo=2.5MHz, 50% duty cycle		1.8		mA
Quiescent Current	ICC			3	30	μA
Input High Voltage	V _{IH}		2			V
Input Low Voltage	V _{IL}				0.8	V
Output High Voltage	V _{OH}	I _{OH} = -4 mA	VDD-0.4			V
Output High Voltage	V _{OH}	I _{OH} = -12 mA	2.4			V
Output Low Voltage	V _{OL}	I _{OL} = 12 mA			0.4	V
Short Circuit Current	I _{OS}	CLK output		±50		mA
Input Capacitance				5		pF
Nominal Output Impedance	Z _O			20		Ω
Input Hysteresis	V _H			150		mV



AC Electrical Characteristics

Unless stated otherwise, $V_{DD} = 3.3\text{ V} \pm 5\%$, Ambient Temperature -40°C to $+85^{\circ}\text{C}$

Parameter	Symbol	Conditions	Min.	Typ.	Max.	Units
Skew between outputs of same package)	$t_{sk(o)}$	CL=50 pF, RL=500 Ω			0.5	ns
Skew between outputs of different packages at same temp (same transition)	$t_{sk(t)}$	CL=50 pF, RL=500 Ω			0.8	ns
Propagation Delay INA to OAN INB to OBN	t_{PLH} , t_{PHL}	CL=50 pF, RL=500 Ω	1.5		4.5	ns
Output Rise Time 0.8 V to 2.0 V	t_R	CL=50 pF, RL=500 Ω			2	ns
Output Fall Time 2.0 V to 0.8 V	t_F	CL=50 pF, RL=500 Ω			2	ns
Output Enable Time	$\overline{OE}A$ to OAN, $\overline{OE}B$ to OBN	CL=50 pF, RL=500 Ω	1.5		6.2	ns
Output Disable Time	$\overline{OE}A$ to OAN, $\overline{OE}B$ to OBN	CL=50 pF, RL=500 Ω	1.5		5.0	ns
Duty Cycle Measured at $V_{DD}/2$		CL=50 pF, RL=500 Ω	45		55	%
Operating Frequency		CL=50 pF, RL=500 Ω	1		100	MHz



Package Outline and Package Dimensions (20-pin SSOP, 150Mil. Body)

Package dimensions are kept current with JEDEC Publication No. 95

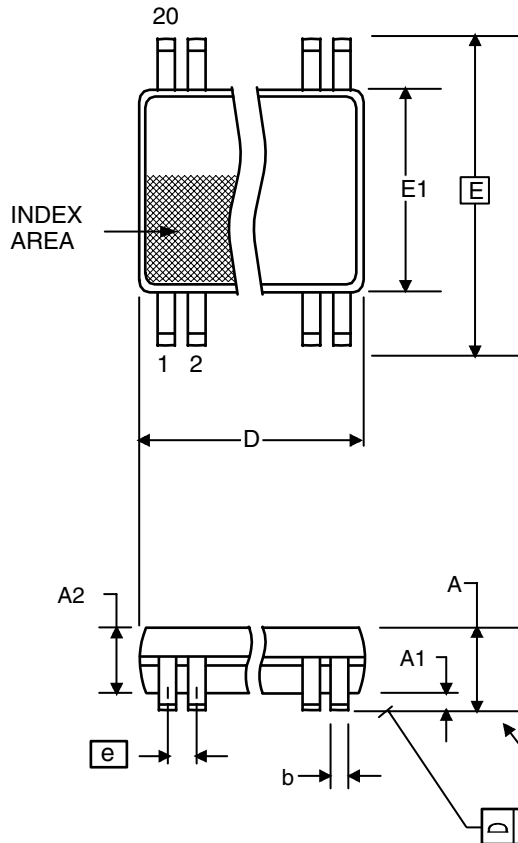

Symbol	Millimeters		Inches	
	Min	Max	Min	Max
A	1.35	1.75	.053	.069
A1	0.10	0.25	.0040	.010
A2	--	1.50	--	.059
b	0.20	0.30	0.008	0.012
C	0.18	0.25	.007	.010
D	8.55	8.75	.337	.344
E	5.80	6.20	.228	.244
E1	3.80	4.00	.150	.157
e	0.635 Basic		0.025 Basic	
L	0.40	1.27	.016	.050
α	0°	8°	0°	8°

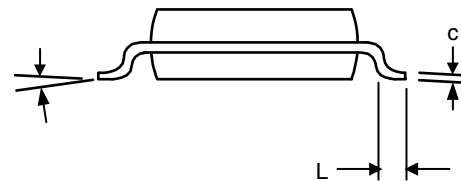

Ordering Information

Part / Order Number	Marking	Shipping packaging	Package	Temperature
MK3805RI	MK3805RI	Tubes	20-pin SSOP	-40 to +85° C
MK3805RIT	MK3805RI	Tape and Reel	20-pin SSOP	-40 to +85° C

While the information presented herein has been checked for both accuracy and reliability, Integrated Circuit Systems (ICS) assumes no responsibility for either its use or for the infringement of any patents or other rights of third parties, which would result from its use. No other circuits, patents, or licenses are implied. This product is intended for use in normal commercial applications. Any other applications such as those requiring extended temperature range, high reliability, or other extraordinary environmental requirements are not recommended without additional processing by ICS. ICS reserves the right to change any circuitry or specifications without notice. ICS does not authorize or warrant any ICS product for use in life support devices or critical medical instruments.