

PRELIMINARY
 Notice: This is not a final specification.
 some parametric limits are subject to change.

M65856SP

DIGITAL ECHO WITH MICROPHONE MIXING CIRCUIT

DESCRIPTION

The M65856 is a CMOS IC built-in Digital Echo function with microphone peripheral circuits for "Karaoke" equipment packed in a single chip.

It is suitable for "Karaoke" equipments such as Video CD Player, Mini Stereo, CD-Radio Cassette, TV or VCR.

FEATURES

- High performance digital echo circuit thanks to 16Kbit memory
- Built-in surround function which works Simulated Stereo for monaural source and Stereo Surround for stereo source
- ALC-equipped microphone amplifiers permit excessively high input. ALC operating voltage can be set as desired.
- 2 microphone volumes, echo effect volume and echo feedback volume are included
- Stereo microphone-line mixing amplifiers
- Karaoke entertainment functions such as vocal cut and automatic vocal support system
- Built-in interface terminal for external keycontrol IC
- Built-in current-control oscillation circuit
- Built-in automatic reset circuit activated with power on
- 5V single power supply

RECOMMENDED OPERATING CONDITION

- Supply voltage range $V_{CC} = 4.5 \sim 5.5V$
 Rated supply voltage $V_{CC} = 5V$

PIN CONFIGURATION

MIC SW	1	42	DATA
MCLKCONT	2	41	CLOCK
VALC	3	40	LATCH
MIC1IN	4	39	PS2
ALC1	5	38	PS1
MIC1NFIN	6	37	VCFIL
MIC1OUT	7	36	LOUT
MIC1VOLIN	8	35	ROUT
MIC2IN	9	34	SOURCEOUT
ALC2	10	33	KEYCONIN
MIC2NFIN	11	32	RIN
MIC2OUT	12	31	LIN
MIC2VOLIN	13	30	VOL IN
MICOUT	14	29	LPF2OUT
LPF1IN1	15	28	LPF2IN2
LPF1IN2	16	27	LPF2IN1
LPF1OUT	17	26	DAINTOUT
ADINTOUT	18	25	DAINTIN
ADINTIN	19	24	DACONT
ADCONT	20	23	VCC
REF	21	22	GND

SYSTEM CONFIGURATION

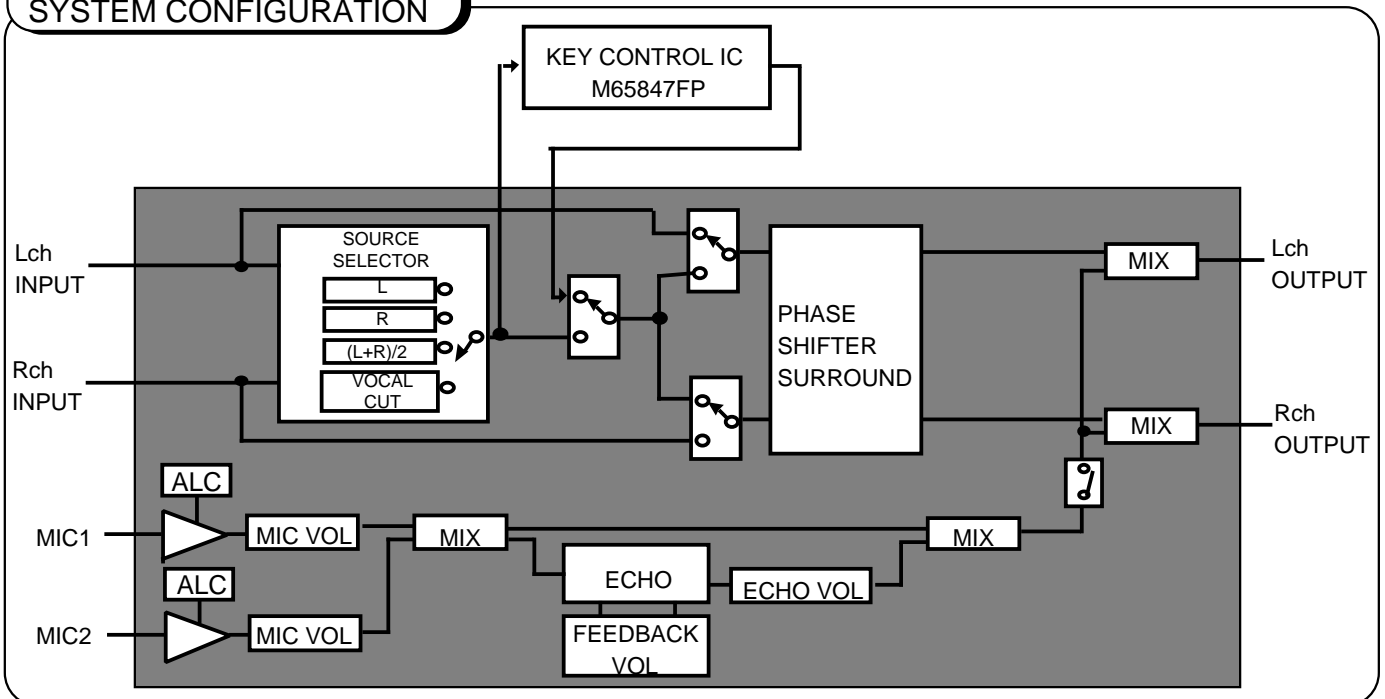

PRELIMINARY
 Notice: This is not a final specification.
 some parametric limits are subject to change.

M65856SP

DIGITAL ECHO WITH MICROPHONE MIXING CIRCUIT

PIN CONFIGURATION

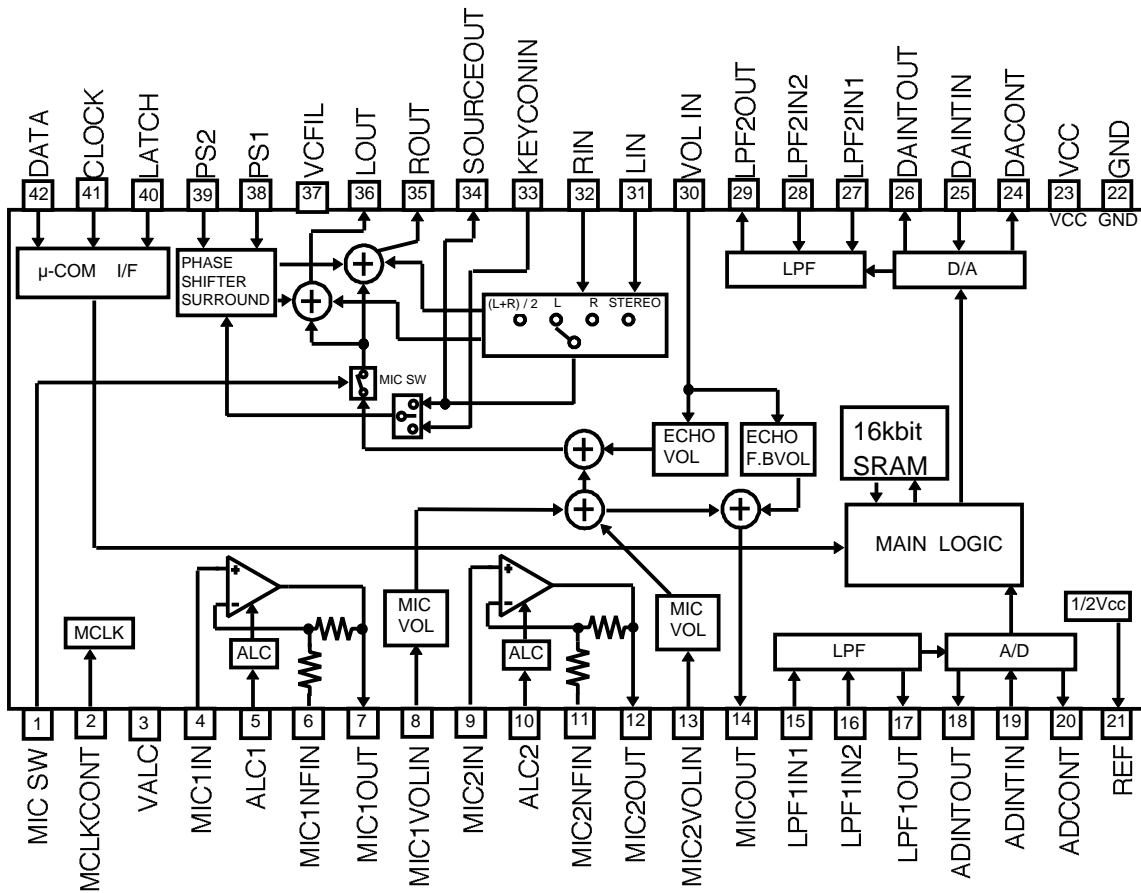

PRELIMINARY
 Notice: This is not a final specification.
 some parametric limits are subject to change.

M65856SP

DIGITAL ECHO WITH MICROPHONE MIXING CIRCUIT

PIN DESCRIPTION

Pin No.	Symbol	Name	I/O	Function
1	MIC SW	Microphone SW	I	L: MIC OFF H: MIC ON
2	MCLKCONT	Clock control	—	Controls built-in clock generation circuit with external R
3	VALC	ALC operating voltage setting terminal	—	To set ALC operating voltage according to applied voltage
4	MIC1IN	Microphone 1 input	I	To connect MIC1
5	ALC1	ALC1 control	—	To connect ALC1 attack / recovery time setting capacitor
6	MIC1NFIN	Microphone 1 negative feedback input	I	To connect low cut-off frequency of MIC1 amplifier setting capacitor
7	MIC1OUT	Microphone 1 output	O	
8	MIC1VOLIN	Microphone 1 volume input	I	To connect capacitor to reduce noise generated at time of volume change
9	MIC2IN	Microphone 2 input	I	To connect MIC2
10	ALC2	ALC2 control	—	To connect ALC2 attack/recovery time setting capacitor
11	MIC2NFIN	Microphone 2 negative feedback input	I	To connect low cut-off frequency of MIC2 amplifier setting capacitor
12	MIC2OUT	Microphone 2 input	I	
13	MIC2VOLIN	Microphone 2 volume input	I	To connect capacitor to reduce noise generated at time of volume change
14	MICOUT	Microphone output	O	Mixing output of MIC1 and MIC2
15	LPF1IN1	Low pass filter 1 input 1	I	Pre-filter before A/D convertor for digital delay
16	LPF1IN2	Low pass filter 1 input 2	I	
17	LPF1OUT	Low pass filter 1 output	O	
18	ADINTOUT	A/D integrator output	O	Composes D/A conversion integrator with external capacitor
19	ADINTIN	A/D integrator input	I	
20	ADCONT	A/D control	—	To determine adaptive time constant of A/D convertor with ADM system
21	REF	Reference power output	—	To connect 1/2 V _{cc} output and filter capacitor

PRELIMINARY
 Notice : This is not a final specification.
 some parametric limits are subject to change.

M65856SP

DIGITAL ECHO WITH MICROPHONE MIXING CIRCUIT

Pin No.	Symbol	Name	I/O	Function
22	GND	Ground	—	
23	VCC	Power supply	—	
24	DACONT	D/A control	—	To determine adaptive time constant of D/A convertor with ADM system
25	DAINTIN	D/A Integrator input	I	Composes D/A conversion integrator with external capacitor
26	DAINTOUT	D/A integrator output	O	
27	LPF2IN1	Low pass filter 2 input 1	I	Post-filter after D/A convertor for digital delay
28	LPF2IN2	Low pass filter 2 input 2	I	
29	LPF2OUT	Low pass filter 2 output	O	
30	VOLIN	Echo effect / Echo feed back volume input	I	To connect capacitor to reduce noise generated at time of volume change
31	LIN	Lch line input	I	Lch line input
32	RIN	Rch line input	I	Rch line input
33	KEYCONIN	monaural input for external KEYCONTROL IC	I	input/output interface terminal for external KEYCONTROL IC
34	SOURCEOUT	monaural output for external KEYCONTROL IC	O	
35	ROUT	Rch output	O	Rch mixing output
36	LOUT	Lch output	O	Lch mixing output
37	VCFIL	Vocal cut filter	—	Processes frequencies lower than the vocal band
38	PS1	Phase shift input 1	I	Determines a constant at time of phase shift
39	PS2	Phase shift input 2	I	
40	LATCH	LATCH	I	Latch input via serial bus
41	CLOCK	CLOCK	I	Clock input via serial bus
42	DATA	DATA	I	Data input via serial bus

PRELIMINARY
 Notice : This is not a final specification.
 some parametric limits are subject to change.

M65856SP

DIGITAL ECHO WITH MICROPHONE MIXING CIRCUIT

ELECTRICAL CHARACTERISTICS

(Vcc=5V, f=1kHz, vi=100mVrms, Ta=25°C Unless otherwise noted)

Symbol	Parameter	Test conditions	Limits			Unit		
			Min	Typ	Max			
TOTAL	Icc	Circuit current	No signal provided		-	40	88	mA
Microphone amplifier	Gvo	Amplifier gain	Vo = -17dBV		44	47	50	dB
	THD1	Distortion	Vo = -17dBV, with ALC not operated		-	0.5	1.5	%
	THD2	Distortion	Vi = -37dBV, with ALC operated		-	3.0	6.0	%
	VoALC	ALC operating voltage measurement error	measurement : -10 to +3dBV		-3	0	+3	dB
	TALCAT	ALC attack time	C=4.7μF		25	40	55	msec
	TALCRE	ALC recovery time	C=4.7μF		1.0	1.5	2.0	sec
	VoMAX	Maximum output voltage	THD=10%		1.3	1.4	-	Vrms
	No	Output noise voltage	Gv=47dB, f=100 to 5KHz		-	-68	-57	dBV
	Zi	Input impedance			5	10	20	K
Mic volume	Gv	I/O voltage gain	Volume max		-3	0	+3	dB
	ATTmax	Maximum attenuation	Volume min		-	-72	-67	dBV
	THD	Distortion	Volume max		-	0.15	0.30	%
	ViMAX	Maximum input voltage	THD=10%		1.4	1.7	-	Vrms
	No	Output noise voltage	JIS - A		-	-96	-90	dBV
Echo effect / Echo feed back volume	Gv	I/O voltage gain	Volume max		-3	0	+3	dB
	ATTmax	Maximum attenuation	Volume min		-	-72	-67	dBV
	THD	Distortion	Volume max		-	0.15	0.30	%
	VoMAX	Maximum output voltage	THD=10%		1.1	1.4	-	Vrms
	No	Output noise voltage	JIS - A		-	-96	-90	dBV

PRELIMINARY
 Notice : This is not a final specification.
 some parametric limits are subject to change.

M65856SP

DIGITAL ECHO WITH MICROPHONE MIXING CIRCUIT

Symbol	Parameter	Test conditions	Limits			Unit	
			Min	Typ	Max		
Digital echo	Gv	I/O voltage gain	-3	0	+3	dB	
	VoMAX	Maximum output voltage	THD=10%	1.1	1.4	-	Vrms
Digital echo	Td	Delay Time	Sets Delay time with microcomputer.	88.4	104.0	119.6	msec
				117.9	138.7	159.5	msec
				132.6	156.0	179.4	msec
				176.9	208.1	239.3	msec
	THD	Distortion	Td=104.0mS,30KHzLPF	-	1.0	2.0	%
			Td=138.7mS,30KHzLPF	-	1.5	3.0	%
			Td=156.0mS,30KHzLPF	-	1.5	3.0	%
			Td=208.1mS,30KHzLPF	-	2.0	4.0	%
	No	Output noise voltage	Vi=0mVrms,JIS - A Td=104.0msec,Rg=620	-	-87	-72	dBV
			Vi=0mVrms,JIS - A Td=138.7msec,Rg=620	-	-85	-70	dBV
			Vi=0mVrms,JIS - A Td=156.0msec,Rg=620	-	-85	-70	dBV
			Vi=0mVrms,JIS - A Td=208.1msec,Rg=620	-	-82	-67	dBV
LINE	Gv	I/O voltage gain	-3	0	+3	dB	
	THD	Distortion	30KHzLPF	-	0.02	0.04	%
	VoMAX	Maximum output voltage	THD=10%	1.1	1.7	-	Vrms
	No	Output noise voltage	JIS - A,MIC SW OFF	-	-95	-90	dBV
	CS	Channel separation	Lin=1kHz,Vi=1Vrms,Rout JIS - A	-	-70	-50	dB
	Zi	Input impedance		13	20	32	K
	Grej	Vocal removal ratio	Vocal cut	14	18	-	dB

PRELIMINARY
 Notice : This is not a final specification.
 some parametric limits are subject to change.

M65856SP

DIGITAL ECHO WITH MICROPHONE MIXING CIRCUIT

ABSOLUTE MAXIMUM RATINGS

Symbol	Name	Test conditions	Ratings	Units
Vcc	Supply voltage		6.0	V
Vi	Circuit current		-0.3 ~ Vcc+0.3	V
Pd	Input Voltage		1.1	W
Topr	Operating temperature		-20 ~ +75	°C
Tstg	Storage temperature		-40 ~ +125	°C

RECOMMENDED OPERATING CONDITION

Symbol	Parameter	Test conditions	Limits			Units
			Min	Typ	Max	
Vcc	Supply voltage		4.5	5	5.5	V
VIL	L input level	pin40,41,42	0	–	0.8	V
VIH	H input level	pin40,41,42	2.4	–	VDD	V

PRELIMINARY
 Notice : This is not a final specification.
 some parametric limits are subject to change.

M65856SP

DIGITAL ECHO WITH MICROPHONE MIXING CIRCUIT

FUNCTION DESCRIPTION

OPERATION MODE

Operating modes can be set with serial data 16-bits entered at the timing given below.

DATA(pin42) is taken inside at the rising edge of CLOCK(pin41) and the last-packed 16-bits are latched at the raising edge of LATCH(pin40).

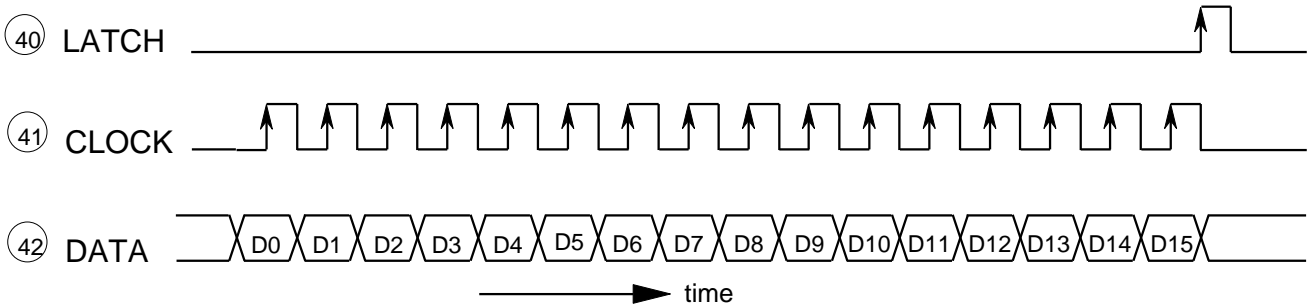

DATA	FUNCTION	Control description	DATA	FUNCTION	Control description
D0 "L"	D1	Digital echo Creates four kinds of delay signals between 104.0msec and 208.1msec.	D0	Echo effect Volume Sets volume attenuation in 8 steps between +3dB ~ -15dB and - .	
	D2		D1		
	D3		D2		
	D4	Source selector Desired audio source operation to each "karaoke" software can be selected by the Source selector. 5 kinds	D4	Echo Feed Back Volume Sets volume attenuation in 5 steps between -2dB ~ -7dB and - .	
	D5		D5		
	D6		D6		
	D7	Phase shifter surround Surround is formed with phase shifter to increase the ambience of sound even when karaoke is used.	D7	MIC1 Volume Sets volume attenuation in 8 steps between 0dB ~ -18dB and - .	
	D8		D8		
	D9	Auto vocal support ON / OFF If you are in discomfort from unknown song, the vocal of the singer can be output support you. Selector switch for turning on/off of auto vocal support.	D9	MIC2 Volume Sets volume attenuation in 8 steps between 0dB ~ -18dB and - .	
	D10	KEYCON pass/through External keycontrol IC changeover corresponding or decorresponding to changeover switch.	D10		
	D11	MIC SW ON / OFF Selector switch for turning on/off of microphone signal mixing.	D11		
	D12,D13		TEST mode	D12	
D14	ADDRESS Data is taken inside D14=[L],D15=[H],and others cancel.		D13		
D15			D14	ADDRESS Data is taken inside D14=[L],D15=[H],and others cancel.	
			D15		

PRELIMINARY
 Notice : This is not a final specification.
 some parametric limits are subject to change.

M65856SP

DIGITAL ECHO WITH MICROPHONE MIXING CIRCUIT

FUNCTION CONTROL

• DELAY TIME CONTROL

Control Data				Delay time
D0	D3	D2	D1	
L	L	L	-	104.0msec
	L	H	-	138.7msec
	H	L	-	156.0msec
	H	H	L	208.1msec
	H	H	H	Delay off mode

• SOURCE SELECTOR

Control Data				Source select
D0	D6	D5	D4	
L	L	L	L	Lch, monaural
	L	L	H	Rch, monaural
	L	H	-	(L+R) / 2
	H	L	-	Vocal cut
	H	H	-	Stereo

• PHASE SHIFTER SURROUND CONTROL

Control Data			PHASE SHIFTER SURROUND	
D0	D8	D7	Surround SW	Effect
L	L	L	OFF	—
	L	H	ON	LOW
	H	L		MID
	H	H		HIGH

• AUTO VOCAL SUPPORT SWITCH

Control Data		Auto vocal support SW
D0	D9	
L	L	OFF
	H	ON

• Keycontrol IC pass / through SW

Control Data		Remark
D0	D10	
L	L	Correspond to external Keycontrol
	H	Uncorrespond to external Keycontrol

(Notice)

• MICROPHONE MIXING SWITCH

Control Data		MIC SW	Remark
D0	D11		
L	L	OFF	Microphone mixing OFF
	H	ON	Microphone mixing ON

(Notice) Please set source selector except for "stereo" when this switch correspond to external keycontrol, because the output signal for external keycontrol (34pin:SOURCEOUT)is corresponding to only monaural signal. (This IC is not corresponding to external keycontrol,when source selector set up "stereo".)

PRELIMINARY
 Notice : This is not a final specification.
 some parametric limits are subject to change.

M65856SP

DIGITAL ECHO WITH MICROPHONE MIXING CIRCUIT

VOLUME CONTROL

• Echo effect volume attenuation

Control Data				Attenuation (dB)
D0	D3	D2	D1	
H	L	L	L	+3
	L	L	H	0
	L	H	L	-3
	L	H	H	-6
	H	L	L	-9
	H	L	H	-12
	H	H	L	-15
	H	H	H	-

• Echo FEEDBACK volume attenuation

Control Data				Attenuation (dB)
D0	D6	D5	D4	
H	L	L	L	-2
	L	L	H	-3
	L	H	L	-5
	L	H	H	-7
	H	L	L	-

• Microphone volume attenuation

Control Data					Attenuation (dB)
D0	D9	D8	D7	MIC1 Volume	
	D12	D11	D10	MIC2 Volume	
H	L	L	L		0
	L	L	H		-3
	L	H	L		-6
	L	H	H		-9
	H	L	L		-12
	H	L	H		-15
	H	H	L		-18
	H	H	H		-

• ADDRESS CONTROL

Control Data			ADDRESS
D0	D15	D14	
L,H	L	L	Data Cancel
	L	H	
	H	L	Data take inside
	H	H	Data Cancel

PRELIMINARY
 Notice : This is not a final specification.
 some parametric limits are subject to change.

M65856SP

DIGITAL ECHO WITH MICROPHONE MIXING CIRCUIT

FUNCTION DESCRIPTION

(1) AUTO RESET

Settings are reset automatically when the IC is powered up. The reset state is automatically canceled approximately 120msec after powering up ($V_{CC}=5V$ and the capacitor connected to pin C=47 μ F).

By auto reset, operation mode setting become as follows.

- Delay Time Control : 104.0msec
- Phase Shifter Surround Control : OFF
- KEYCON pass/through SW : ON
- Echo effect Volume : -
- Microphone Volume Attenuation : -9dB
- Source Selector : stereo
- Auto Vocal support Switch : OFF
- Microphone Mixing Switch : OFF
- Echo Feed back Volume : -

(2) AUTO MUTE FUNCTION

The IC carries out auto mute function at the time of powering up, delay time setting change, in order to suppress shock noise that the digital delay may produce.

- At power up

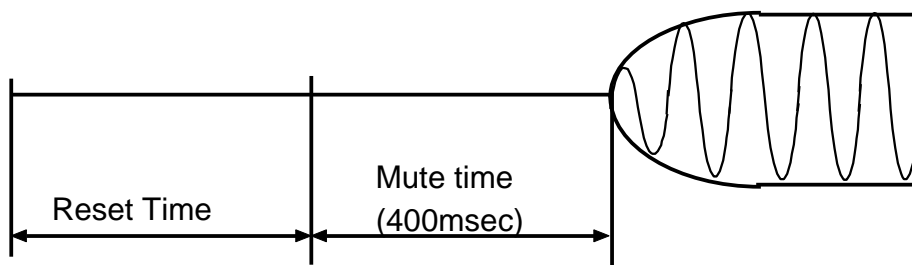

- At delay time setting change
- Delay signal before change

Delay signal after change

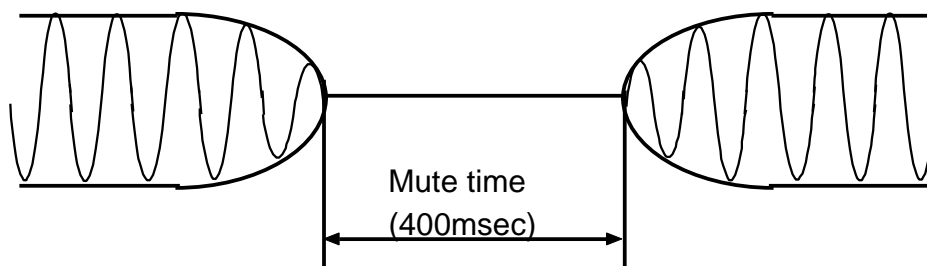

PRELIMINARY
 Notice : This is not a final specification.
 some parametric limits are subject to change.

M65856SP

DIGITAL ECHO WITH MICROPHONE MIXING CIRCUIT

(3) Clock oscillator circuit

This IC incorporates a current control type clock oscillator circuit in it, thus providing circuit configuration just by connecting an Rc for current control pin 2 (MCLKCONT). Fully internal clock supply prevents occurrence of undesired radiation without affecting any external circuit.

The oscillator frequency fck is following.

$$f_{ck} = 2 \text{ MHz}(R_c=56K \text{)}$$

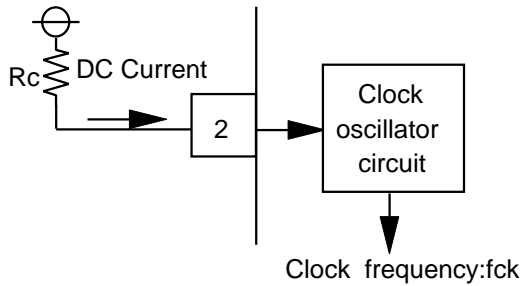

(4) Microphone amplifier

The gain(Gv) and low cut-off frequency(fcl) of microphone amplifier are expressed as follows.

$$G_v = 20 \log \left(\frac{R_1 + 1.5K + 334K}{R_1 + 1.5K} \right) \quad f_{cl} = \frac{1}{2 \cdot (R_1 + 1.5K) \cdot C_1}$$

$$G_v(\text{max}) = 47\text{dB}, f_{cl} = 48.2\text{Hz}$$

$$R_1 = 0, C_1 = 2.2\mu\text{F}$$

Assuming $G_v = 37\text{dB}$, $f_{cl} = 15.1\text{Hz}$, for instance, the constants take the following values.

$$R_1 = 3.3K, C_1 = 2.2\mu\text{F}$$

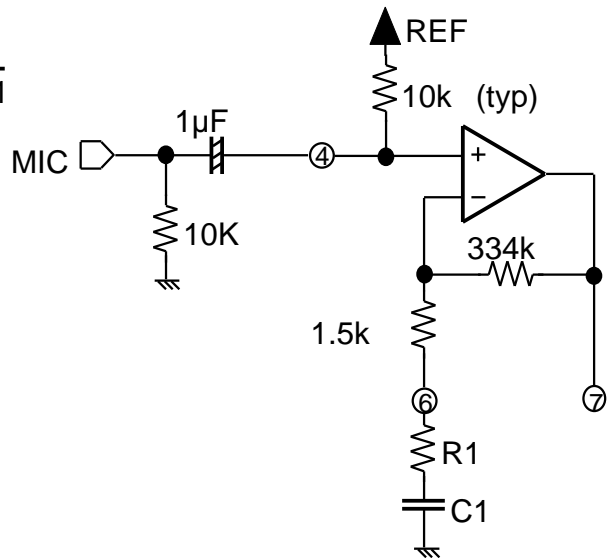

PRELIMINARY
 Notice: This is not a final specification.
 some parametric limits are subject to change.

M65856SP

DIGITAL ECHO WITH MICROPHONE MIXING CIRCUIT

(5) ALC level diagram

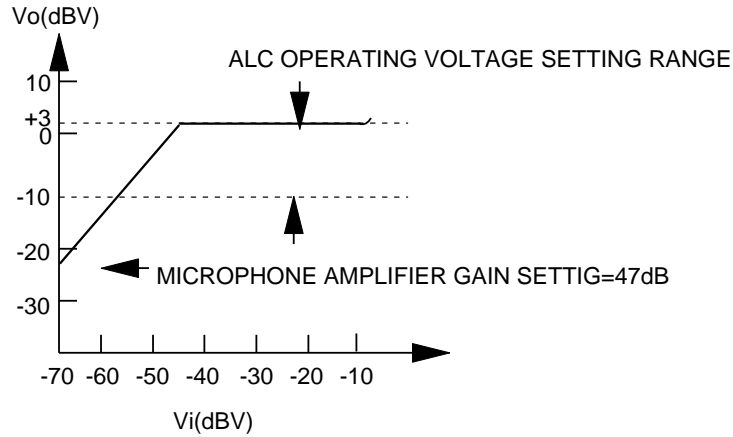

(6) ALC operating voltage setting

ALC operating voltage can be set at a desired value between -10dBV and +3dBV by varying the DC voltage applied to pin ③ (ALC operating voltage setting terminal).

(Setting method)

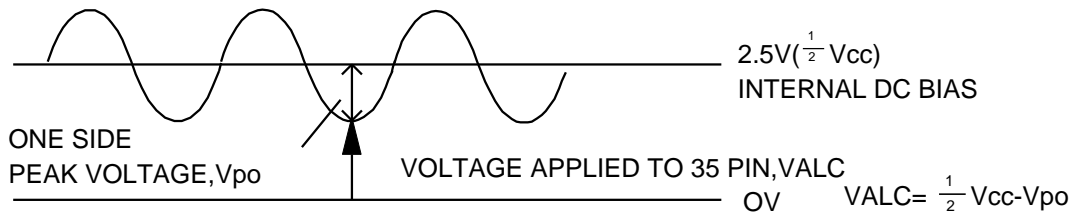

To set ALC operating voltage at -5dB ($V_{cc}=5V$)

$$-5dBV = 0.56V_{rms} = 1.59V_{p-p} = 0.8V_{p-o}$$

$$V_{ALC} = 2.5 - 0.8 = 1.7V$$

Since the input impedance at pin ⑤ ⑩ is high at 1M or more, it is possible to provide ALC operating voltage by dividing resistance.

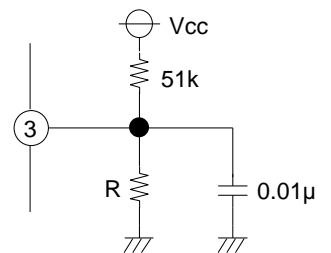

When $V_{cc}=5V$

ALC operating voltage (dBV)	Voltage applied to pin ⑤ ⑩ $V_{ALC}(V)$	Resistance R()
+3	0.50	5.6k
0	1.09	15k
-2	1.38	20k
-4	1.61	24k
-6	1.79	27k
-8	1.94	33k
-10	2.05	36k

PRELIMINARY
 Notice: This is not a final specification.
 some parametric limits are subject to change.

M65856SP

DIGITAL ECHO WITH MICROPHONE MIXING CIRCUIT

(7) Input and output LPF for the digital echo

The input and output LPF for the digital echo are configured as shown. figure below.

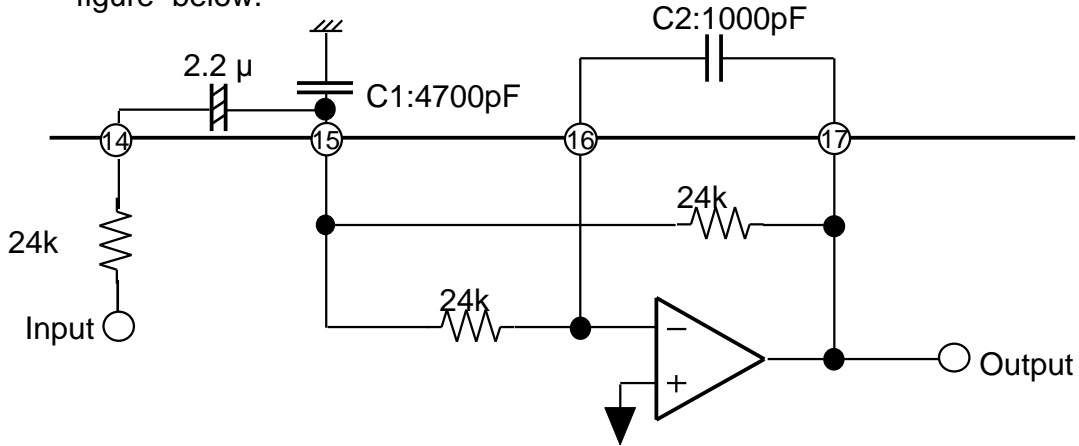

The accuracy of the internal resistance of the IC is approximately $\pm 30\%$

Cut-off frequency(f_c) is given as follows.

$$f_c = \frac{1}{2 \times 24k \times \sqrt{C1 \times C2}} = \frac{1}{2 \times 24k \times \sqrt{4700pF \times 1000pF}} \approx 3.1KHz$$

Quality factor (Q) is given by the following equation for long echo.

$$Q = \frac{1}{3N} \sqrt{\frac{C1}{C2}} \approx 0.72 \quad (\text{Figure of } 0.7 \text{ is recommended})$$

PRELIMINARY
 Notice : This is not a final specification.
 some parametric limits are subject to change.

M65856SP

DIGITAL ECHO WITH MICROPHONE MIXING CIRCUIT

(8) Auto vocal support

If you can not continue sing a song, the reference vocal from the source will support you automatically.

Signal Detection	Source selector mode		
	On	Lch monaural	vocal cut
Off	(L+R)/2	(L+R)/2	same as above

The timing of microphone input signal detection

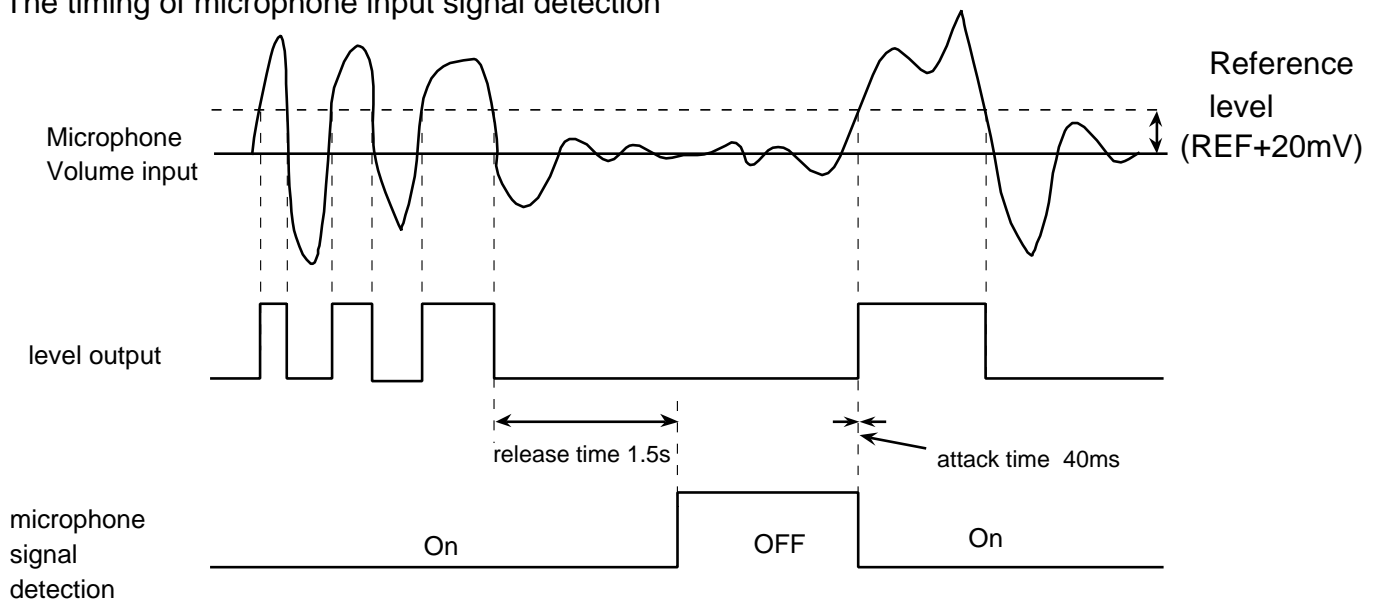

PRELIMINARY
 Notice : This is not a final specification.
 some parametric limits are subject to change.

M65856SP

DIGITAL ECHO WITH MICROPHONE MIXING CIRCUIT

(9) Vocal cut support

The sound components of the same phase and same sound volume in the L and R channels are attenuated.

This made also allows components with lower frequency than the vocal band to pass through the filter, to compensate insufficient low-frequency sound.

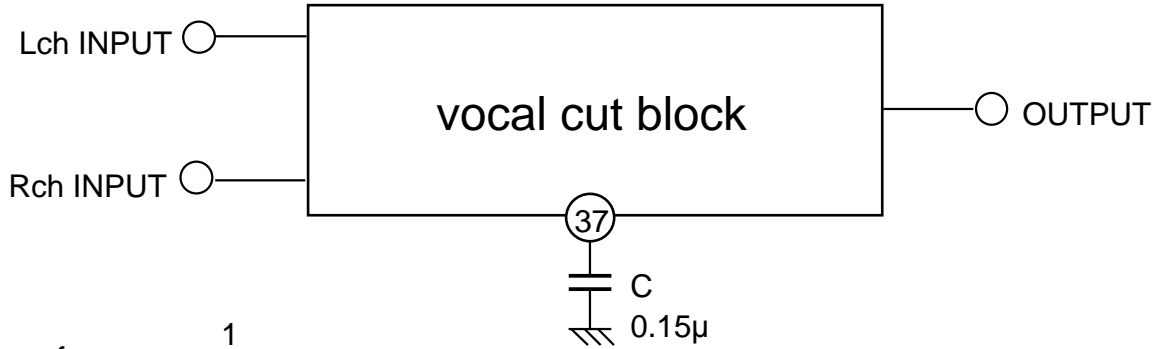

$$f_{vc} = \frac{1}{2 CR} = 53.0\text{Hz}$$

LPF is formed by the internal R (20k) and the external C, where C=0.15µF , cut off frequency is 53Hz.

(10) Following is the phase shifter block, which makes phase surround effect.

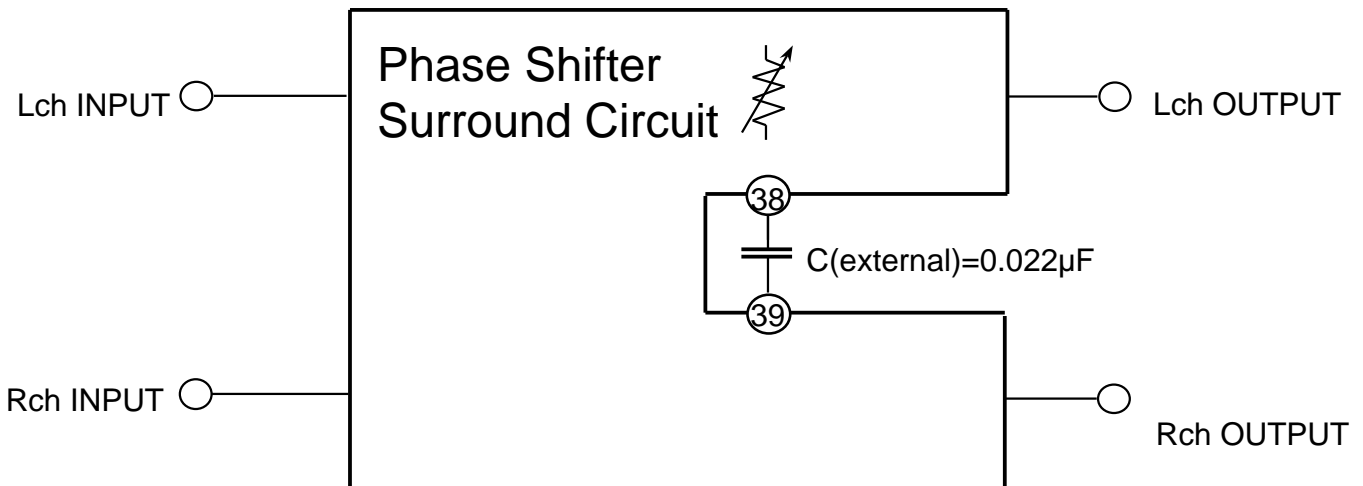

Source selector	Surround
L	Simulated Stereo
R	
(L+R)/2	
Vocal cut	
Stereo	Stereo Surround

PRELIMINARY
 Notice: This is not a final specification.
 some parametric limits are subject to change.

M65856SP

DIGITAL ECHO WITH MICROPHONE MIXING CIRCUIT

APPLICATION EXAMPLE

