

MA2Z077

Silicon epitaxial planar type

For band switching

■ Features

- Low forward dynamic resistance r_f
- Less voltage dependence of diode capacitance C_D
- S-mini type package, allowing downsizing of equipment and automatic insertion through the taping package

■ Absolute Maximum Ratings $T_a = 25^\circ\text{C}$

Parameter	Symbol	Rating	Unit
Reverse voltage (DC)	V_R	35	V
Forward current (DC)	I_F	100	mA
Operating ambient temperature*	T_{opr}	-25 to +85	$^\circ\text{C}$
Storage temperature	T_{stg}	-55 to +150	$^\circ\text{C}$

Note) * : Maximum ambient temperature during operation

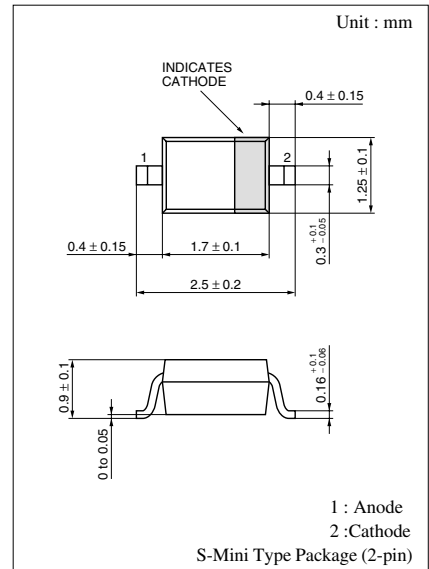

Marking Symbol: 4B

■ Electrical Characteristics $T_a = 25^\circ\text{C}$

Parameter	Symbol	Conditions	Min	Typ	Max	Unit
Reverse current (DC)	I_R	$V_R = 33 \text{ V}$		0.01	100	nA
Forward voltage (DC)	V_F	$I_F = 100 \text{ mA}$		0.92	1	V
Diode capacitance	C_D	$V_R = 6 \text{ V}, f = 1 \text{ MHz}$		0.9	1.2	pF
Forward dynamic resistance*	r_f	$I_F = 2 \text{ mA}, f = 100 \text{ MHz}$		0.65	0.85	Ω

Note) 1. Rated input/output frequency: 100 MHz

2. *: r_f measuring instrument: YHP MODEL 4191A RF IMPEDANCE ANALYZER

