

# Three-phase motor driver for CD-ROMs

## BA6858AFP / BA6858AFM / BA6859AFP / BA6859AFP-Y / BA6859AFM / BA6859AFS

The BA6858A and BA6859A series are ICs developed for CD-ROM spindle motor drives. In addition to the functions of the BA6849 series, (short brake, reverse-rotation prevention circuit, rotation direction detector, and FG output), the BA6858A and BA6859A series have a built-in brake mode switching pin. With torque command input, these series are compatible with the DSP3.3V. In addition, the BA6858A series has an FG composite output.

### ●Applications

CD-ROM, CD-R, CD-RW, DVD-ROM, and DVD-RAM

### ●Features

- 1) Three-phase, pseudo-linear drive system.
- 2) Built-in power save and thermal shutdown functions.
- 3) Built-in current limiter and Hall bias circuits.
- 4) Built-in FG output.
- 5) Built-in rotation direction detector.
- 6) Built-in reverse rotation prevention circuit.
- 7) Built-in short brake pin.
- 8) Built-in brake mode switching pin.
- 9) DSP3.3V compatible.

### ●Absolute maximum ratings (Ta = 25°C)

Parameter	Symbol	Limits	Unit	
Applied voltage (with 5V power supply)	V <sub>CC</sub>	7	V	
Applied voltage (motor power supply)	V <sub>M</sub>	15	V	
Power dissipation	BA6858AFM	2200* <sup>3</sup>	mW	
	BA6859AFM			
	BA6858AFP	Pd	1700* <sup>1</sup>	mW
	BA6859AFP			
	BA6859AFP-Y			
BA6859AFS	1450* <sup>2</sup>	mW		
		1000* <sup>4</sup>	mW	
Operating temperature	T <sub>opr</sub>	-20~+75	°C	
Storage temperature	T <sub>stg</sub>	-55~+150* <sup>5</sup>	°C	
Output current	I <sub>OUT</sub>	1300* <sup>6</sup>	mA	

\* When mounted on a 70mm × 70mm × 1.6mm glass epoxy board.

\*<sup>1</sup> Reduced by 13.6mW for each increase in Ta of 1°C over 25°C.

\*<sup>2</sup> Reduced by 11.6mW for each increase in Ta of 1°C over 25°C.

\*<sup>3</sup> Reduced by 17.6mW for each increase in Ta of 1°C over 25°C.

\*<sup>4</sup> Reduced by 8.0mW for each increase in Ta of 1°C over 25°C.

\*<sup>5</sup> T<sub>j</sub> should not exceed 150°C.

\*<sup>6</sup> Should not exceed Pd or ASO values.

● Recommended operating conditions (Ta = 25 °C)

Parameter	Symbol	Limits	Unit
Power supply voltage	V <sub>CC</sub>	4.5~5.5	V
	V <sub>M</sub>	3.0~14	V

● Block diagram

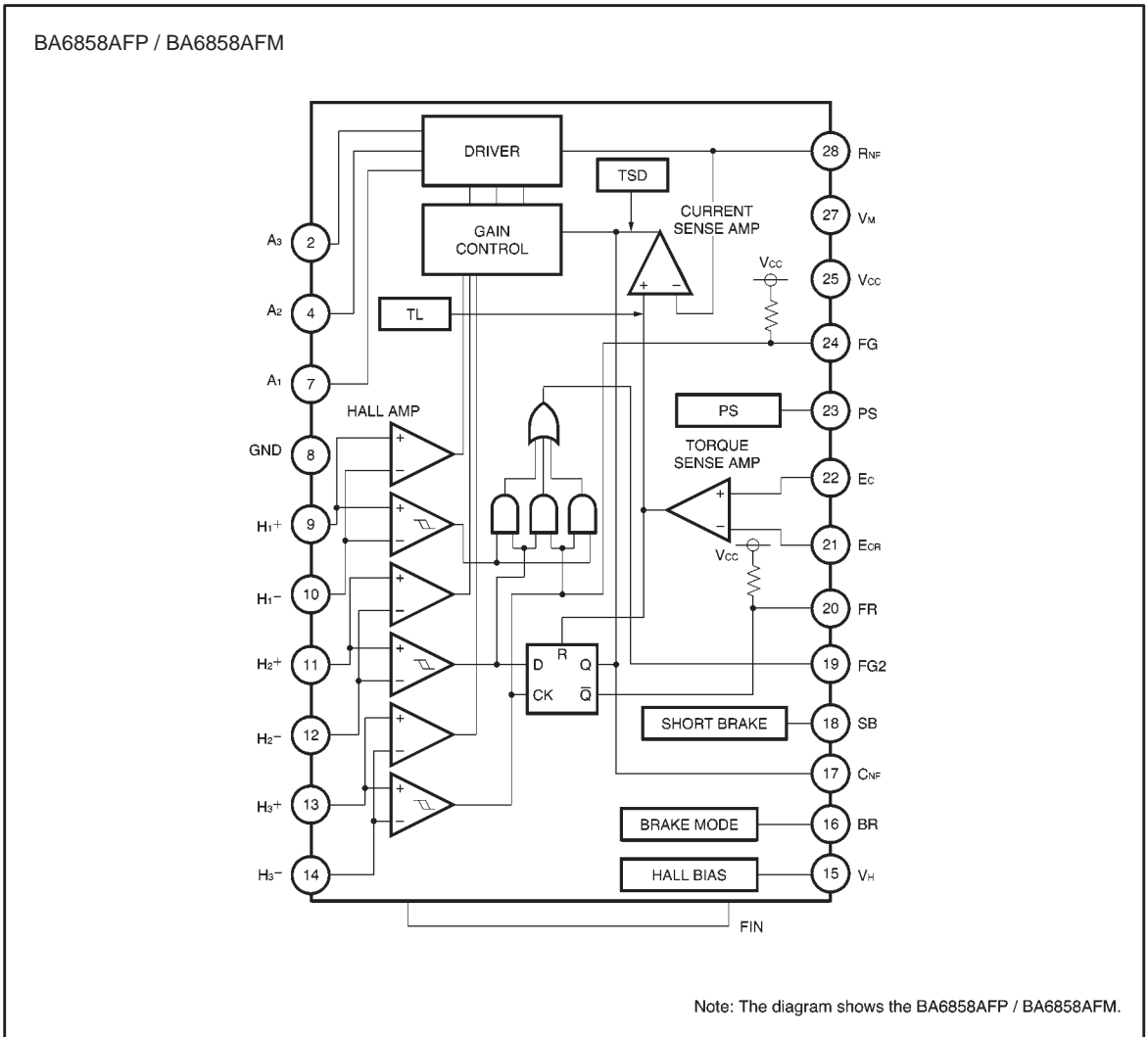

**Motor driver ICs**

## ● Pin descriptions

BA6858AFP/BA6858AFM

Pin No.	Pin name	Function
2	A <sub>3</sub>	Output
4	A <sub>2</sub>	Output
7	A <sub>1</sub>	Output
8	GND	GND
9	H <sub>1</sub> <sup>+</sup>	Hall signal input
10	H <sub>1</sub> <sup>-</sup>	Hall signal input
11	H <sub>2</sub> <sup>+</sup>	Hall signal input
12	H <sub>2</sub> <sup>-</sup>	Hall signal input
13	H <sub>3</sub> <sup>+</sup>	Hall signal input
14	H <sub>3</sub> <sup>-</sup>	Hall signal input
15	V <sub>H</sub>	Hall bias
16	BR	Brake mode switch
17	C <sub>NF</sub>	For connection of phase compensation capacitor
18	SB	Short brake
19	FG <sub>2</sub>	Three-phase composite FG signal output
20	FR	Rotation direction detection
21	E <sub>CR</sub>	Torque control reference
22	E <sub>C</sub>	Torque control
23	PS	Power save
24	FG	FG signal output
25	V <sub>CC</sub>	Power supply
27	V <sub>M</sub>	Motor power supply
28	R <sub>NF</sub>	For connection of output current detection resistor
FIN	—	SUB GND

\* Missing pin numbers are N.C.

BA6859AFP/BA6859AFM

Pin No.	Pin name	Function
2	A <sub>3</sub>	Output
4	A <sub>2</sub>	Output
7	A <sub>1</sub>	Output
8	GND	GND
9	H <sub>1</sub> <sup>+</sup>	Hall signal input
10	H <sub>1</sub> <sup>-</sup>	Hall signal input
11	H <sub>2</sub> <sup>+</sup>	Hall signal input
12	H <sub>2</sub> <sup>-</sup>	Hall signal input
13	H <sub>3</sub> <sup>+</sup>	Hall signal input
14	H <sub>3</sub> <sup>-</sup>	Hall signal input
15	V <sub>H</sub>	Hall bias
16	BR	Brake mode switch
17	C <sub>NF</sub>	For connection of phase compensation capacitor
18	SB	Short brake
20	FR	Rotation direction detection
21	E <sub>CR</sub>	Torque control reference
22	E <sub>c</sub>	Torque control
23	PS	Power save
24	FG	FG signal output
25	V <sub>CC</sub>	Power supply
27	V <sub>M</sub>	Motor power supply
28	R <sub>NF</sub>	For connection of output current detection resistor
FIN	—	SUB GND

\* Missing pin numbers are N.C.

BA6859AFP-Y

Pin No.	Pin name	Function
4	A <sub>3</sub>	Output
5	A <sub>2</sub>	Output
6	A <sub>1</sub>	Output
7	GND	GND
8	H <sub>1</sub> <sup>+</sup>	Hall signal input
9	H <sub>1</sub> <sup>-</sup>	Hall signal input
10	H <sub>2</sub> <sup>+</sup>	Hall signal input
11	H <sub>2</sub> <sup>-</sup>	Hall signal input
12	H <sub>3</sub> <sup>+</sup>	Hall signal input
13	H <sub>3</sub> <sup>-</sup>	Hall signal input
14	V <sub>H</sub>	Hall bias
15	BR	Brake mode switch
16	C <sub>NF</sub>	For connection of phase compensation capacitor
17	SB	Short brake
18	FR	Rotation direction detection
19	E <sub>CR</sub>	Torque control reference
20	E <sub>c</sub>	Torque control
21	PS	Power save
22	FG	FG signal output
23	V <sub>CC</sub>	Power supply
24	V <sub>M</sub>	Motor power supply
25	R <sub>NF</sub>	For connection of output current detection resistor
FIN	—	SUB GND

\* Missing pin numbers are N.C.

**Motor driver ICs**

## BA6859AFS

Pin No.	Pin name	Function
1	—	SUB GND
2	A <sub>3</sub>	Output
3	A <sub>2</sub>	Output
5	A <sub>1</sub>	Output
6	GND	GND
7	H <sub>1</sub> <sup>+</sup>	Hall signal input
8	H <sub>1</sub> <sup>-</sup>	Hall signal input
9	H <sub>2</sub> <sup>+</sup>	Hall signal input
10	H <sub>2</sub> <sup>-</sup>	Hall signal input
11	H <sub>3</sub> <sup>+</sup>	Hall signal input
12	H <sub>3</sub> <sup>-</sup>	Hall signal input
13	V <sub>H</sub>	Hall bias
14	BR	Brake mode switch
15	C <sub>NF</sub>	For connection of phase compensation capacitor
16	SB	Short brake
17	FR	Rotation direction detection
18	E <sub>CR</sub>	Torque control reference
19	E <sub>C</sub>	Torque control
20	PS	Power save
21	FG	FG signal output
22	V <sub>CC</sub>	Power supply
23	V <sub>M</sub>	Motor power supply
24	R <sub>NF</sub>	For connection of output current detection resistor

\* Missing pin numbers are N.C.

● Input / output circuits

(1) Power save

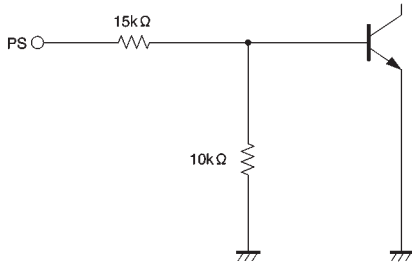

Fig.1

(2) Torque command input

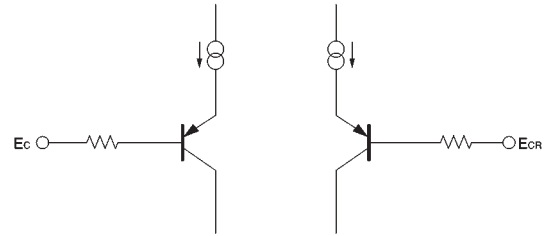

Fig.2

(3) Torque output ( $A_1$ ,  $A_2$ , and  $A_3$ )

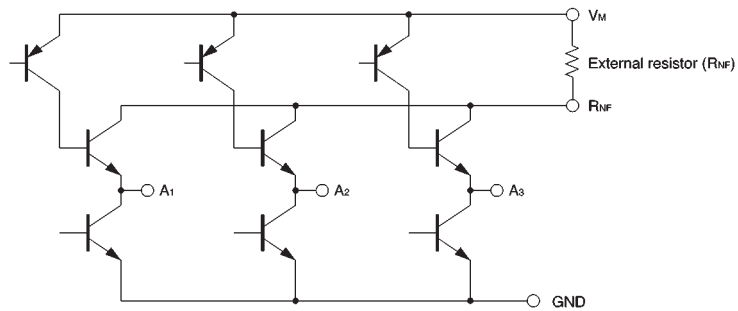

Fig.3

(4) Hall input ( $H_1^+$ ,  $H_1^-$ ,  $H_2^+$ ,  $H_2^-$ ,  $H_3^+$ ,  $H_3^-$ )

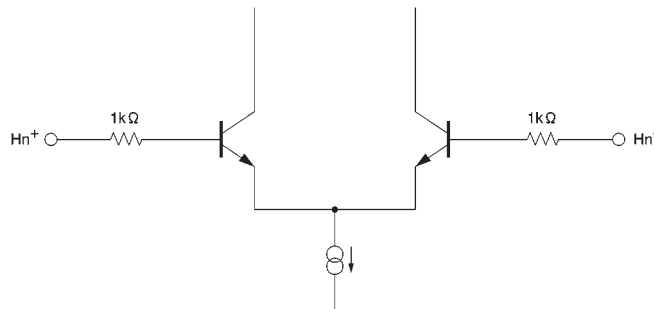

Fig.4

(5) Hall bias

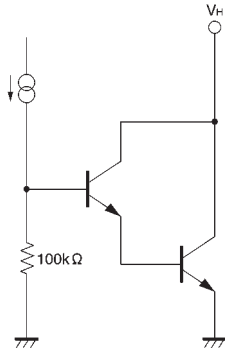

Fig.5

(7) FG<sub>2</sub> Output

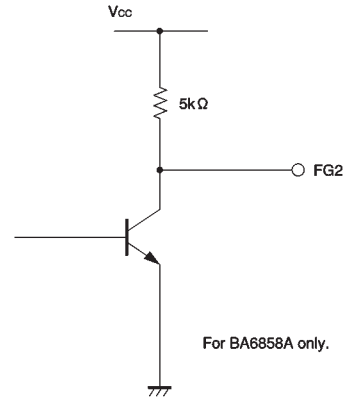

Fig.7

(6) FG output

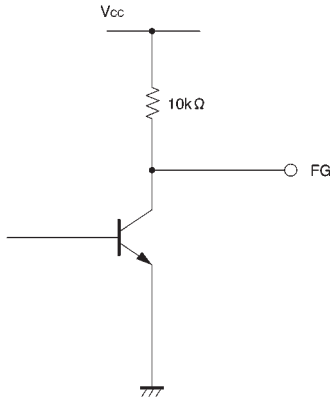

Fig.6

(8) FR output

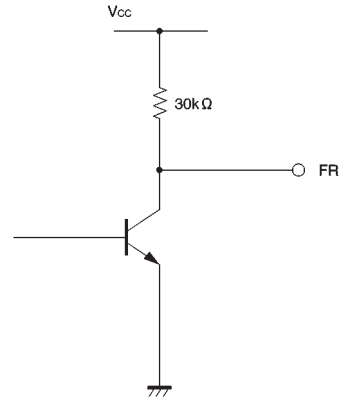

Fig.8

(9) Short brake

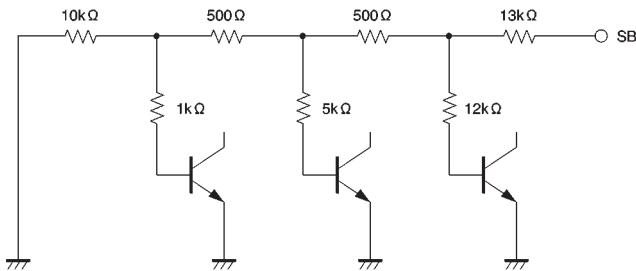

Fig.9

## Motor driver ICs

### (10) Brake mode

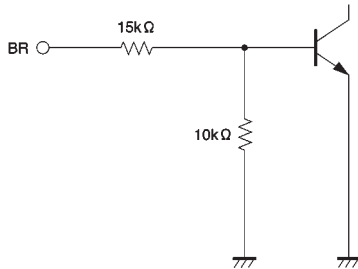

Fig.10

●Electrical characteristics (unless otherwise noted,  $T_a = 25^\circ\text{C}$ ,  $V_{CC} = 5\text{V}$ ,  $V_M = 12\text{V}$ )

Parameter	Symbol	Min.	Typ.	Max.	Unit	Conditions
〈Total device〉						
Circuit current 1	$I_{CC1}$	—	0	0.2	mA	In the power save ON state
Circuit current 2	$I_{CC2}$	—	5.8 5.0	8.5 (58A) 7.5 (59A)	mA	In the power save OFF state
〈Power save〉						
ON voltage range	$V_{PSON}$	—	—	1.0	V	—
OFF voltage range	$V_{PSOFF}$	2.5	—	—	V	—
〈Hall bias〉						
Hall bias voltage	$V_{HB}$	0.5	0.9	1.5	V	$I_{HB}=10\text{mA}$
〈Hall amplifier〉						
Input bias current	$I_{HA}$	—	0.7	3.0	$\mu\text{A}$	—
Same phase input voltage range	$V_{HAR}$	1.0	—	4.0	V	—
Minimum input level	$V_{INH}$	50	—	—	mV <sub>P-P</sub>	—
H3 hysteresis level	$V_{HYS}$	5	20	40	mV	—
〈Torque command〉						
Input voltage range	$E_C, E_{CR}$	0.5	—	3.3	V	Can operate from 0 to $V_{CC}$ .
"—" offset voltage	$E_{COFF^-}$	-80	-50	-20	mV	$E_{CR}=1.9\text{V}$
"+" offset voltage	$E_{COFF^+}$	20	50	80	mV	$E_{CR}=1.9\text{V}$
Input bias current	$E_{CIN}$	-3	—	3	$\mu\text{A}$	$E_C=E_{CR}$
I / O gain	$G_{EC}$	0.56	0.7	0.84	A / V	$E_C=1.2\text{V}, 1.7\text{V}$
〈FG〉						
FG output "H" voltage	$V_{FGH}$	4.5	4.8	—	V	$I_{FG}=-20\mu\text{A}$
FG output "L" voltage	$V_{FGL}$	—	0.25	0.4	V	$I_{FG}=3\text{mA}$
〈FG2〉 (BA6858A only)						
FG2 output high level voltage	$V_{FG2H}$	4.6	4.9	—	V	$I_{FG2}=-20\mu\text{A}$
FG2 output low level voltage	$V_{FG2L}$	—	0.25	0.4	V	$I_{FG2}=3\text{mA}$
DUTY (reference value)	DU	—	50	—	%	—

©Not designed for radiation resistance.



Parameter	Symbol	Min.	Typ.	Max.	Unit	Conditions
〈Rotation detection〉						
FR output high level voltage	V <sub>FRH</sub>	4.1	4.4	—	V	I <sub>FR</sub> =-20 μA
FR output low level voltage	V <sub>FRL</sub>	—	0.25	0.4	V	I <sub>FR</sub> =3mA
〈Output〉						
Output saturation high level voltage	V <sub>OH</sub>	—	1.0	1.4	V	I <sub>o</sub> =-600mA
Output saturation low level voltage	V <sub>OL</sub>	—	0.4	0.7	V	I <sub>o</sub> =600mA
Pre-drive current	I <sub>VML</sub>	—	35	70	mA	E <sub>c</sub> =0V output open
Output limit current	I <sub>TL</sub>	560	700	840	mA	—
〈Short brake〉						
ON voltage range	V <sub>SBON</sub>	2.5	—	—	V	BR=0V
OFF voltage range	V <sub>SBOFF</sub>	—	—	1.0	V	BR=0V
〈Brake mode〉						
ON voltage range	V <sub>BRON</sub>	2.5	—	—	V	E <sub>c</sub> > E <sub>CR</sub> SB open
OFF voltage range	V <sub>BROFF</sub>	—	—	1.0	V	E <sub>c</sub> > E <sub>CR</sub> SB open

©Not designed for radiation resistance.

● Circuit operation

(1) Hall input to coil output

The phase relationship between the Hall input signals and the output current and voltage is shown in Fig.11. The motor position data input via the Hall pins is amplified by the Hall amplifier, and formed into waveforms by the matrix block. These signals are input to the output driver that supplies the drive current to the motor coils.

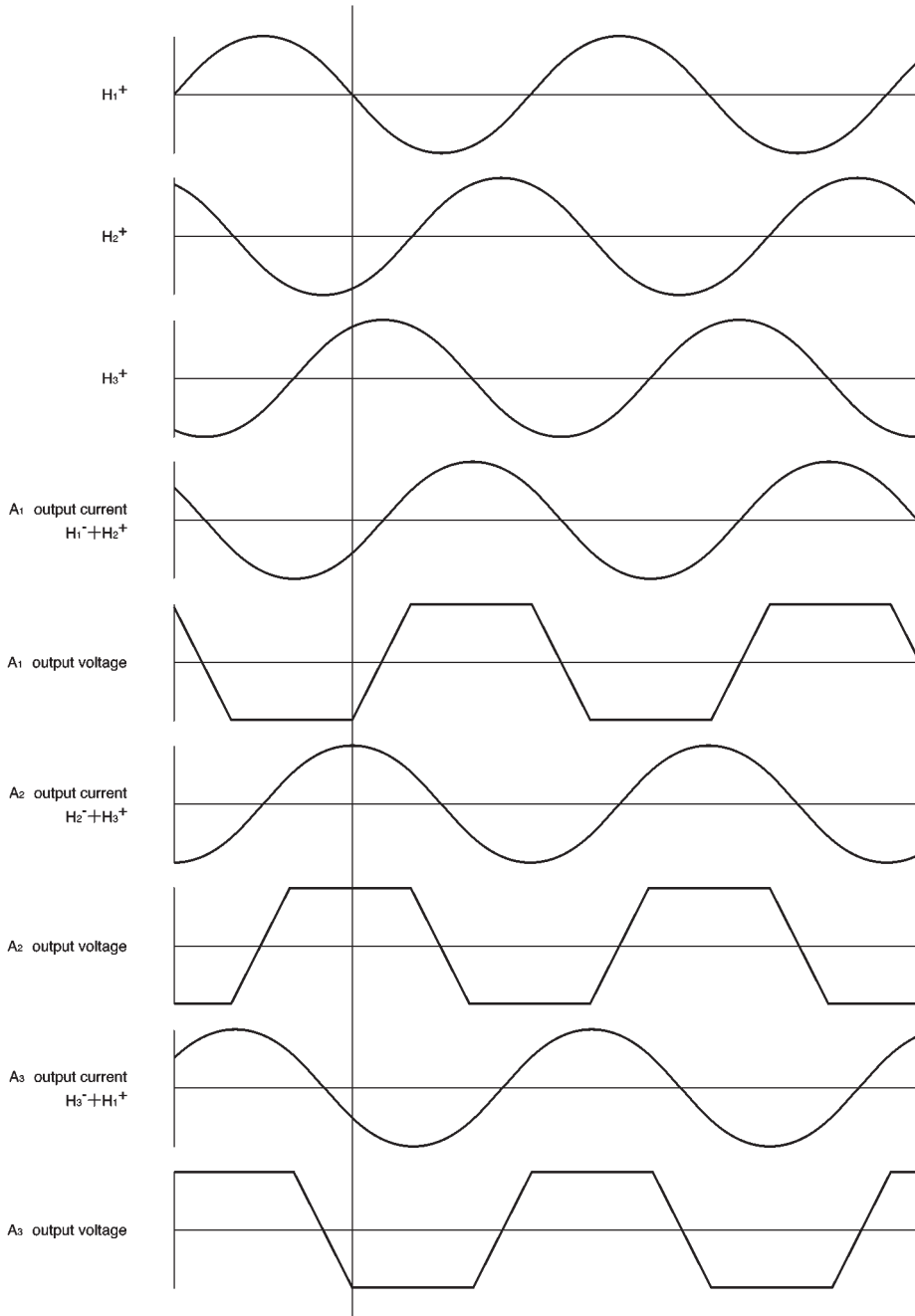

Fig.11

(2) Torque command

The  $R_{NF}$  pin voltage with respect to the torque command ( $E_c$ ) is as follows:

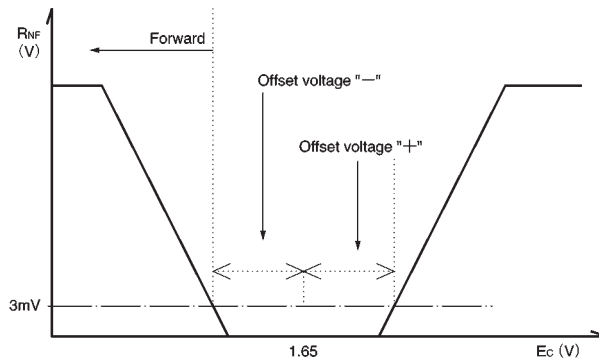

Fig.12

	Rotation direction
$E_c < E_{CR}$	Forward
$E_c > E_{CR}$	Reverse*

\* Stops after detecting reverse.

The I / O gain ( $G_{EC}$ ) from the  $E_c$  pin to the  $R_{NF}$  pin (output current) is determined by the  $R_{NF}$  detector resistor.

$$G_{EC} = 0.35 / R_{NF} \text{ (A / V)}$$

The torque limit current  $I_{TL}$  is given by:

$$I_{TL} = 0.35 / R_{NF} \text{ (A)}$$

(3) Reverse rotation detection function

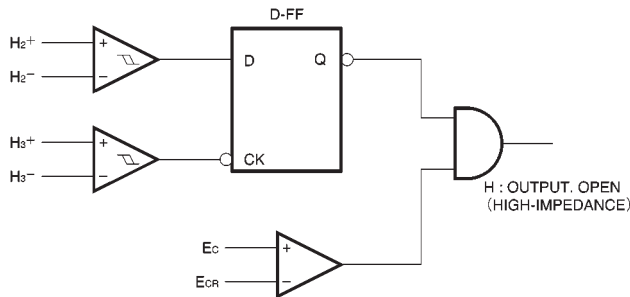

Fig.13

The reverse detection circuit construction is shown in Fig.13.

1) Forward ( $E_c < E_{CR}$ )

The phase relationship between the Hall input signals  $H_2^+$  and  $H_3^+$  becomes as shown in Fig.11, and the reverse rotation detection circuit does not operate.

2) Reverse ( $E_c > E_{CR}$ )

The phase relationship between the signals  $H_2^+$  and  $H_3^+$  is opposite that for forward operation, and the reverse rotation detection circuit operates. The output goes OFF, and becomes open circuit.

	FR signal output pin
Forward	L
Reverse	H

(4) Short brake

When 2.5V or more is applied to the short brake pin, the top-side output transistors of all phases go off, and the bottom-side output transistors go on. This applies braking to the motor. Short braking operates regardless of the torque command signal.

(5) Brake mode switching

When 2.5V or more is applied to the BR pin, the brake mode for when  $E_C > E_{CR}$  can be changed.

		$E_C < E_{CR}$	$E_C > E_{CR}$
BR	1.0 or less	Forward	Reverse brake
	2.5 or more	Forward	Short brake

(6) Power save

When 2.5V or more is applied to the power save pin, all circuits are on. When 1.0V or less is applied, the IC enters power save mode, and functions only for suppressing power consumption.

●Application example

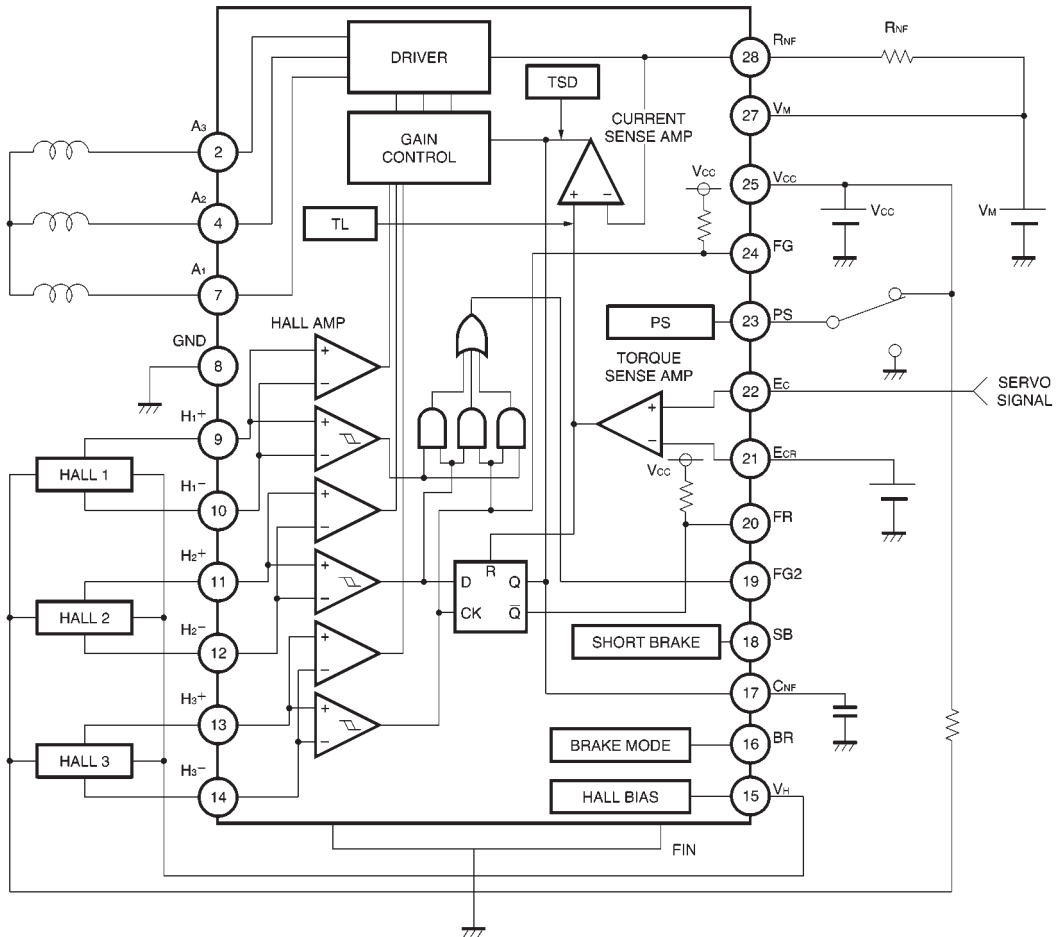

Fig.14

● Operation notes

(1) Torque command

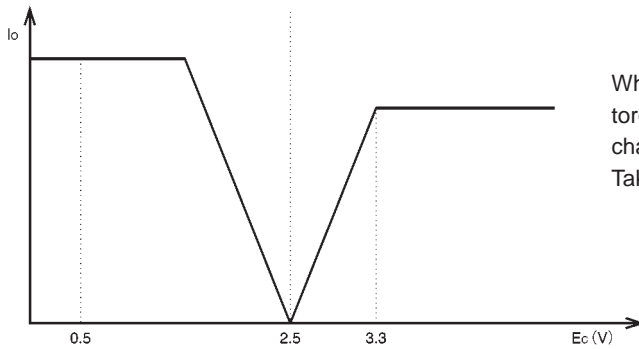

Fig.15

When operating with  $E_{CR} = 2.5$  V, the voltage range for the torque command input is 0.5 V to 3.3 V, and therefore, the characteristic will be unbalanced as shown in Fig.15. Take due care.

(2) Switches

The switches have a temperature characteristic of approximately  $-5$  mV / °C. Take care with regard to the input voltage range.

(3) Hall input

The input circuit shown in Fig.4 is used for the Hall inputs. The Hall elements can be connected either in series or in parallel.

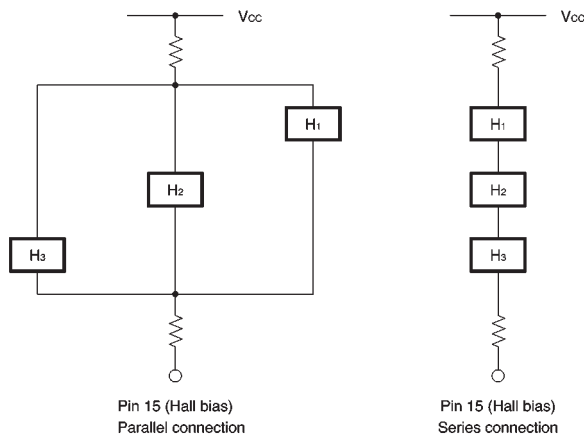

Fig.16

Set the Hall input voltage in the range 1.0 V to 4.0 V.

Set the resistance values between  $V_H$  and  $V_{CC}$  pins and the Hall elements after calculating the current to flow in Hall elements.

If there will not be a resistor connected between the Hall elements and the  $V_H$  pin, we recommend that  $I_{VH} = 5$  mA or more.

(4) Thermal shutdown (TSD)

When the junction temperature reaches 175°C (Typ.), the  $A_1$ ,  $A_2$ , and  $A_3$  coil outputs go open circuit.

The thermal shutdown has approximately 15°C (Typ.) of hysteresis.

● Electrical characteristics curves

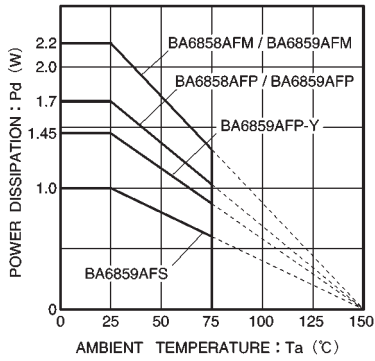

Fig.17 Package derating curves

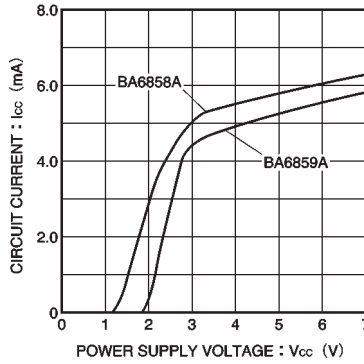

Fig.18 Power supply current vs. power supply voltage

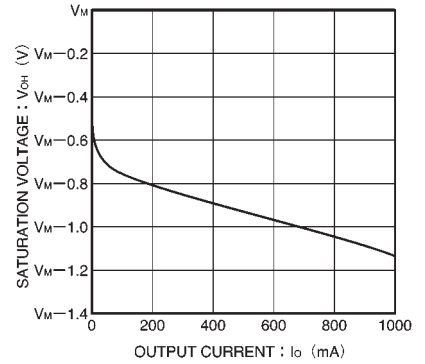

Fig.19 Upper-side output saturation voltage vs. output current

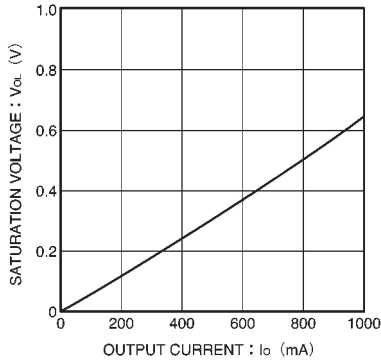

Fig.20 Lower-side output saturation voltage vs. output current

● External dimensions (Units: mm)

