

M51524L/P/FP

AUTO REVERSE PREAMPLIFIER WITH MUSIC SENSOR

DESCRIPTION

The M51524 is a preamplifier IC developed for car audio systems.

The IC, in addition to 2 channels of high-gain, low-noise preamplifiers, has a lead-in detection function suiting to auto reverse function and is capable of processing analog signals transmitted from the cassette deck.

Its applications cover home-use audio systems and portable radio CD/cassette players, as well as car audio systems.

FEATURES

- Built-in electronic switch for forward/reverse selection offers capability of switching 2 channels with a single switch.
- Built-in switch for forward/reverse switching makes it possible to switch 2 channels with a single switch.
- Use of reference voltage of bias circuit eliminates the need for input coupling capacitor.
- 2 channels of high-gain, low-noise preamplifiers built-in.
- Internal direct connections between each preamplifier output and high-gain mixing amplifier, without using coupling capacitor.
- Built-in filter circuits for prevention of malfunctioning caused by tape pop up noise at music blank.
- Built-in reset circuit to reset music selection at power up.
- Capable of setting timing for music blank by means of external CR combination.



Outline 20P5A(L)
1.27mm pitch 325mil ZIP
(2.8mm × 25.2mm × 6.3mm)

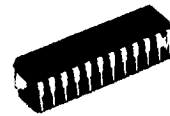

Outline 24P4D(P)
2.54mm pitch 300mil DIP
(6.3mm × 29.2mm × 3.3mm)



Outline 24P2N-B(FP)
1.27mm pitch 300mil SOP
(5.3mm × 15.02mm × 1.8mm)

RECOMMENDED OPERATING CONDITIONS

Supply voltage range.....Vcc = 6 to 15V
Rated supply voltage.....Vcc = 8V

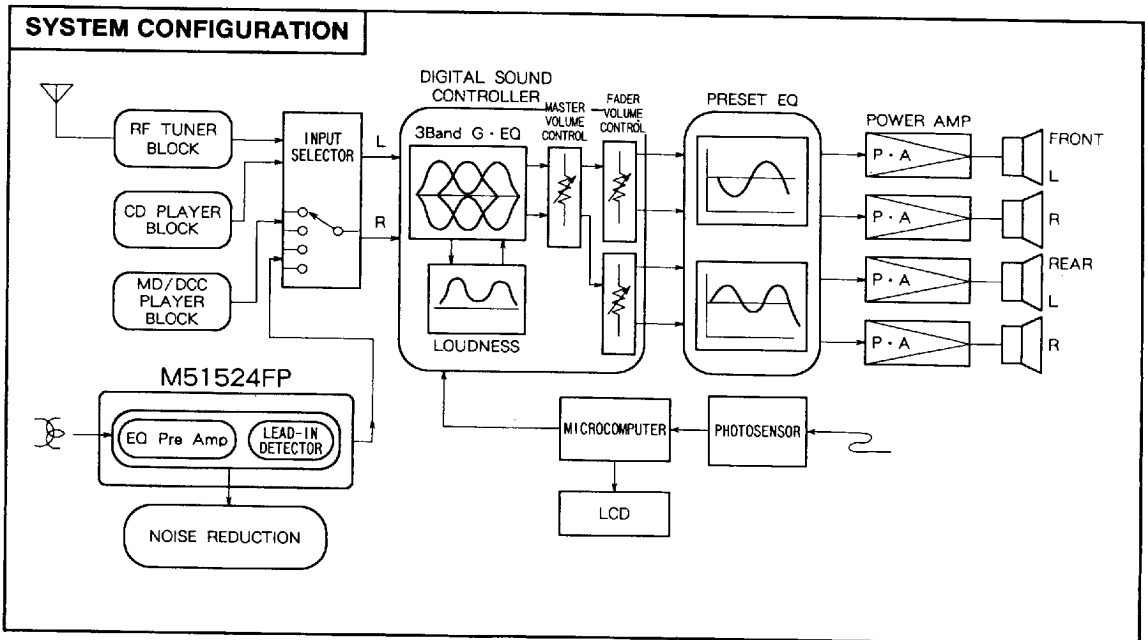

6249826 0022528 TT7



M51524L/P/FP

AUTO REVERSE PREAMPLIFIER WITH MUSIC SENSOR

PIN CONFIGURATION (TOP VIEW)

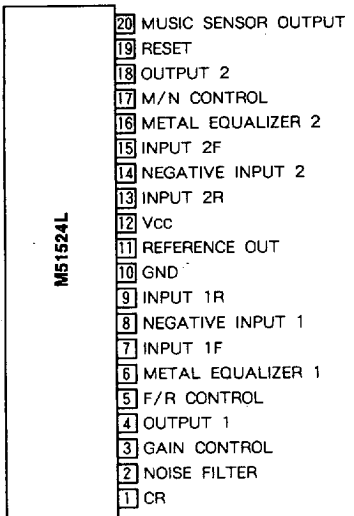

Outline 20P5A(L)

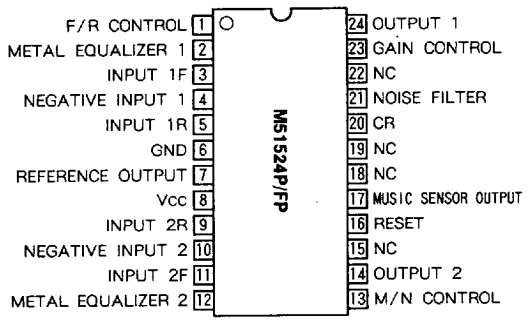

Outline 24P4D(P)
24P2N-B(FP)

NC : NO CONNECTION

6249826 0022529 933



AUTO REVERSE PREAMPLIFIER WITH MUSIC SENSOR

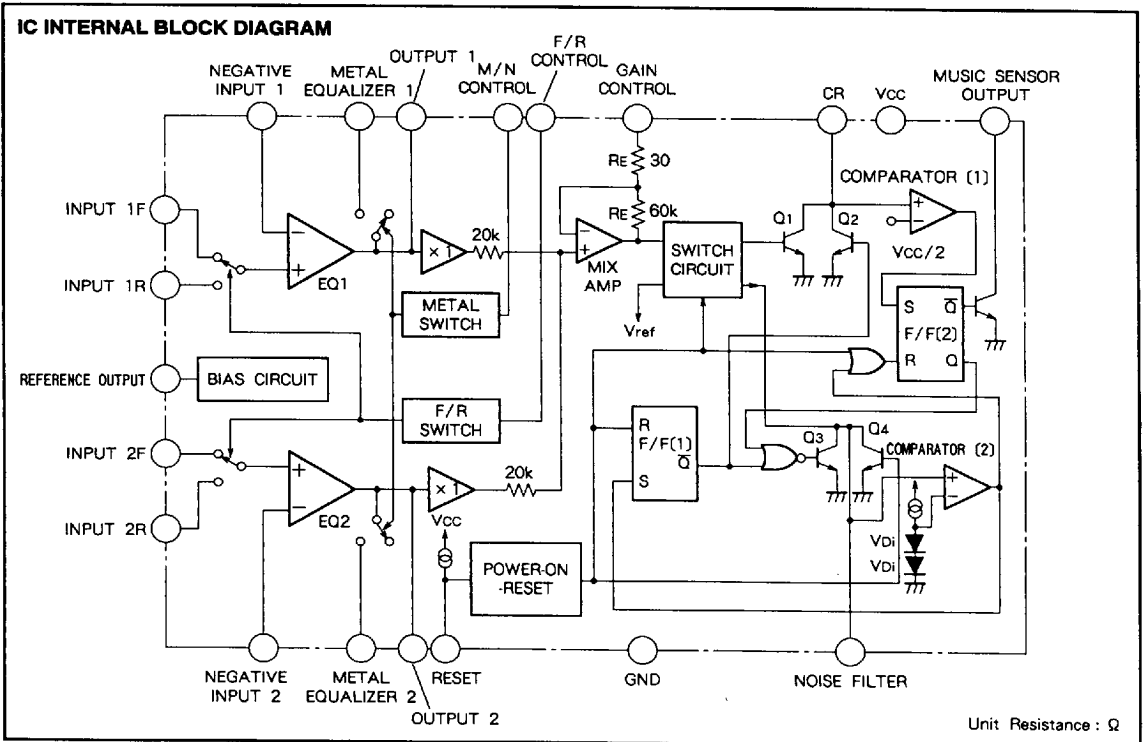

6249826 0022530 655



AUTO REVERSE PREAMPLIFIER WITH MUSIC SENSOR

ABSOLUTE MAXIMUM RATINGS (Ta = 25 °C, unless otherwise noted)

Symbol	Parameter	Conditions	Ratings	Unit
Vcc	Supply voltage		16	V
Icc	Circuit current		40	mA
Pd	Power dissipation	(M51524L)	800	mW
		(M51524P)	1000	
		(M51524FP)	500	
K θ	Thermal derating	(M51524L)	8	mW/°C
		(M51524P)	10	
		(M51524FP)	5	
T _{opr}	Operating temperature		- 20 to + 75	°C
T _{stg}	Storage temperature		- 40 to + 125	°C

ELECTRICAL CHARACTERISTICS (f = 1kHz, R_g = 620 Ω , V_{cc} = 8V, Normal equalizer, Ta = 25 °C, unless otherwise noted)

Symbol	Parameter	Test conditions	Limits			Unit
			Min	Typ	Max	
I _{cc}	Circuit current	Quiescent circuit current	-	9	14	mA
G _{vo}	Open loop gain	C _E = 220 μ F	68	80	-	dB
G _{vc}	Closed loop gain		38.5	40.5	42.5	dB
THD	Total harmonic distortion	V _o = 0.5V _{rms}	-	0.06	0.2	%
V _{omax}	Maximum output voltage	THD = 1 %	1.5	2.0	-	V _{rms}
N _o	Output noise voltage	BW = 20Hz to 20kHz	-	85	160	μ V _{rms}
S _{ep}	Separation	V _o = 0dBm, BW = 20Hz to 20kHz	45	63	-	dB
CT	Cross talk	V _o = 0dBm, BW = 20Hz to 20kHz	60	78	-	dB
I _{in1(20)}	CR circuit input current		-	- 0.1	- 0.6	μ A
V _{oL}	Music sensor output voltage Low		-	0.15	0.4	V
V _{th1(20)}	Comparator (1) threshold voltage		3.5	4.0	4.5	V
I ₁₉₍₁₆₎	Reset charging current		- 3	- 9	- 30	μ A
V ₁₉₍₁₆₎	Reset completion voltage		1.0	1.4	1.7	V
V _{th19(16)}	Reset threshold voltage		0.8	1.2	1.7	V
I ₂₍₂₁₎	Noise filter charging current		- 30	- 60	- 110	μ A
V _{th2(21)}	Comparator (2) threshold voltage		1.1	1.5	1.7	V
R _{s(1)}	Input impedance pin ⑤ (1)	V _{s(1)} = 1V	70	100	150	k Ω
R _{i7(13)}	Input impedance pin ⑩ (13)	V _{i7(13)} = 1V	70	100	150	k Ω

Note1. () M51524P,FP,AFP

6249826 0022531 591



AUTO REVERSE PREAMPLIFIER WITH MUSIC SENSOR

TYPICAL CHARACTERISTICS

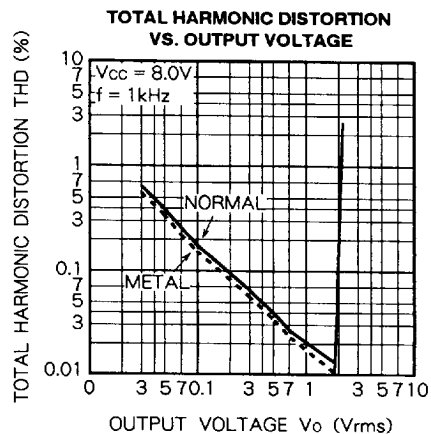
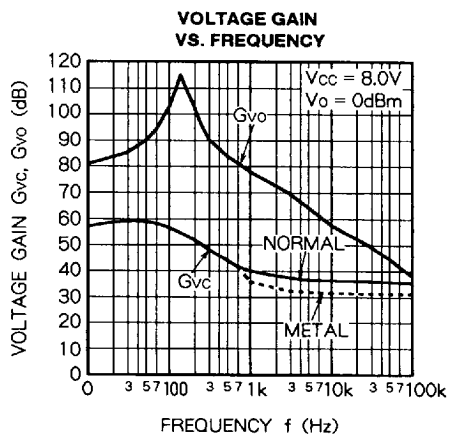
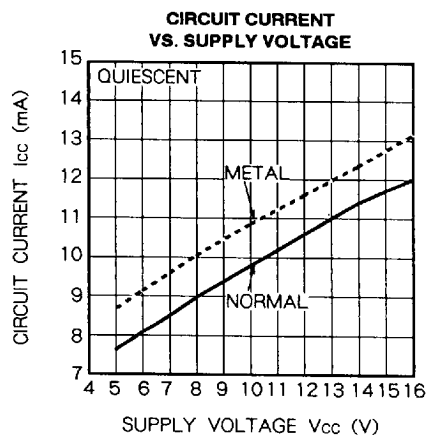
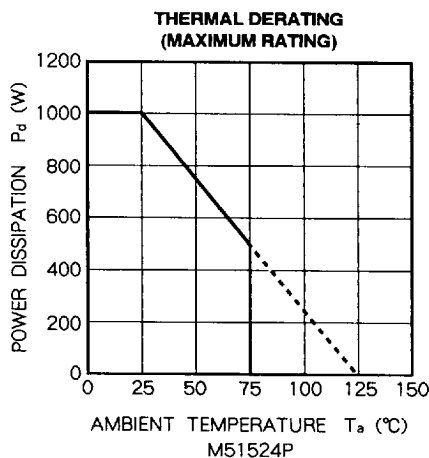
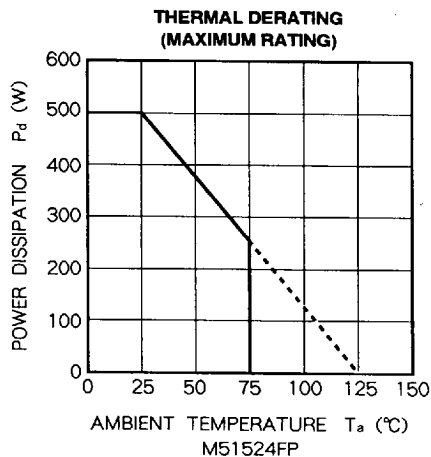
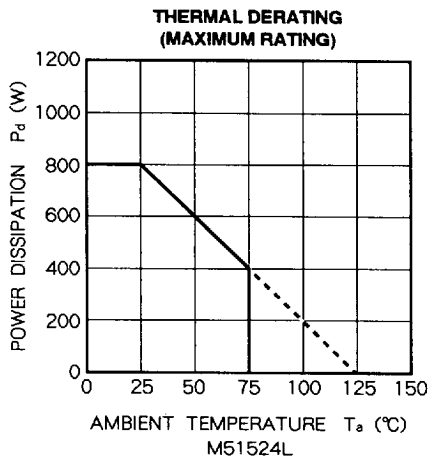

6249826 0022532 428



M51524L/P/FP

AUTO REVERSE PREAMPLIFIER WITH MUSIC SENSOR

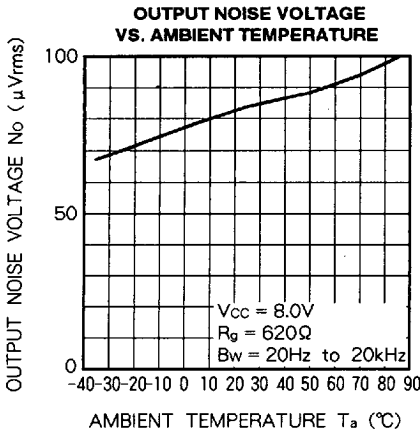
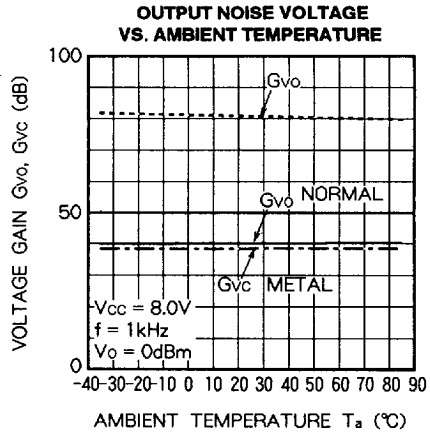
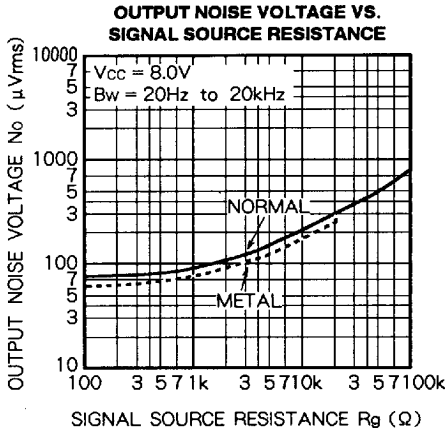

■ 6249826 0022533 364 ■



AUTO REVERSE PREAMPLIFIER WITH MUSIC SENSOR

TEST CIRCUIT (M51524P/FP)

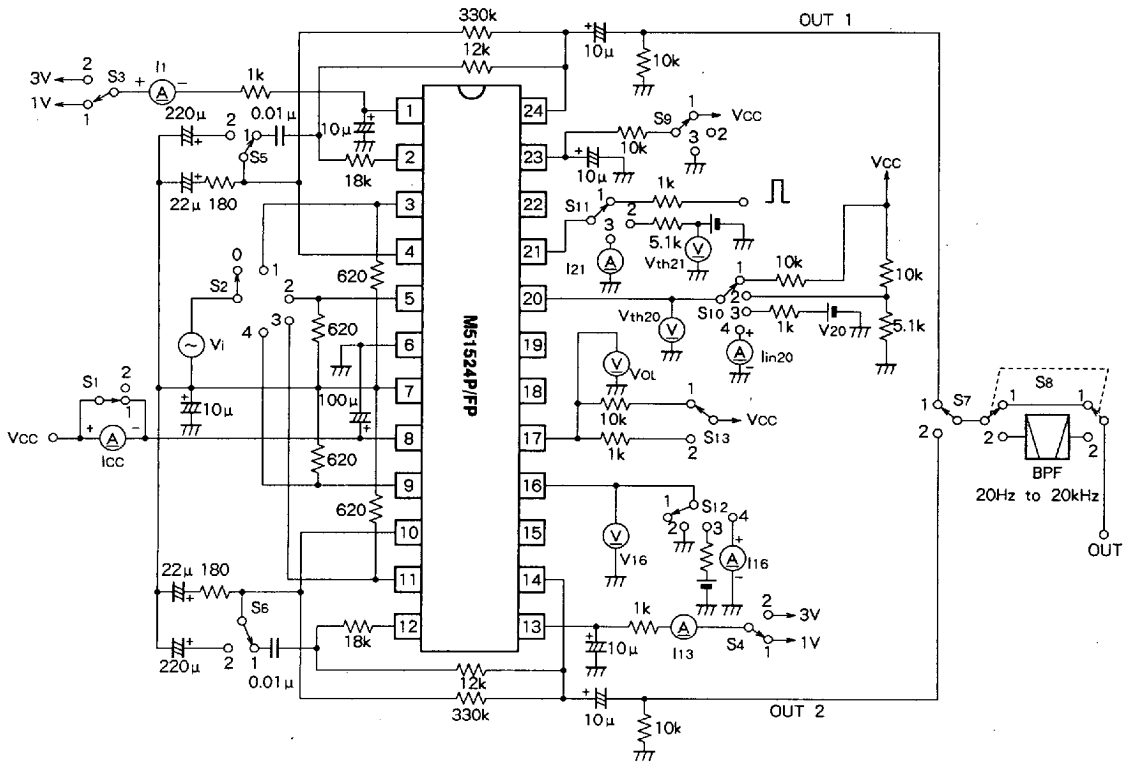

Units Resistance : Ω
Capacitance : F

6249826 0022535 137



AUTO REVERSE PREAMPLIFIER WITH MUSIC SENSOR

TEST CONDITIONS

Parameter	S1	S2	S3	S4	S5	S6	S7	S8	S9	S10	S11	S12	S13	Methods
I _{cc}	2	0	1	1	1	1	1	1	2	1	1	1	1	Read value on ammeter
G _{vo}	1	1/2 3/4	1/2	1	2/1 1/2	1/1 2/2	1/1 2/2	1	2	1	1	2	1	G _{vo} = 20 log (V _o /V _i)
G _{vc}	1	1/3	1	1	1	1	1/2	1	2	1	1	2	1	G _{vc} = 20 log (V _o /V _i)
THD	1	1/3	1	1	1	1	1/2	1	2	1	1	2	1	Read value on distortion meter at V _o = 0.5V _{rms}
V _{omax}	1	1/3	1	1	1	1	1/2	1	2	1	1	2	1	Measure output voltage at THD = 1%
N _o	1	0	1/2	1	1	1	1/2	2	2	1	1	2	1	BW = 20Hz to 20kHz
Sep	1	1/3	1	1	1	1	1,2 1,2	2	2	1	1	2	1	Measure output voltage when another output voltage is 0dBm. BW = 20Hz to 20kHz, Sep = V _o (dB)
CT	1	1/2 3/4	1,2 1,2	1	1	1	1/2	2	2	1	1	2	1	Measure crosstalk between Forward and Reverse V _i = 0dBm, BW = 20Hz to 20kHz
I _{in1} (20)	1	0	1	1	1	1	1	1	2	4	1	1	2	Measure current of pin①(20) after preset pulse enters to pin②(21)
V _{oL}	1	0	1	1	1	1	1	1	2	4	1	1	2	Measure voltage of pin②(17) after preset pulse enters to pin②(21)
V _{th1} (20)	1	0	1	1	1	1	1	1	2	3	1	1	1	Measure voltage of pin①(20) when V ₁ increases from 1V and output of pin②(17) changes to High from Low after preset pulse enters to pin②(21)
I ₁₉ (16)	1	0	1	1	1	1	1	1	2	1	1	4	1	Measure current with pin⑨(16)
V ₁₉ (16)	1	0	1	1	1	1	1	1	2	1	1	1	1	Measure voltage with pin⑨(16)
V _{th19} (16)	1	0	1	1	1	1	1	1	2	1	1	3	1	Measure voltage of pin⑨(16) when V ₁₉ decreases from 2V and output of pin②(17) changes to Low from High, after preset pulse enters to pin
I ₂ (21)	1	0	1	1	1	1	1	1	3	2	3	*	1	Measure current of pin②(21) after S ₁₂ changes to 1→2→1
V _{th2} (21)	1	0	1	1	1	1	1	1	2	2	2	*	1	Measure supply voltage of pin②(21) when V ₂ increases from 0.5V and voltage of pin①(20) changes to High (≈2.7V) from Low, after S ₁₂ changes to 1→2→1
R ₅ (1)	1	0	1	1	1	1	1	1	2	1	1	1	1	Measure current I _Ⓟ (1) at pin⑤(1) P _Ⓟ (1) = 1/I _Ⓟ (1)(kΩ)
R ₁₇ (13)	1	0	1	1	1	1	1	1	2	1	1	1	1	Measure current I _Ⓢ (13) at pin⑰(13) P _Ⓢ (13) = 1/I _Ⓢ (13)(kΩ)

Note 2. () M51524P, FP

6249826 0022536 073



