

## BiCMOS CURRENT MODE PWM CONTROLLERS

### FEATURES

- Low Power BiCMOS Design
- Tough CMOS™ Construction
- Low Supply Current ..... 1.0mA Typ @ 100kHz
- Wide Supply Voltage Operation ..... 8V to 15V
- Latch-Up Immunity ..... 500mA on Outputs
- Input Will Withstand Negative Inputs to - 5 Volts
- High Output Drive ..... 0.7A Peak  
(1.2A on 14-Pin and 16-Pin Versions)
- 2 kV ESD Protection
- Current Mode Control
- Fast Rise/Fall Time (Max) ..... 60nsec @ 1000pF
- High Frequency Operation ..... 500kHz
- Clock Ramp Reset Current ..... 2.5mA ±10%
- Low Propagation Delay Current Amp to Output ..... 140nsec Typ.
- Pin Compatible with UC3843

### ORDERING INFORMATION

| Part No.   | Package            | Temperature      |
|------------|--------------------|------------------|
| TC18C43MJA | 8-Pin CerDIP       | - 55°C to +125°C |
| TC18C43MJD | 14-Pin CerDIP      | - 55°C to +125°C |
| TC28C43EOE | 16-Pin SOIC (Wide) | - 40°C to +85°C  |
| TC28C43EPA | 8-Pin Plastic DIP  | - 40°C to +85°C  |
| TC28C43EPD | 14-Pin Plastic DIP | - 40°C to +85°C  |
| TC38C43COE | 16-Pin SOIC (Wide) | 0°C to +70°C     |
| TC38C43CPA | 8-Pin Plastic DIP  | 0°C to +70°C     |
| TC38C43CPD | 14-Pin Plastic DIP | 0°C to +70°C     |

### PIN CONFIGURATIONS

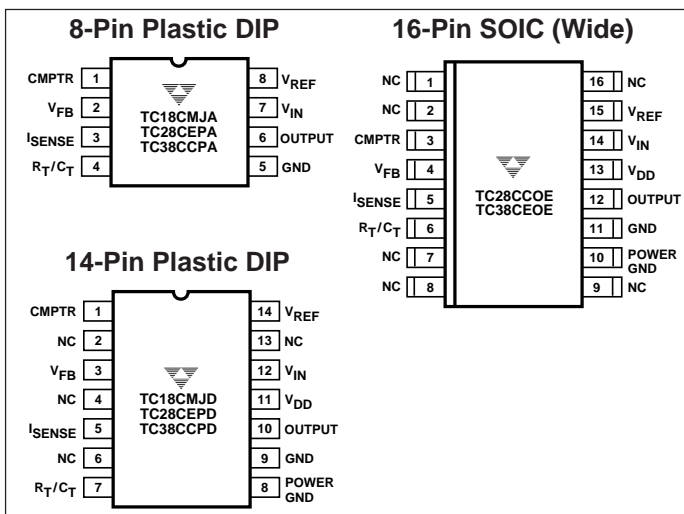

### GENERAL DESCRIPTION

The TC38C43 is a current mode BiCMOS PWM control IC. With a low 1.0 mA supply current along with high drive current (0.7A peak) it provides a low cost solution for a PWM that operates to 500 kHz and directly drives MOSFETs up to HEX 3 size.

Performance of the oscillator and current sense amplifier have been greatly improved over previous bipolar versions. Voltage and temperature stability have been improved by a factor of 3. Noise immunity (PSRR) has also been improved.

The TC38C43 is pin compatible with the earlier bipolar version so that designers can easily update older designs. Improvements have been added, though. For example, clock ramp reset current is specified at 2.5mA (±10%) for accurate dead time control. A few component values must be changed (R<sub>T</sub> & C<sub>T</sub>) to use the TC38C43 in existing bipolar designs.

The 14-pin DIP and 16-pin SOIC versions have separate and internally isolated grounds, and are rated for higher output current (1.2A). These separate grounds allow for 'bootstrap' operation of the PWM to further improve efficiency.

### FUNCTIONAL BLOCK DIAGRAM

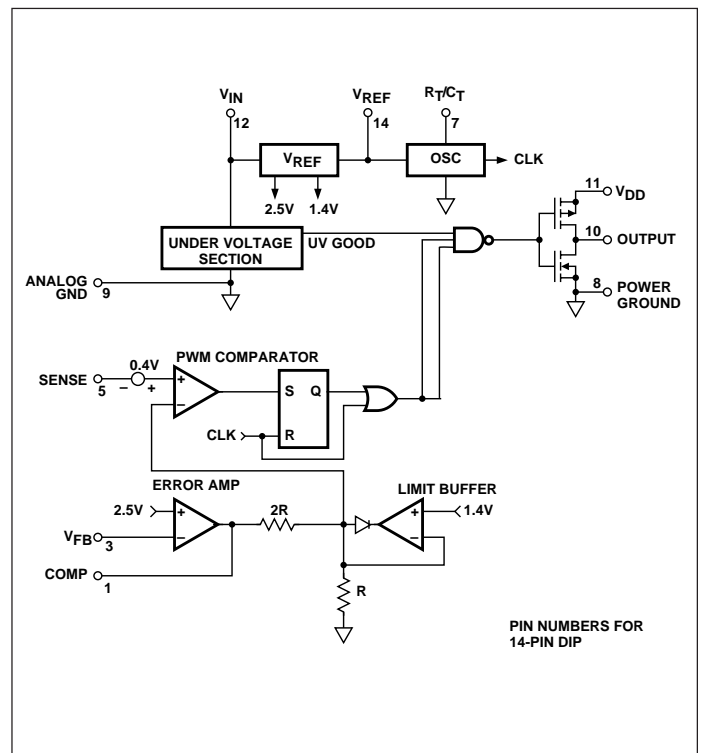

## TC18C43 TC28C43 TC38C43

### ABSOLUTE MAXIMUM RATINGS\*

|  |                 |
|--|-----------------|
| Supply Voltage .....                       | 18V             |
| Maximum Chip Temperature .....             | 150°C           |
| Storage Temperature .....                  | -65°C to +150°C |
| Lead Temperature (Soldering, 10 sec) ..... | +300°C          |
| Package Thermal Resistance                 |                 |
| CerDip R <sub>θJ-A</sub> .....             | 150°C/W         |
| CerDip R <sub>θJ-C</sub> .....             | 55°C/W          |

|                              |                                 |
|------------------------------|---------------------------------|
| PDIP R <sub>θJ-A</sub> ..... | 125°C/W                         |
| PDIP R <sub>θJ-C</sub> ..... | 45°C/W                          |
| SOIC R <sub>θJ-A</sub> ..... | 250°C/W                         |
| SOIC R <sub>θJ-C</sub> ..... | 75°C/W                          |
| Operating Temperature        |                                 |
| 18C4x .....                  | -55°C ≤ T <sub>A</sub> ≤ +125°C |
| 28C4x .....                  | -40°C ≤ T <sub>A</sub> ≤ +85°C  |
| 38C4x .....                  | 0°C ≤ T <sub>A</sub> ≤ +70°C    |

**ELECTRICAL CHARACTERISTICS** unless otherwise stated, these specifications apply over specific temperature range. V<sub>IN</sub> = V<sub>DD</sub> = 15V; R<sub>T</sub> = 71 kΩ; C<sub>T</sub> = 150 pF.

| Parameter                    | Test Conditions   | TC18C43<br>TC28C43 |       |       | TC38C43 |       |       | Units   |
|------------------------------|---|--------------------|-------|-------|---------|-------|-------|---------|
|                              |   | Min                | Typ   | Max   | Min     | Typ   | Max   |         |
| <b>Reference Section</b>     |   |                    |       |       |         |       |       |         |
| Output Voltage               | T <sub>A</sub> = 25°C, I <sub>O</sub> = 1mA                             | 4.9                | 5     | 5.1   | 4.90    | 5     | 5.10  | V       |
| Line Regulation              | 9.5V ≤ V <sub>IN</sub> ≤ 15V, I <sub>O</sub> = 1mA                      | —                  | ±3    | ±10   | —       | ±3    | ±10   | mV      |
| Load Regulation              | 1mA ≤ I <sub>O</sub> ≤ 11mA   | —                  | ±5    | ±15   | —       | ±3    | ±10   | mV      |
| Temp Stability               | (Note 1)  | —                  | ±0.25 | ±0.5  | —       | ±0.25 | ±0.5  | mV/°C   |
| Output Noise Voltage         | 10Hz ≤ f ≤ 10 kHz, T <sub>A</sub> = 25°C (Note 1)                       | —                  | 100   | —     | —       | 100   | —     | μV(rms) |
| Long Term Stability          | T <sub>A</sub> = 125°C, 1000 Hrs. (Note 1)                              | —                  | ±0.5  | —     | —       | ±0.5  | —     | %       |
| Output Short Circuit         |   | -20                | -50   | -100  | -30     | -50   | -100  | mA      |
| <b>Oscillator Section</b>    |   |                    |       |       |         |       |       |         |
| Initial Accuracy             | T <sub>A</sub> = 25°C (Note 4)  | 90                 | 100   | 110   | 93.8    | 100   | 106.5 | kHz     |
| Voltage Stability            | 9.5V ≤ V <sub>IN</sub> ≤ 15V  | —                  | ±0.2  | ±0.3  | —       | ±0.2  | ±0.3  | %       |
| Temp Stability               | T <sub>MIN</sub> ≤ T <sub>A</sub> ≤ T <sub>MAX</sub> (Note 1); Figure 2 | —                  | ±0.01 | ±0.05 | —       | ±0.01 | ±0.03 | %/°C    |
| Clock Ramp Reset             | R <sub>T</sub> /C <sub>T</sub> Pin at 4V                                | 2.25               | 2.5   | 2.75  | 2.25    | 2.5   | 2.75  | mA      |
| Amplitude                    | R <sub>T</sub> /C <sub>T</sub> Pin Peak to Peak                         | 2.45               | 2.65  | 2.85  | 2.45    | 2.65  | 2.85  | V       |
| Maximum Freq                 | Note 1  | 1                  | —     | —     | 1       | —     | —     | MHz     |
| <b>Error Amp Section</b>     |   |                    |       |       |         |       |       |         |
| Input Offset Voltage         | V <sub>(CMPTR)</sub> = 2.5V   | —                  | ±15   | ±50   | —       | ±15   | ±50   | mV      |
| Input Bias Current           | (Note 1)  | —                  | ±0.3  | ±2    | —       | ±0.3  | ±2    | nA      |
| A <sub>VOL</sub>             | 2V ≤ V <sub>O</sub> ≤ 4V  | 70                 | 90    | —     | 70      | 90    | —     | dB      |
| Gain Bandwidth Product       | (Note 1)  | 650                | 750   | —     | 650     | 750   | —     | kHz     |
| PSRR                         | 9.5V ≤ V <sub>IN</sub> ≤ 15V  | 80                 | 100   | —     | 80      | 100   | —     | dB      |
| Output Sink Current          | V <sub>FB</sub> = 2.7V, V <sub>(CMPTR)</sub> = 1.1V (Note 1)            | 1.2                | 1.5   | —     | 1.5     | 1.7   | —     | mA      |
| Output Source Current        | V <sub>FB</sub> = 2.3V, V <sub>(CMPTR)</sub> = 5V (Note 1)              | 3                  | 3.4   | —     | 3.9     | 4.2   | —     | mA      |
| V <sub>OUT</sub> High        | V <sub>FB</sub> = 2.3V, R <sub>L</sub> = 10k to Ground                  | 5.65               | 6     | 6.5   | 5.65    | 6     | 6.5   | V       |
| V <sub>OUT</sub> Low         | V <sub>FB</sub> = 2.7V, R <sub>L</sub> = 10k to V <sub>REF</sub>        | 0.1                | 0.7   | 1.1   | 0.1     | 0.7   | 1.1   | V       |
| Rise Response                | Note 1  | —                  | 5     | 7     | —       | 5     | 7     | μsec    |
| Fall Response                | Note 1  | —                  | 3     | 5     | —       | 3     | 5     | μsec    |
| <b>Current Sense Section</b> |   |                    |       |       |         |       |       |         |
| Gain Ratio                   | Notes 2 & 3   | 2.8                | 2.9   | 3.1   | 2.8     | 2.9   | 3.1   | V/V     |
| Maximum Input Signal         | V <sub>(CMPTR)</sub> = 5V (Note 2)                                      | 0.85               | 0.95  | 1.05  | 0.85    | 0.95  | 1.05  | V       |
| PSRR                         | 9.5V ≤ V <sub>IN</sub> ≤ 15V (Notes 1, 2 & 5)                           | 70                 | 80    | —     | 70      | 80    | —     | dB      |
| Input Bias Current           | Note 1  | —                  | ±0.3  | ±2    | —       | ±0.3  | ±2    | nA      |
| Delay to Output              | V <sub>(ISENSE)</sub> = 1V (Note 1); Figure 3                           | —                  | 140   | 160   | —       | 140   | 150   | nsec    |

**ELECTRICAL CHARACTERISTICS (Cont):** unless otherwise stated, these specifications apply over specified temperature range.  $V_{IN} = V_{DD} = 15V$ ;  $R_T = 71\text{ k}\Omega$ ;  $C_T = 150\text{ pF}$ .

| Parameter                           | Test Conditions                                   | TC18C4X<br>TC28C4X |     |     | TC38C4X |     |     | Units    |
|-------------------------------------|---|--------------------|-----|-----|---------|-----|-----|----------|
|                                     |   | Min                | Typ | Max | Min     | Typ | Max |          |
| <b>Output Section</b>               |   |                    |     |     |         |     |     |          |
| $R_{DS} (ON)$                       | $I_{SINK} = 20mA$                                 | —                  | 7   | 15  | —       | 7   | 15  | $\Omega$ |
| $R_{DS} (ON)$                       | $I_{SOURCE} = 20mA$                               | —                  | 11  | 20  | —       | 11  | 15  | $\Omega$ |
| Rise Time                           | $C_L = 1nF$ (Note 1)                              | —                  | 40  | 60  | —       | 35  | 60  | nsec     |
| Fall Time                           | $C_L = 1nF$ (Note 1)                              | —                  | 30  | 60  | —       | 30  | 40  | nsec     |
| Cross Conduction                    | In Coulombs (Note 1)                              | —                  | 6.5 | —   | —       | 6.5 | —   | nC       |
| $V_{DD}$ Ma                         | Note 1  | —                  | —   | 18  | —       | —   | 18  | V        |
| <b>Undervoltage Lockout Section</b> |   |                    |     |     |         |     |     |          |
| Start Threshold                     | x8C43   | 7.9                | 8.4 | 8.8 | 7.9     | 8.4 | 8.8 | V        |
| Undervoltage Threshold              | x8C43   | 7.2                | 7.6 | 7.9 | 7.2     | 7.6 | 7.9 | V        |
| <b>PWM Section</b>                  |   |                    |     |     |         |     |     |          |
| Maximum Duty Cycle                  | x8C43 (Note 1)                                    | 95                 | 97  | 100 | 95      | 97  | 100 | %        |
| Minimum Duty Cycle                  |   |                    |     | 0   |         |     | 0   | %        |
| <b>Supply Current</b>               |   |                    |     |     |         |     |     |          |
| Start Up                            | $T_A = 25^\circ C$ , $V_{IN} < V_{UV}$ ; Figure 1 | 50                 | 170 | 300 | 50      | 170 | 300 | $\mu A$  |
| Operating                           | $V_{FB} = V(I_{SENSE}) = 0V$ ; Figure 4           |                    | 1   | 2   |         | 1   | 1.5 | mA       |

- NOTES:**
1. These parameters, although guaranteed over the recommended operating conditions, are not tested in production.
  2. Parameter measured at trip point of latch.
  3. Gain ratio is defined as:

$$\frac{\Delta V_{COMP}}{\Delta V(I_{SENSE})}$$

where  $0 \leq V(I_{SENSE}) \leq 0.8V$

4. Output frequency equals oscillator frequency for the x8C43.
5. PSRR of  $V_{REF}$ , Error Amp and PWM Comparator combination.

TelCom Semiconductor reserves the right to make changes in the circuitry or specifications detailed in this manual at any time without notice. Minimums and maximums are guaranteed. All other specifications are intended as guidelines only. TelCom Semiconductor assumes no responsibility for the use of any circuits described herein and makes no representations that they are free from patent infringement.

\*Static-sensitive device. Unused devices must be stored in conductive material. Protect devices from static discharge and static fields. Stresses above those listed under Absolute Maximum Ratings may cause permanent damage to the device. These are stress ratings only and functional operation of the device at these or any other conditions above those indicated in the operational sections of the specifications is not implied. Exposure to Absolute Maximum Rating Conditions for extended periods may affect device reliability.

## PIN DESCRIPTION

| Pin No.<br>8-Pin | Pin No<br>14-Pin | Pin No<br>16-Pin | Symbol      | Description  |
|------------------|------------------|------------------|-------------|--|
|                  | 2                | 1                | NC          | No Connection  |
|                  | 4                | 2                | NC          | No Connection  |
| 1                | 1                | 3                | COMPTR      | Compensation of the feedback loop response.  |
| 2                | 3                | 4                | $V_{FB}$    | Feedback of voltage to error amplifier to regulate voltage.  |
| 3                | 5                | 5                | $I_{SENSE}$ | For sensing pass transistor current and terminate drive when current limit threshold is reached at this pin.   |
| 4                | 7                | 6                | $R_T/C_T$   | Capacitor and resistor input to set oscillator frequency of this PWM controller. The resistor is connected from $V_{REF}$ output to $R_T/C_T$ . The capacitor is connected from $R_T/C_T$ to ANALOG GND. |

**TC18C43  
TC28C43  
TC38C43**

**PIN DESCRIPTION (Cont.)**

| Pin No.<br>8-Pin | Pin No<br>14-Pin | Pin No<br>16-Pin | Symbol           | Description  |
|------------------|------------------|------------------|------------------|--|
|                  | 6                | 7                | NC               | No Connection  |
|                  | 13               | 8                | NC               | No Connection  |
|                  |                  | 9                | NC               | No Connection  |
|                  | 8                | 10               | POWER GROUND     | Ground return of output driver.                              |
| 5                | 9                | 11               | ANALOG GND       | For all the low level analog signal returns.                 |
| 6                | 10               | 12               | OUTPUT           | Output to drive switching transistor gate input.             |
|                  | 11               | 13               | V <sub>DD</sub>  | Supply power input terminal for the output drivers.          |
| 7                | 12               | 14               | V <sub>IN</sub>  | Voltage bias supply of all PWM Controller circuit functions. |
| 8                | 14               | 15               | V <sub>REF</sub> | Reference: 5.0 volt output.                                  |
|                  |                  | 16               | NC               | No Connection.   |

**REFERENCE SECTION**

The reference is a zener-based design with a buffer amplifier to drive the output. It is unstable with capacitances between 0.01µF and 3.3µF. In a normal application a 4.7µF is used. In some lower noise layouts the capacitor can be eliminated entirely.

The reference is active as soon as the 38C4x has power supplied. This is different than its bipolar counterparts, in that the bipolar reference comes on only after the IC has come out of its under voltage mode. Thus, on the 38C4x, the reference pin can not be used as a reset function such as on a soft start circuit.

**OSCILLATOR SECTION**

The oscillator frequency is set by the combination of a resistor from the reference to the R<sub>T</sub>/C<sub>T</sub> pin and by a capacitor from this pin to ground. The oscillator is designed to have ramp amplitude from 0.15 to 2.5 volts. This is approximate, as over shoot on the oscillator comparator causes the ramp amplitude to increase with frequency due to comparator delay. Minimum values for C<sub>T</sub> and R<sub>T</sub> are 33pF and 1kΩ respectively. Maximum values are dependent on leakage currents in the capacitor, not on the input currents to the R<sub>T</sub>/C<sub>T</sub> pin.

**FREQUENCY OF OPERATION**

The frequency of oscillation for the TC38C43 is controlled by a resistor to V<sub>REF</sub> (R<sub>T</sub>) and a capacitor to ground (C<sub>T</sub>). V<sub>REF</sub> supplies current through the resistor and charges the capacitor until its voltage reaches the threshold of the upper comparator (≈2.5V). A 2.5mA current is then applied to the capacitor to discharge it to near ground (≈0.15V). The discharge current is then shut off and the cycle repeats. An approximate equation for the frequency of operation is:

$$f_o \approx \frac{1}{R_T C_T} \text{ (R}_T \text{ in Ohms and C}_T \text{ in Farads)}$$

The value of R<sub>T</sub> affects the discharge current and the upper and lower comparators each have delays. As R<sub>T</sub> gets smaller and as the frequency of operation gets higher, the above equation is no longer valid.

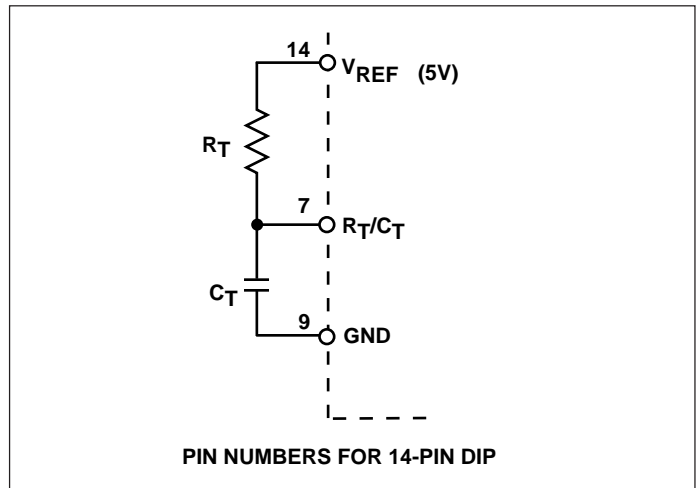

## Dead Time

The value of  $R_T$  has an effect on the discharge rate but the primary consideration is the value of  $C_T$ . The time required to discharge the capacitor is approximately  $1000 C_T$ .

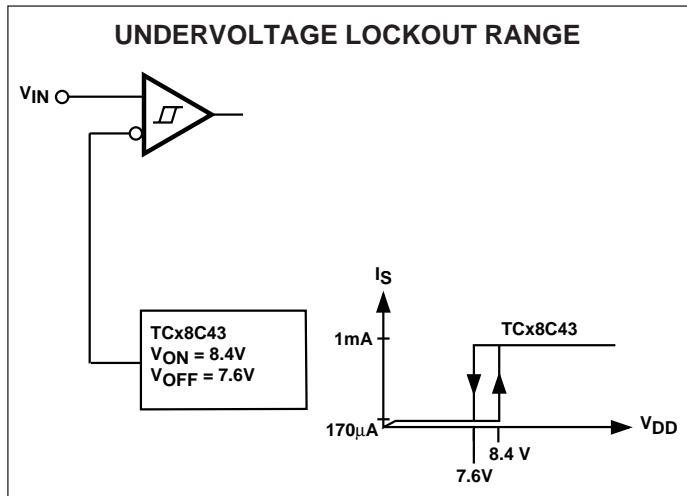

## Undervoltage Lockout Range

The TCx8C43 PWM Controller is used where wide ranges of input voltage is not required. The range from starting  $V_{in}$  voltage threshold to under voltage threshold is approximately 9.5% of the starting voltage. The typical start-up voltage is 8.4V and dropout voltage is 7.6V. This range is used most in DC-to-DC converter applications.

## Duty Cycle Limit

The TCx8C43 PWM Controller has a duty cycle limit maximum of 99%. The oscillator is running at the same frequency as the output.

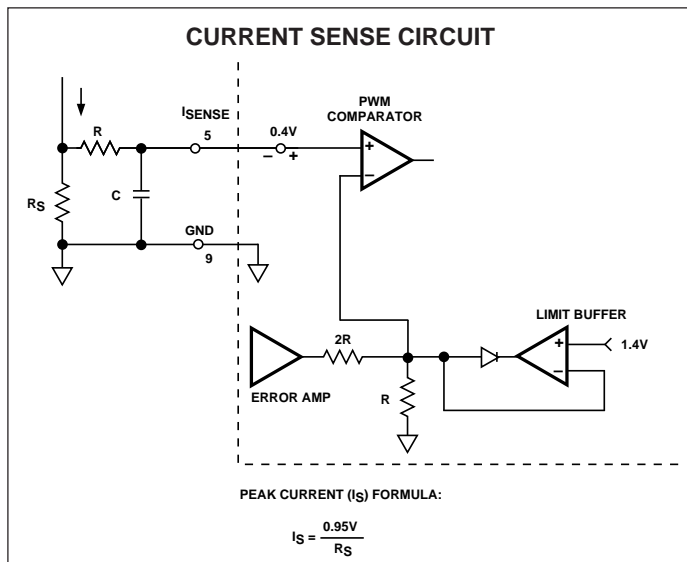

Current is sensed through voltage drop across resistor  $R_S$ . A small RC filter may be required to suppress switching transient. This voltage enters PWM Controller at  $I_{SENSE}$ , pin 5. A voltage of 0.4V is added before this is fed into PWM Comparator (+) input. The PWM Comparator (-) input senses the voltage feedback error amp output with a limit buffer that limits this voltage to 1.4V maximum. This limit buffer limits the peak current across  $R_S$  to a maximum of 0.95V. In normal operation, the error amplifier controls the current limit threshold.

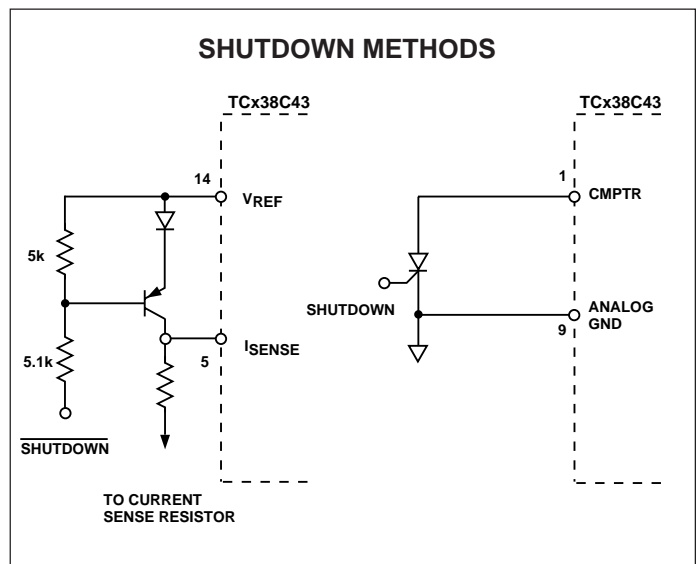

Shutdown can be accomplished by either pulling  $I_{SENSE}$  above 1 volt or pulling CMPTR, pin 1 to GND. This will set the PWM latch so that the output will remain low until the next clock pulse after the shutdown condition is removed.

## BENCH TEST OPERATIONAL SIMULATION

The timing ramp ( $R_T/C_T$ ) is buffered by the emitter fullpower and fed back to the  $I_{SENSE}$  input. This ramp simulates the  $di/dt$  current ramp which would flow through the primary of the transformer. The output voltage of the power supply is simulated by feeding some of the reference voltage into  $V_{FB}$ . The combination of the two levels determined the operating characteristics of the current mode controller.

TC18C43  
TC28C43  
TC38C43

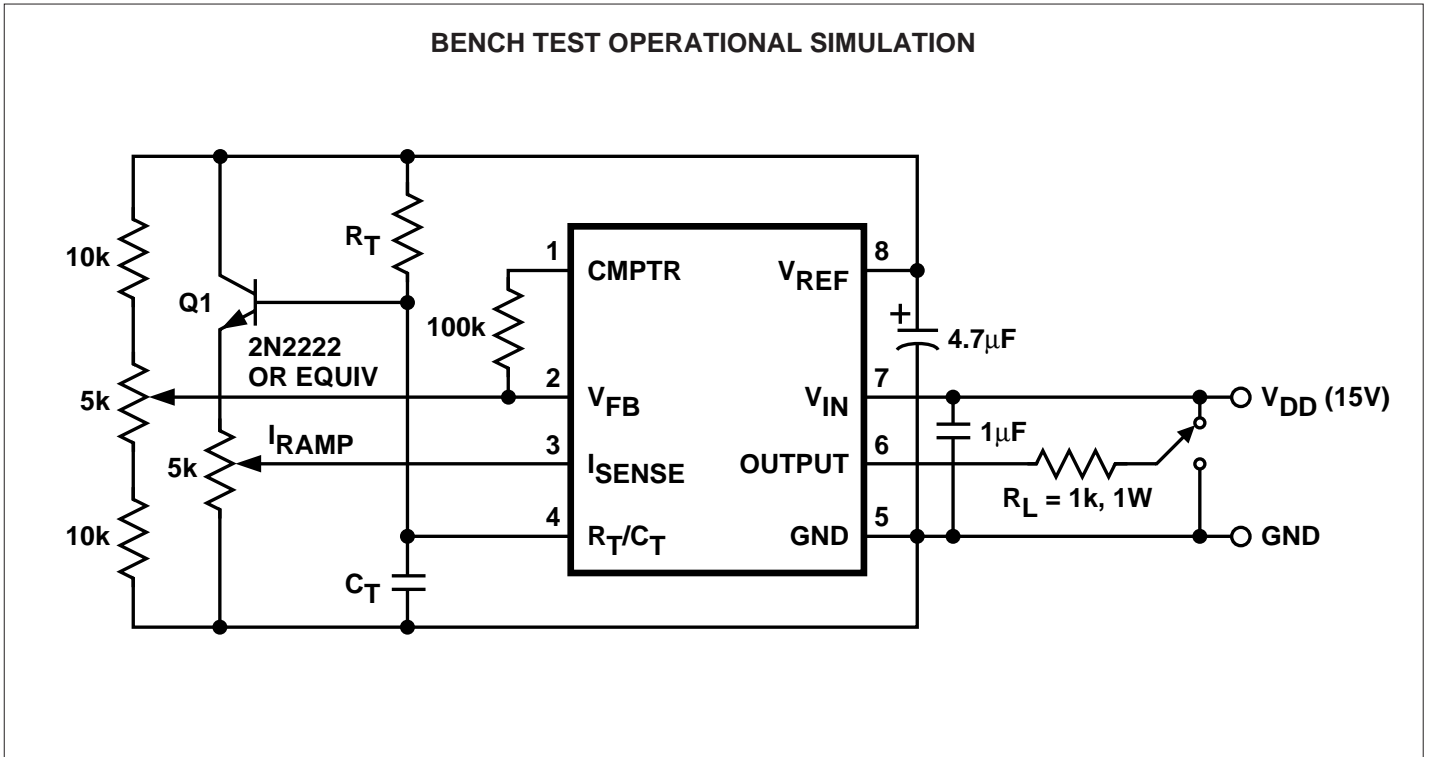

## TYPICAL CHARACTERISTICS

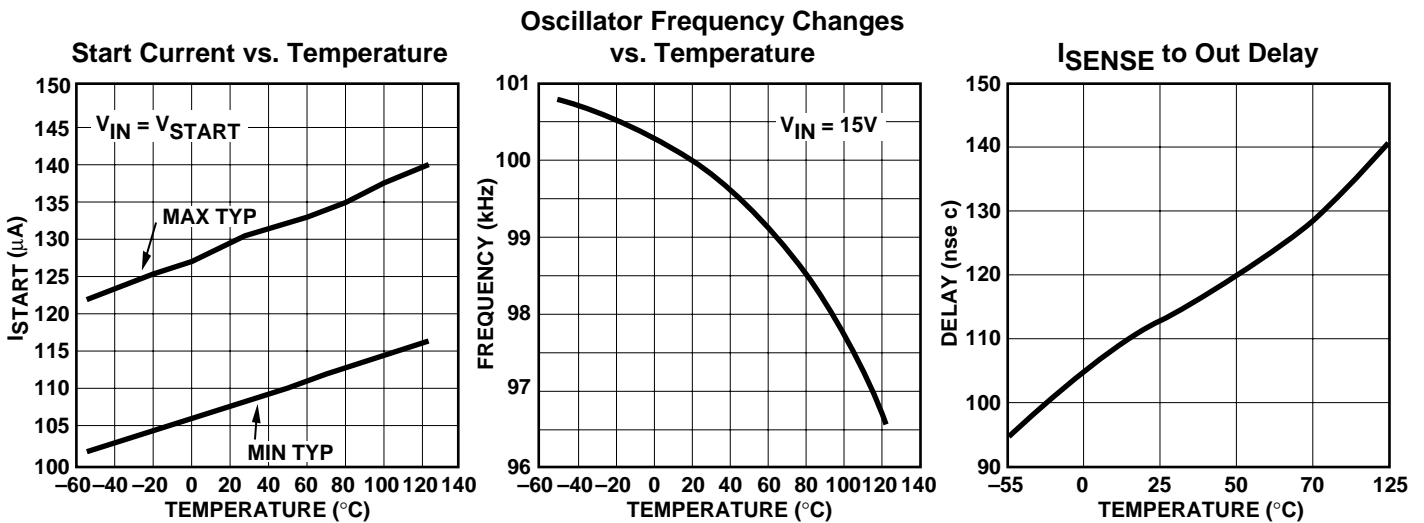

**TYPICAL CHARACTERISTICS (Cont.)**

