

The RF Line Microwave Pulse Power Transistors

MRF1004MB

**4.0 W, 960–1215 MHz
MICROWAVE POWER
TRANSISTORS
NPN SILICON**

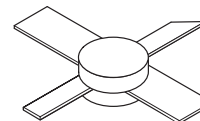

CASE 332A-03, STYLE 1

Designed for Class B and C common base amplifier applications in short and long pulse TACAN, IFF, DME, and radar transmitters.

- Guaranteed Performance @ 1090 MHz, 35 Vdc
Output Power = 4.0 Watts Peak
Minimum Gain = 10 dB
- 100% Tested for Load Mismatch at All Phase Angles with 10:1 VSWR
- Industry Standard Package
- Nitride Passivated
- Gold Metallized, Emitter Ballasted for Long Life and Resistance to Metal Migration
- Internal Input Matching for Broadband Operation

MAXIMUM RATINGS

Rating	Symbol	Value	Unit
Collector–Emitter Voltage	V_{CEO}	20	Vdc
Collector–Base Voltage	V_{CBO}	50	Vdc
Emitter–Base Voltage	V_{EBO}	3.5	Vdc
Collector Current — Continuous	I_C	250	mAdc
Total Device Dissipation @ $T_C = 25^\circ\text{C}$ (1) Derate above 25°C	P_D	7.0 40	Watts mW/ $^\circ\text{C}$
Storage Temperature Range	T_{stg}	-65 to +150	$^\circ\text{C}$

THERMAL CHARACTERISTICS

Characteristic	Symbol	Max	Unit
Thermal Resistance, Junction to Case (2)	$R_{\theta JC}$	25	$^\circ\text{C}/\text{W}$

ELECTRICAL CHARACTERISTICS ($T_C = 25^\circ\text{C}$ unless otherwise noted)

Characteristic	Symbol	Min	Typ	Max	Unit
----------------	--------	-----	-----	-----	------

OFF CHARACTERISTICS

Collector–Emitter Breakdown Voltage ($I_C = 5.0$ mAdc, $I_B = 0$)	$V_{(BR)CEO}$	20	—	—	Vdc
Collector–Emitter Breakdown Voltage ($I_C = 5.0$ mAdc, $V_{BE} = 0$)	$V_{(BR)CES}$	50	—	—	Vdc
Collector–Base Breakdown Voltage ($I_C = 5.0$ mAdc, $I_E = 0$)	$V_{(BR)CBO}$	50	—	—	Vdc
Emitter–Base Breakdown Voltage ($I_E = 1.0$ mAdc, $I_C = 0$)	$V_{(BR)EBO}$	3.5	—	—	Vdc
Collector Cutoff Current ($V_{CB} = 35$ Vdc, $I_E = 0$)	I_{CBO}	—	—	0.5	mAdc

ON CHARACTERISTICS

DC Current Gain ($I_C = 75$ mAdc, $V_{CE} = 5.0$ Vdc)	h_{FE}	10	—	100	—
---	----------	----	---	-----	---

NOTES:

(continued)

1. These devices are designed for RF operation. The total device dissipation rating applies only when the device is operated as RF amplifiers.
2. Thermal Resistance is determined under specified RF operating conditions by infrared measurement techniques.

ELECTRICAL CHARACTERISTICS — continued ($T_C = 25^\circ\text{C}$ unless otherwise noted)

Characteristic	Symbol	Min	Typ	Max	Unit
DYNAMIC CHARACTERISTICS					
Output Capacitance ($V_{CB} = 35\text{ Vdc}$, $I_E = 0$, $f = 1.0\text{ MHz}$)	C_{ob}	—	3.3	5.0	pF
FUNCTIONAL TESTS (Pulse Width = $10\ \mu\text{s}$, Duty Cycle = 1.0%)					
Common-Base Amplifier Power Gain ($V_{CC} = 35\text{ Vdc}$, $P_{out} = 4.0\text{ W pk}$, $f = 1090\text{ MHz}$)	G_{PB}	10	11	—	dB
Collector Efficiency ($V_{CC} = 35\text{ Vdc}$, $P_{out} = 4.0\text{ W pk}$, $f = 1090\text{ MHz}$)	η	40	45	—	dB
Load Mismatch ($V_{CC} = 35\text{ Vdc}$, $P_{out} = 4.0\text{ W pk}$, $f = 1090\text{ MHz}$, $VSWR = 10:1$ All Phase Angles)	ψ	No Degradation in Power Output			

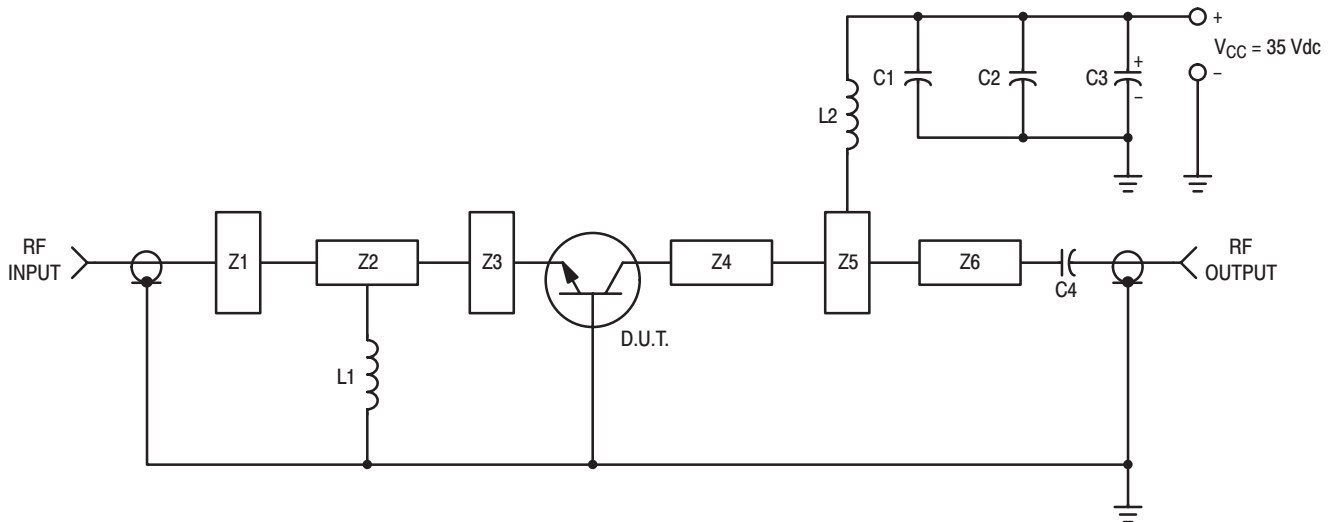

- C1 — $0.1\ \mu\text{F}$
- C2, C4 — 220 pF Chip Capacitor
- C3 — $20\ \mu\text{F}$, 50 V Electrolytic
- L1, L2 — 3 Turns #18 AWG, $1/8''$ ID
- Z1–Z6 Distributed Microstrip Elements, See Photomaster
- Board Material — $0.031''$ Thick Glass Teflon

Figure 1. 1090 MHz Test Circuit

TYPICAL CHARACTERISTICS

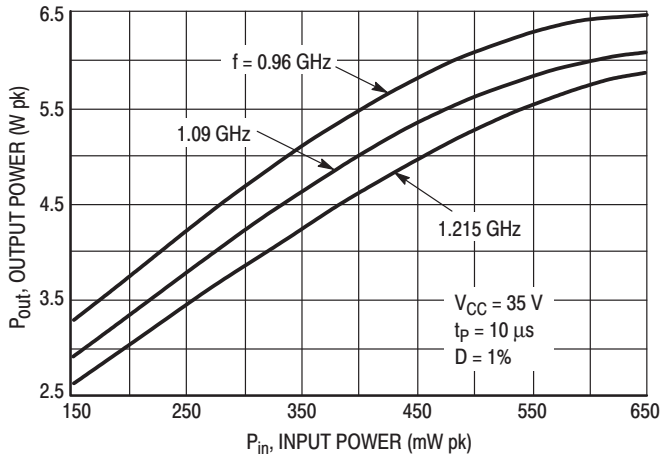

Figure 2. Output Power versus Input Power

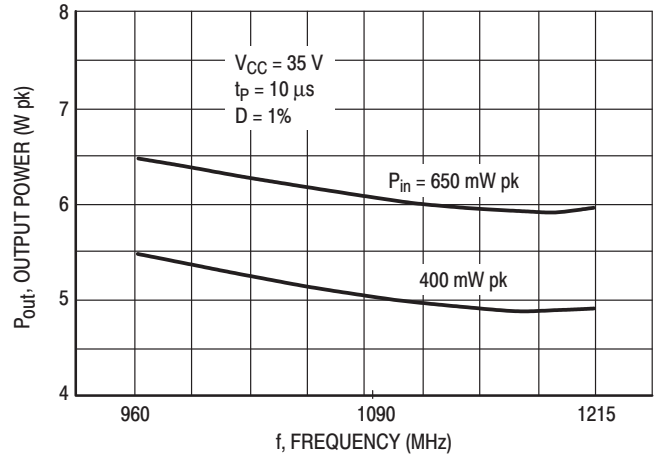

Figure 3. Output Power versus Frequency

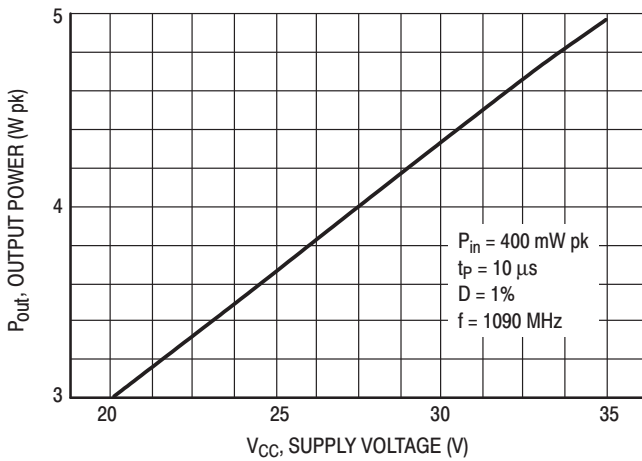

Figure 4. Output Power versus Supply Voltage

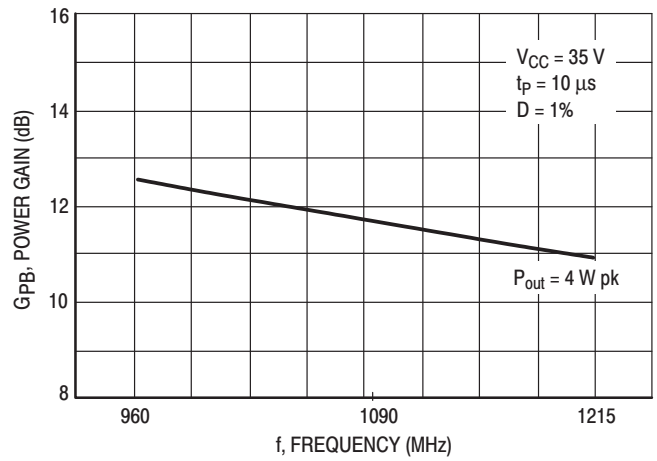
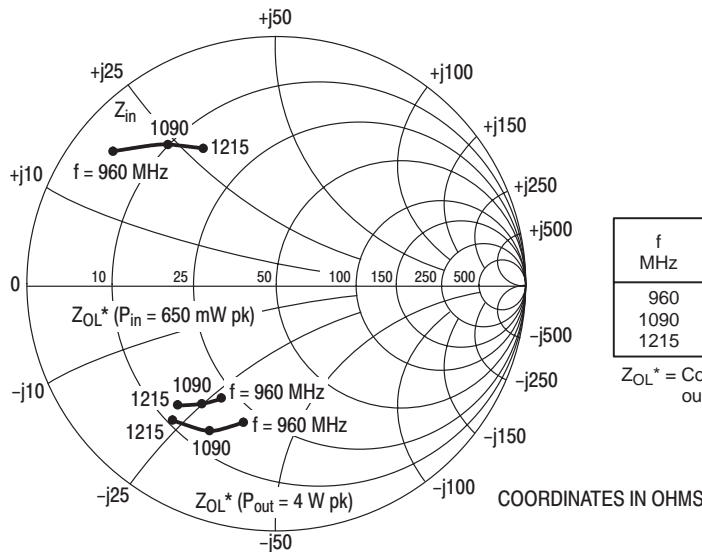

Figure 5. Power Gain versus Frequency



f MHz	Z _{in} Ohms	Z _{OL} * (P _{in} = 400 mW pk) Ohms	Z _{OL} * (P _{out} = 4.0 W pk) Ohms
960	5.0 + j17.5	23.5 - j26	22.5 - j36
1090	10 + j23	18.5 - j25	15 - j32.5
1215	16 + j29.5	15.5 - j23.5	11 - j23

Z_{OL}* = Conjugate of the optimum load impedance into which the device output operates at a given output power, voltage, and frequency.

Figure 6. Series Equivalent Input/Output Impedance

TYPICAL CHARACTERISTICS

$P_{out} = 4 \text{ W pk}$
 $V_{CC} = 35 \text{ V}$
 $t_p = 1 \text{ ms}$
 $D = 10\%$
 $f = 1090 \text{ MHz}$

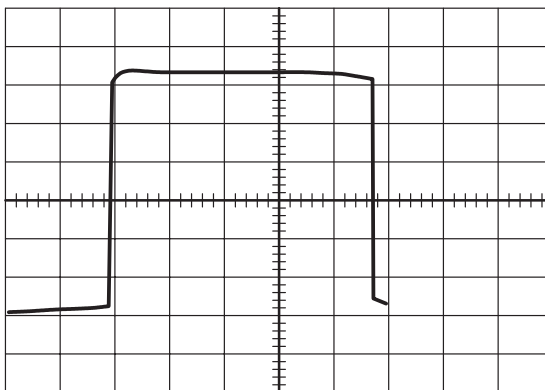
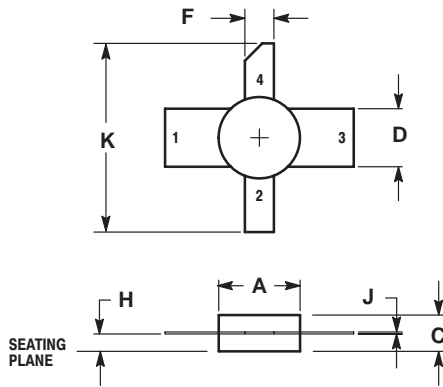

Figure 7. Typical Long Pulse Performance

PACKAGE DIMENSIONS



- NOTES:
 1. DIMENSIONING AND TOLERANCING PER ANSI Y14.5M, 1982.
 2. CONTROLLING DIMENSION: INCH.

DIM	INCHES		MILLIMETERS	
	MIN	MAX	MIN	MAX
A	0.270	0.290	6.86	7.36
C	0.115	0.135	2.93	3.42
D	0.195	0.205	4.96	5.20
F	0.095	0.105	2.42	2.66
H	0.050	0.070	1.27	1.77
J	0.003	0.007	0.08	0.17
K	0.600	---	15.24	---

- STYLE 1:
 PIN 1. BASE
 2. EMITTER
 3. BASE
 4. COLLECTOR

**CASE 332A-03
 ISSUE D**

Specifications subject to change without notice.

- **North America:** Tel. (800) 366-2266, Fax (800) 618-8883
- **Asia/Pacific:** Tel.+81-44-844-8296, Fax +81-44-844-8298
- **Europe:** Tel. +44 (1344) 869 595, Fax+44 (1344) 300 020

Visit www.macom.com for additional data sheets and product information.

REV 8

tyco / Electronics

MACOM