

## Description

The MK3230 is the smallest size, lowest power system clock synthesizer available. It is the ideal way to generate clocks for portable computers, PDAs, and other devices where low power is required. Using analog Phase-Locked Loop (PLL) techniques, the device operates from a single 32.768 kHz crystal to produce the 32.768kHz, CPU, system, keyboard controller, and floppy (or super I/O) controller output clocks.

The device has two power down modes. From the CPU decoding table (when FS0, FS1, and FS2 all are low), the CPU and 14.3 MHz system clocks can be turned off. Also, the keyboard and 24 MHz peripheral clocks can be shut off from  $\overline{\text{PD24+KBD}}$  (pin 10). The part has a separate VDD32 pin for the 32 kHz clock, allowing it to run at a different voltage (down to 2.0V) from the rest of the chip, allowing it to run from a back-up battery.

## Features

- Packaged in 16 pin narrow (0.150") SOIC 
- Input crystal frequency of 32.768 kHz
- Lowest power solution available
- Lowest profile clock solution where height is critical
- Output clock frequencies up to 80 MHz
- Five output clocks
- 3.3V or 5.0V operation
- Duty cycle of 45/55
- Seven selectable CPU frequencies
- CPU and peripheral clock power downs
- Separate battery supply pin for 32 kHz
- IDD less than 5μA when 32 kHz running
- Available with either 12MHz (-01) or 16MHz (-02) keyboard clock output
- 14.3MHz output is not suitable for driving PLL for CRT. Will drive all other functions
- 32kHz crystals require long startup (>500ms)

## Block Diagram

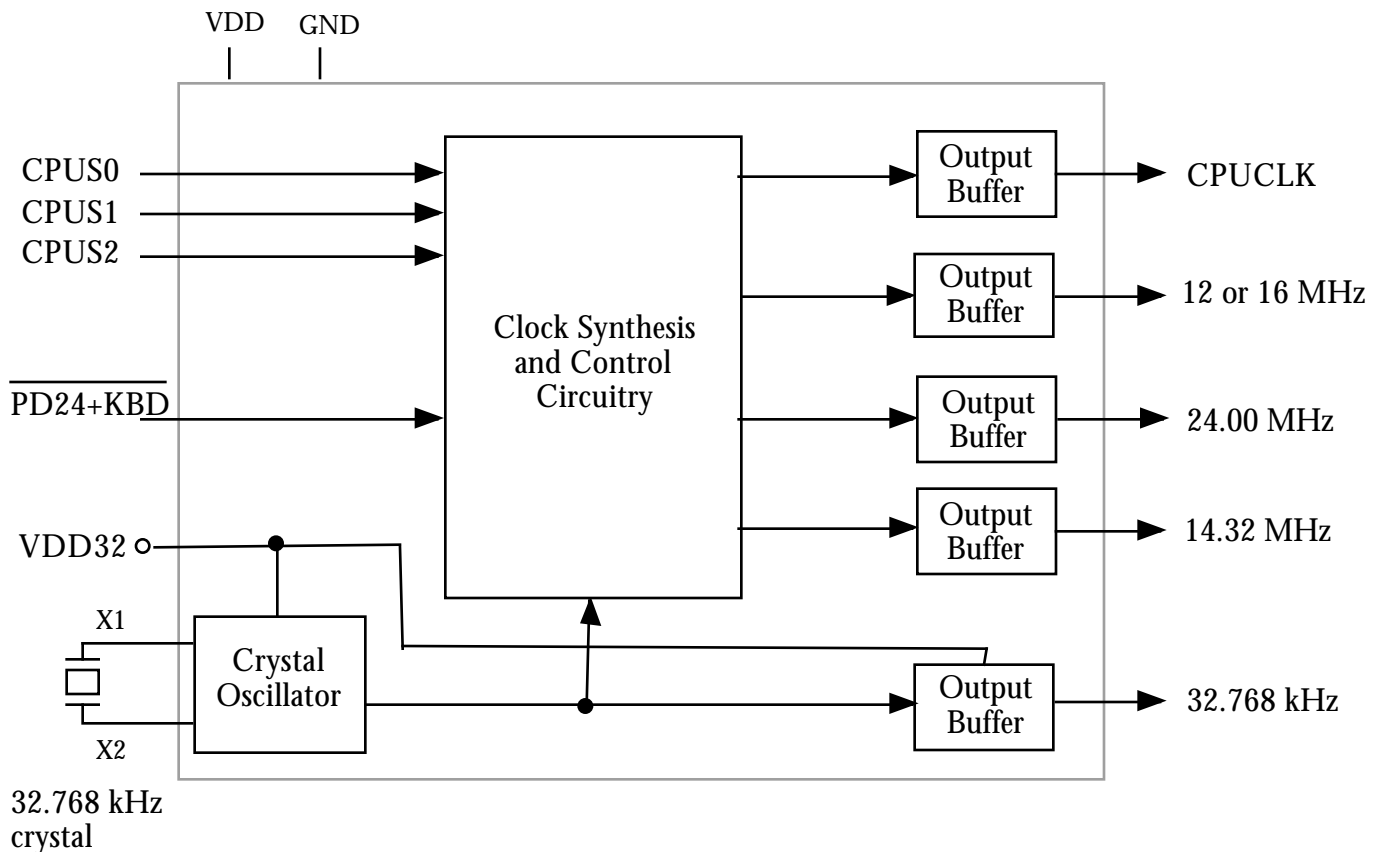



## Pin Assignment

CPUS2	1	16	CPUS1
X2	2	15	CPUS0
X1	3	14	CPUCLK
VDD32	4	13	VDD
VDD	5	12	GND
GND	6	11	14.3M
24M	7	10	PD24+KBD
32K	8	9	KBOUT

## CPU Clock Decoding

CPUS2	CPUS1	CPUS0	CPUCLK (MHz)
0	0	0	Off+14M off
0	0	1	80.00
0	1	0	25.00
0	1	1	66.66
1	0	0	20.00
1	0	1	50.00
1	1	0	33.33
1	1	1	4.00

Frequency transitions (except going to/from off) will occur smoothly, and are compatible with all 486 processors.

## Pin Descriptions

Number	Name	Type	Description
1	CPUS2	I	Select 2 for CPUCLK frequencies. See Table above.
2	X2	O	Crystal connection. Connect to 32.768 kHz crystal.
3	X1	I	Crystal connection. Connect to 32.768 kHz crystal.
4	VDD32	P	Separate power supply connection for 32.768kHz clock. Will operate to 2.0V.
5	VDD	P	Connect to +3.3V or +5V. Must be the same voltage as pin 13.
6	GND	P	Connect to ground.
7	24M	O	24 MHz floppy (or super I/O) clock output.
8	32K	O	32.768 kHz square wave clock output.
9	KBOUT	O	Keyboard clock output. Either 12MHz (-01) or 16MHz (-02)
10	PD24+KBD	I	Power Down 24M+keyboard. Shuts off both clock outputs (pins 7,9) when low.
11	14.3M	O	14.318 MHz system clock output. Do not drive a CRT PLL device with this output.
12	GND	P	Connect to ground.
13	VDD	P	Connect to +3.3V or +5V. Must be the same voltage as pin 5.
14	CPUCLK	O	CPUCLK output. See Table above.
15	CPUS0	I	Select 0 for CPUCLK frequencies. See Table above.
16	CPUS1	I	Select 1 for CPUCLK frequencies. See Table above.

Type: I = Input, O = output, P = power supply connection

Power Down status: Output clocks will stop in a low state when powered down

## External Components

The MK3230 requires a minimum number of external components for proper operation. Decoupling capacitors of 0.1 $\mu$ F should be connected between VDD and GND, and VDD32 and GND, as close to the MK3230 as possible. A 10k series resistor should be used to filter the VDD32 pin. A series termination resistor of 33 may be used for each clock output. The device does not require (nor do we recommend) capacitors connected to the crystal pins. The 32.768 kHz crystal must be connected as close to the chip as possible. See Application Brief MAB02 for a discussion on tuning for use on a real time clock (RTC).



## Electrical Specifications

Parameter	Conditions	Minimum	Typical	Maximum	Units
<b>ABSOLUTE MAXIMUM RATINGS (note 1)</b>					
Supply Voltage, VDD	Referenced to GND			7	V
Inputs and Clock Outputs	Referenced to GND	-0.5		VDD+0.5	V
Ambient Operating Temperature		0		70	°C
Soldering Temperature	Max of 30 seconds			260	°C
Storage Temperature		-65		150	°C
<b>DC CHARACTERISTICS</b>					
Operating Voltage, VDD		3.0		5.5	V
Operating Voltage, VDD32		2.0		5.5	V
Input High Voltage, VIH	VDD=5V	2.0			V
Input Low Voltage, VIL	VDD=5V			0.8	V
Output High Voltage, VOH	VDD=5V, IOH=-25mA	2.4			V
Output Low Voltage, VOL	VDD=5V, IOL=25mA			0.4	V
Input High Voltage, VIH	VDD=3.3V	1.9			V
Input Low Voltage, VIL	VDD=3.3V			0.4	V
Output High Voltage, VOH	VDD=3.3V, IOH=-8mA	2.4			V
Output Low Voltage, VOL	VDD=3.3V, IOL=8mA			0.4	V
IDD Operating Supply Current, 5V	No Load, 80MHz		25		mA
IDD32 with only 32 kHz running, 5V	No Load		3.5		µA
IDD Operating Supply Current, 3.3V	No Load, 80MHz		15		mA
IDD32 with only 32 kHz running, 3.3V	No Load		2.5		µA
Short Circuit Current, 5V	32 kHz output		±30		mA
Short Circuit Current, 5V	Each MHz output		±100		mA
Input Capacitance			7		pF
Internal Crystal Capacitance	Pins 2, 3 only		15		pF
<b>AC CHARACTERISTICS</b>					
Input Frequency			32.768		kHz
Output Clock Rise and Fall Time, 0.2 to 0.8VDD				2	ns
Output Clock Duty Cycle, all MHz clocks	At VDD/2	45	49 to 51	55	%
32.768 kHz Clock Duty Cycle	At VDD32/2		57		%
Absolute Clock Period Jitter, CPU clock	25 to 80 MHz	-500		500	ps
Power up time, CPU off to 80 MHz, 32k running	VDD=3.3 or 5V		9		ms
Transition time, 4 MHz to 80 MHz	VDD=3.3 or 5V		4		ms
Transition time, 80 MHz to 4 MHz	VDD=3.3 or 5V		2.5		ms
Power on time, VDD32=0V to all clocks stable	32.768kHz crystal with ESR 25k		500	750	ms

Note 1: Stresses beyond those listed under Absolute Maximum Ratings could cause permanent damage to the device. Prolonged exposure to levels above the operating limits but below the Absolute Maximums may affect device reliability.

**Note on the 14.32 MHz output :** The actual output frequency from this clock is 14.3196 MHz, versus 14.31818 MHz that has been traditional. This output can be used as the input to digital chips providing functions such as timing or keyboard, but it should NOT be used to drive a graphics PLL that is used for a CRT display. Instead, use a 14.318MHz crystal as the input to the CRT graphics device.



## Input and Output Voltages

The MK3230 can operate with  $V_{DD} = 3.0V$  to  $5.5V$ , and  $V_{DD32} = 2.0V$  to  $5.5V$  in any combination. Both  $V_{DD}$  pins (pin #5 and pin #13) must be connected to the same voltage.

The amplitude of the 32.768 kHz output clock will be equal to  $V_{DD32}$ , and the amplitude of the MHz clocks will be equal to  $V_{DD}$ .

If using a clock input, the input voltage applied to X1 may not exceed  $V_{DD32}$ , and the amplitude of any other input may not exceed  $V_{DD}$ . Consult MicroClock if your application is an exception to this.

## Package Outline and Package Dimensions

### 16 pin SOIC narrow

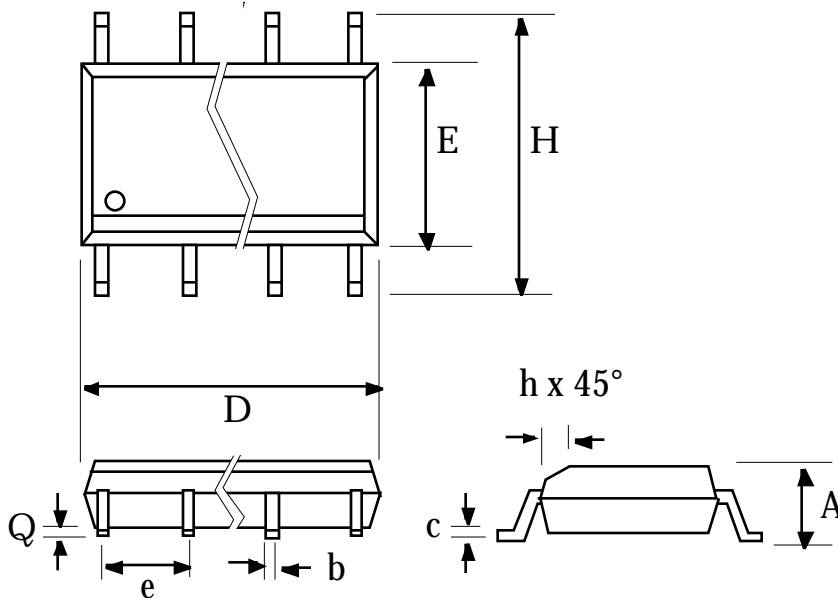

Symbol	Inches		Millimeters	
	Min	Max	Min	Max
A	0.055	0.070	1.397	1.778
b	0.013	0.019	0.330	0.483
c	0.007	0.010	0.191	0.254
D	0.385	0.400	9.779	10.160
E	0.150	0.160	3.810	4.064
H	0.225	0.245	5.715	6.223
e	.050 BSC		1.27 BSC	
h		0.016		0.406
Q	0.004	0.01	0.102	0.254

## Ordering Information

Part/Order Number	Marking	Keyboard frequency	Package	Temperature
MK3230-01S	MK3230-01S	12 MHz	16 pin SOIC	0-70°C
MK3230-02S	MK3230-02S	16 MHz	16 pin SOIC	0-70°C
MK3230-01STR	MK3230-01S	12 MHz	Add Tape & Reel	0-70°C
MK3230-02STR	MK3230-02S	16 MHz	Add Tape & Reel	0-70°C

While the information presented herein has been checked for both accuracy and reliability, MicroClock Incorporated assumes no responsibility for either its use or for the infringement of any patents or other rights of third parties, which would result from its use. No other circuits, patents, or licenses are implied. This product is intended for use in normal commercial applications. Any other applications such as those requiring extended temperature range, high reliability, or other extraordinary environmental requirements are not recommended without additional processing by MicroClock. MicroClock reserves the right to change any circuitry or specifications without notice. MicroClock does not authorize or warrant any MicroClock product for use in life support devices or critical medical instruments.